

HUGO GERNSBACK
Editor

SHORT WAVE CRAFT

February 1935

WORLD'S
LARGEST
SHORT WAVE
CIRCULATION

Record Your
Foreign Programs
See Page 586



25¢
BY CANADA
30¢

NRA
CODE

FREE

RADIO'S LEADING CATALOG



NEW AMPLIFIERS
A complete new listing of Sound Systems and amplifying units ranging from 3 1/2 to 50 watts. Includes new amplifiers with built-in relay mixers, new 3-channel mixers, new microphone amplifiers, etc.

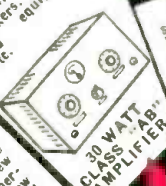

30 WATT CLASS AB AMPLIFIER

TEST EQUIPMENT
The 1935 ALLIED Catalog lists the complete new Supreme line of test instruments including the new Triplatt "Master" line—new storage and new capacitor, too. Includes the new "Supreme" line of test equipment. See the ALLIED Catalog.



HIGHEST QUALITY LOWER PRICES BETTER SERVICE

Send for this great book—over 100 value-packed pages devoted exclusively to radio.

NEW RECEIVERS
The 1935 ALLIED Catalog devotes two special sections to a great listing of new World-wide All-Wave, Dual Wave, Short Wave and Broadcast Receivers—Electric Battery, 32 Volt and Auto models, at new low prices.

BUILD YOUR OWN
More than 15 new Set-Building Kits are listed—covering All-Wave, Dual Wave, Short Wave, electric and battery models—Transceivers, etc. Also special Coil Kit and Diagram listing. We can supply all kits. Write for prices.

PUBLIC ADDRESS
An amazing Public Address array—absolutely different and superior in every detail. Special section lists complete Sound Systems and separate amplifier units for permanent, portable, mobile, rack and panel use, etc.

AMATEUR GEAR
A specialized Short Wave listing answers every need of the Amateur Set-builder, and Experimenter. New transmitting and receiving equipment—professional receivers, transceivers, antenna gear, all Short Wave parts.

SERVICE SUPPLIES
Page after page is presented exclusively for Radio Servicemen—showing thousands of standard quality radio replacement parts and accessories. Also the latest in test instruments at new low prices. You need this book.

SEND FOR

WORLD-WIDE RADIO
New powerful Radio Receivers—all with the latest Airplane Tubes and new Dual Purpose Antennas to go with these sets.



POPULAR NEW KITS
Build the famous All-Star All-Wave Superhet or the National 2-Tube Short Wave set—professional in looks and in operation—only two of the many fine new kits in the great 1935 ALLIED Catalog. Let Custom Set building bring you new prototypical Kits. better

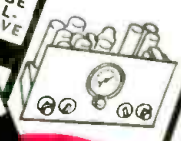

8 TUBE ALL-WAVE

S. W. HEADQUARTERS
The new ALLIED Catalog is packed with recent amateur developments. Including the new National "HRO," the new Hammarlund "Super Pro" and the Sensational Sky-ride Short Wave receiver. Also the famous Knight Meter 2-Way phones and Transceiver, "Acorn Type" tube, new antenna gear, etc. ALLIED Headquarters for all leading standard lines. Be sure to write for our

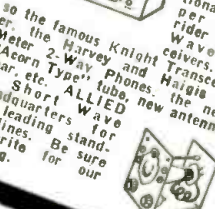

WRITE TODAY !

ALLIED RADIO CORPORATION
833 W. JACKSON BLVD., CHICAGO, Dept. E.

Please send me:
 THE 1935 ALLIED CATALOG.
 A complete Parts List for the circuit described in:

Name.....
Address.....
City..... State.....

Allied Radio CORPORATION
833 W. JACKSON BLVD., Chicago, Ill.

Read what happened



YES!

I'll take your training. That's what S. J. Ebert said. He has made good money and found success.

to these two men when I said:



NO!

I'm not interested. That's what this fellow said. Today he would be ashamed if I gave you his real name.

I will Train You at Home in Spare Time for a GOOD JOB IN RADIO

These two fellows had the same chance. Not long ago they each clipped and sent me a coupon, like the one in this ad. They got my book on Radio's opportunities.

S. J. Ebert, 49-B Quadrangle, University of Iowa, Iowa City, Iowa, saw that Radio offered him a real chance. He enrolled. The other fellow, whom we will call John Doe, wrote that he wasn't interested. One of those fellows who wants a better job, better pay, but never does anything about it. One of the many who spend their lives in a low-pay, no-future job, because they haven't the ambition, the determination, the action it takes to succeed.

Read what S. J. Ebert wrote me and remember that John Doe had the same chance: "Upon graduation I accepted a job as serviceman, and within three weeks was made Service Manager. This job paid me \$40 to \$50 a week compared with \$18 I earned in a shoe factory before. Eight months later I went with station KWCR as operator. From there I went to KTNT. Now I am Radio Engineer with WSUI. I certainly recommend the N.R.I. to all interested in the greatest field of all, Radio."

Get ready for Jobs like these. Many Radio Experts make \$40, \$60, \$75 a week

Spare time and full time set servicing; installing, operating, maintaining broadcast, avi-

FREE: Radio Servicing Tips

Let me PROVE that my Course is clear, easy to understand and fascinating to study. Send the coupon for a free lesson, "Trouble Shooting in D.C., A.C., and Battery Sets."

This interesting lesson gives 132 ways to correct common Radio troubles. I am willing to send this book to prove that you too can master Radio—just as thousands of other fellows have done. Many of them, without even a grammar school education, and no Radio or technical experience, have become Radio experts and now earn two or three times their former pay. Mail the coupon now.



"I want to help you. If you are earning less than \$35 a week I believe I can raise your pay. However, I will let you decide that. Let me show you what I have done for others, what I am prepared to do for you. Get my book, read it over, and decide one way or another." J. E. Smith.

ation, commercial, police, ship, and television stations. Good jobs with Radio dealers and jobbers. A service shop or Radio retail business of your own. I'll train you for these and other good jobs in connection with the manufacture, sale and service of Radio sending and receiving sets, auto sets, loud speaker systems, short wave sets, etc.

Save Money—Learn at Home. Money Back Agreement Protects You

Hold your job. I'll train you quickly and inexpensively right at home in your spare time to be a Radio Expert. You don't need a high school or college education. My 50-50 method of training—half with lessons, half with Radio equipment—gives you broad practical ex-

perience—makes learning at home easy, fascinating, practical. I will agree in writing to refund your money if you are not satisfied with my Lesson and Instruction Service when you finish.

Earn \$5, \$10, \$15 a Week in Spare Time

That's what many of my students do soon after enrolling. I'll give you special training, plans and ideas to help you do it. Many students have made \$200 to \$1,000 in spare time while learning. Nearly every neighborhood offers a spare time serviceman an opportunity to make good money. I'll show you how to "cash in"—show you why my Course is World-Famous as "the Course that pays for itself."

Find Out What Radio Offers You

Mail the coupon. My book is free to any ambitious fellow over fifteen years of age. It tells you about Radio's spare time and full time job opportunities—about my Course, what I give you, what my students and graduates do and make. There is no obligation. Act today. Mail coupon in an envelope or paste on a 1c postal card. Do it right now.

J. E. SMITH, President
National Radio Institute, Dept. 5BB3
Washington, D. C.



FOR FREE BOOK OF FACTS ABOUT RADIO

J. E. SMITH, President
National Radio Institute, Dept. 5BB3, Washington, D. C.

Dear Mr. Smith: I want to take advantage of your Special Offer. Send me your two books, "Trouble Shooting in D.C., A.C., and Battery Sets" and "Rich Rewards in Radio." I understand this does not obligate me. (Please print plainly.)

Name Age

Address

City State M

Please mention SHORT WAVE CRAFT when writing advertisers

IN THIS ISSUE: PROMINENT SHORT-WAVE AUTHORS

Bryant . Schrage . Short . Lurie . Shuart . Gernsback

HUGO GERNSBACK
Editor



H. WINFIELD SECOR
Managing Editor

GEORGE W. SHUART,
W2AMN
Associate Editor

Contents For February, 1935

Editorial—"Multiple Reception," by Hugo Gernsback....	581
"Calling All Cars" on 10 Meters!.....	582
Short Waves Link Rotarians of Two Americas.....	583
5-Meter Station Atop Hotel New Yorker, by Eli Lurie, Chief Radio Engineer, Hotel New Yorker.....	584
Blind To Learn Radio with Braille Diagrams.....	585
Record Your "Foreign" Programs, by M. Harvey Gernsback	586
Economy 3—A Short Wave Set for the Fan or Ham, by George W. Shuart, W2AMN.....	588
"3 Tubes Equal 6" in this Superhet, by M. Harvey Gernsback	590
World-Wide Short-Wave Review, edited by C. W. Palmer	592
SHORT WAVE SCOUT "News".....	594
SHORT WAVE SCOUTS—12th Trophy Winner.....	595
Short Waves and Long Raves—Our Readers' Forum....	596
Tin-Can 4-Tube Set, by Elwyn S. Bryant, E.E.....	598
5-Meter Mobile Xmitter, by George W. Shuart, W2AMN	599
What's New in Short Wave Apparatus.....	600
16-Tube Set Has Range from 9 to 2400 Meters.....	600
A 13 to 200 Meter Short-Wave Converter.....	601
\$5.00 For Best Short Wave "Kink".....	604
SHORT WAVE STATIONS OF THE WORLD, Com- plete list, including "Police" and "Television" sta- tions, edited by M. Harvey Gernsback.....	605
When to Listen In.....	608
SHORT WAVE LEAGUE—"Code Test" Below 6 Meters Must Go!	609
Short Wave "Question Box," edited by W2AMN.....	610
HIGH FIDELITY—How To Get It on your Old Set, by Wilhelm Schrage	612

Features in the March Issue

- A 1-tube "A.C." short-wave receiver, by Art Gregor.
- Up-To-Date "BEGINNERS" Transmitter—No. 1 of a series
—Rack and Panel 'n-Everything, by George W. Shuart,
W2AMN.
- How to use two 800's with "Long Lines."
- A 10-Tube Short-Wave Superhet.
- A "Free-Wheeling" Receiver.
- The "Regenadyne 5," a smooth-tuning receiver, by W. R.
Humphries.
- BS-4 Works Loud Speaker—Has Band Spread Tuning, by
Albert Friese, Jr.



Certified Circuits

● **SHORT WAVE CRAFT** goes to a large expense in verifying new circuits. When you see this seal it is your guarantee that such sets have been tested in our laboratories, as well as privately, in different parts of

the country. Only "Constructional-Experimental" circuits are certified by us.

When you see our certified seal on any set described, you need not hesitate to spend money for parts, because you are assured in advance that the set and circuit are bona fide and that this magazine stands behind them.

SHORT WAVE CRAFT is the only magazine that certifies circuits and sets.

OUR COVER

● A great wave of popular interest in recording short-wave programs is sweeping over the country, as hundreds of inquiries received from our readers indicates. Listeners are anxious to record many of the interesting "foreign," as well as local short-wave programs. M. Harvey Gernsback, who has carried out many interesting experiments in this direction, tells you how to go about it on page 586.

COPYRIGHT, 1935, BY H. GERNSBACK

Published by **POPULAR BOOK CORPORATION**

HUGO GERNSBACK, President - - - H. W. SECOR, Vice-President
EMIL GROSSMAN - - - - - Director of Advertising
Chicago Adv. Office - - - - - L. F. McCLURE, 919 No. Michigan Ave.
Publication Office - - - - - 404 N. Wesley Avenue, Mount Morris, Ill.
Editorial and General Offices - - - 99-101 Hudson St., New York, N. Y.
London Agent: HACHETTE & CIE., 16-17 King William St., Charing
Cross, W.C.2
Paris Agent: HACHETTE & CIE., 111 Rue Reaumur
Australian Agents: MCGILL'S AGENCY, 179 Elizabeth St., Melbourne

SHORT-WAVE CRAFT—Monthly. Entered as second class matter May 7, 1930, at the post office at Mount Morris, Illinois, under the act of March 3, 1879. Trademarks and copyrights by permission of H. Gernsback, 99-101 Hudson St., N. Y. C. Text and illustrations of this magazine are copyrighted and must not be reproduced without permission. **SHORT WAVE CRAFT** is published on the 1st of every month. Twelve numbers per year. Subscription price is \$2.50 a year in the United States and possessions. Canada and foreign countries, \$3.00 a year. Single copies 25c. Address all contributions for publication to Editor, **SHORT WAVE CRAFT**, 99-101 Hudson St., New York, N. Y. Publishers are not responsible for lost manuscripts. Contributions cannot be returned unless authors remit full postage. **SHORT WAVE CRAFT** is for sale at all principal newsstands in the United States and Canada. European agents: Brentano's, London and Paris. Printed in U. S. A. Make all subscription checks payable to Popular Book Corporation.

OPPORTUNITIES *are many* for the Radio Trained Man

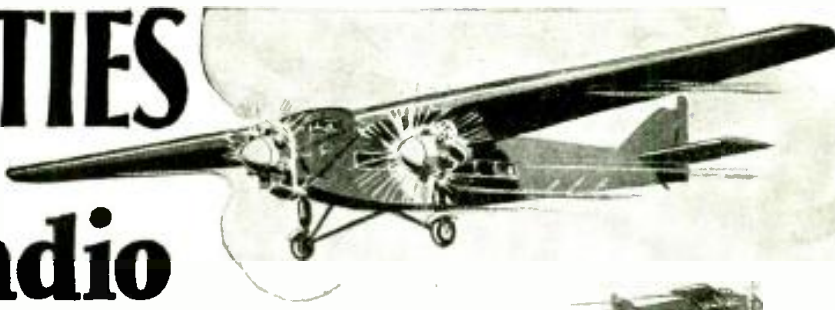

Don't be an untrained man. Let me show you how to get your start in Radio—the fastest growing, livest money-making game on earth.

Jobs Leading to Salaries of \$35 a Week and Up

Prepare for jobs as Designer, Inspector and Tester—as Radio Salesman and in Service and Installation Work—or for work in a Broadcasting Station—as Wireless Operator on a Ship or Airplane, or in Talking Picture or Sound Work—HUNDREDS OF OPPORTUNITIES for a real future in Radio!

Ten Weeks of Shop Training Pay Your Tuition After Graduation

We don't teach by book study. We train you on a great outlay of Radio, Television and Sound equipment—on scores of modern Radio Receivers, huge Broadcasting equipment, Television apparatus, Talking Picture and Sound Reproduction equipment, Code Practice equipment, etc. You don't need advanced education or previous experience. We give you—RIGHT HERE IN THE COYNE SHOPS—the actual practice and experience you'll need for your start in this great field. And because we cut out all useless theory and only give that which is necessary you get a practical training in 10 weeks.

TELEVISION *and* TALKING PICTURES

And Television is already here! Soon there'll be a demand for THOUSANDS of TELEVISION EXPERTS! The man who learns Television now can have a great future in this great new field. Get in on the ground-floor of this amazing new Radio development! Come to COYNE and learn Television as it should be learned on Television equipment. Talking Picture and Public Address Systems offer opportunities to the Trained Radio Man. Here is a great new Radio field just beginning to grow! Prepare NOW for these wonderful opportunities! Learn Radio Sound Work at COYNE on actual Talking Picture and Sound Reproduction equipment.

PAY FOR YOUR TRAINING After You Graduate

I am making an offer that no other school has dared to do. I'll take you here in my shops and give you this training and you pay your tuition after you have graduated. 60 days' after your 12 weeks' training period, start paying me back—then you have over a year to complete your payments. There are no strings to this offer. I know a lot of honest fellows haven't got a lot of money these days, but still want to prepare themselves for a real job so they won't have to worry about hard times or lay offs.

I've got enough confidence in these fellows and in my methods to give them the training they need and let them pay me back after they have completed their training.

ELECTRIC REFRIGERATION AIR CONDITIONING

To assure your thorough preparation for a prosperous future, I include—at no extra cost—a course in Electric Refrigeration and Air Conditioning, taught by personal instruction and actual work on latest-type equipment.

ALL PRACTICAL WORK At COYNE in Chicago

ALL ACTUAL, PRACTICAL WORK. You build radio sets, install and service them. You actually operate great Broadcasting equipment. You construct Television Receiving Sets and actually transmit your own Television programs over our Television equip-

ment. You work on real Talking Picture machines and Sound equipment. You learn Wireless Operating on Actual Code Practice apparatus. We don't waste time on useless theory. We give you the practical training you'll need—in 10 short, pleasant weeks.

MANY EARN WHILE LEARNING

You get Free Employment Service for Life. And don't let lack of money stop you—my plan makes it possible to get Coyne training with very little money. Many of our students make all or a good part of their living expenses while going to school and if you should need this help just write to me. Coyne is 35 years old. Coyne Training is tested—proved beyond all doubt. You can find out everything absolutely free. Just mail coupon for my big free book!

H. C. Lewis, Pres. RADIO DIVISION Founded 1899

Coyne Electrical School

500 S. Paulina St., Dept. 25-2K, Chicago, Ill.

Mail Coupon Today for All the Facts

H. C. LEWIS, President

Radio Division, Coyne Electrical School

500 S. Paulina St., Dept. 25-2K, Chicago, Ill.

Dear Mr. Lewis:—Send me your Big Free Radio Book, and all details of your Special Offer, including Electric Refrigeration, Air Conditioning courses and your "Pay After Graduation" offer.

Name _____

Address _____

City _____ State _____

Please mention SHORT WAVE CRAFT when writing advertisers

WORLD GLOBES

FOR SHORT WAVE ENTHUSIASTS

NOW AT LOW PRICES

THESE remarkable globes, executed in fourteen colors, are absolutely indispensable for short wave fans. Notable among the numerous features of these world globes, is that a damp cloth quickly removes all dust and water does not harm the surface.

Short Wave fans are enabled to determine correct time in various centers of the world with the aid of these maps; distances from city to city can be accurately established.

There is a graduated "Meridian" scale of black enameled metal with the 9" and 12" globes. An additional feature is the movable hour scale found at the north pole—this facilitates determining the hour in any part of the world.

Only on a globe of this size is it possible to get an accurate picture of countries and their relative positions to each other. You will actually be amazed when you compare distances—from New York to Moscow; from Cape Town to Tokio; from Los Angeles to Rio de Janeiro, etc. A flat map is deceptive for measuring, but take a small string and stretch it across the globe, from city to city, and you have the correct distances.

Here are globes that add dignity to home, office, studio or laboratory—a globe that everyone would be proud to possess.

Each world globe contains a listing of over 7,500 cities in nations the world over—spellings conform to international geographic standards—all globes are of 1934 production. GET ONE OF THESE FINE WORLD GLOBES TODAY!



World Globe No. 147

12" Globe. New model—equipped with wooden floor stand finished in walnut. Height overall 35". Globe constructed with half meridian. New World Globe Handbook included FREE. A marvelous buy. Never has a floor model Globe been sold at such a low price. Shipping weight 9 lbs.

PRICE \$4.15

F.O.B. Chicago.

World Globe No. 99

9" Globe, equipped with sturdy, black metal base and full meridian. Same ball as our No. 139 but reduced 1/4 in size and scale. Included with globe is newly printed World Globe Handbook FREE. Shipping weight 6 lbs.

PRICE \$2.05

F.O.B. Chicago.



No. 99

World Globe No. 47

7" Globe, equipped with sturdy metal base and half meridian. Index to countries of the world by latitude and longitude shown on base. Shipping weight 2 lbs.

PRICE \$0.90

F.O.B. Chicago.



No. 47



No. 147

Gentlemen:
I received the World Globe and am certainly well pleased with its completeness, appearance and its usefulness. Short wave listening has become a hobby with me, and this World Globe is a necessary accessory to any short wave listener or, for that matter, to any home.
P. C. ELLIS, Supt.
Laboratory—19th and Campbell Streets, Kansas City, Mo.

SPECIAL THIS MONTH ONLY

World Globe No. 139

12" Globe, equipped with sturdy, black metal base and half meridian. Contains over 7,500 names and cities. Spellings conform to authoritative world standards. Hundreds sold to many short wave fans during the last year. Copy of World Globe Handbook included FREE. Shipping weight 8 lbs. **PRICE**

\$2.95

F.O.B. Chicago.



No. 139

All globes are carefully packed in original cartons assuring safe delivery. **ORDER BY NUMBER.** Send check or money order, plus sufficient postage for delivery by parcel post. Globes are shipped from our Chicago warehouse. Register letter if it contains cash, or currency or stamps. If preferred, specify that shipment be sent express collect. **ALL ORDERS ARE FILLED PROMPTLY.**

ALL GLOBES SHIPPED IMMEDIATELY

ORDER YOUR GLOBE TODAY!

SHORT WAVE CRAFT SWC-2-35

59 Hudson Street, New York, N. Y.

Gentlemen: Enclosed you will find my remittance of \$..... for which please ship me the following World Globe.

- World Globe No. 99 @ \$2.05
- World Globe No. 147 @ \$4.15
- World Globe No. 47 @ \$0.90
- World Globe No. 139 @ \$2.95

Name

Address

City State

Send remittance in check or money order—register letter if it contains cash, stamps or currency. **GLOBES ARE SHIPPED FROM OUR WAREHOUSE IN CHICAGO—F. O. B. FROM THAT CITY.**

SHORT WAVE CRAFT 99 HUDSON STREET, NEW YORK, N. Y.

Please mention SHORT WAVE CRAFT when writing advertisers



"Multiple Reception"

An Editorial By HUGO GERNSBACK

● IF YOU have a short-wave set, and most of my readers undoubtedly have, you will have noticed, whether your set is a 2-tube or even a 10-tube one, that reception at the present time is frequently hampered by *fading*. This problem short-wave technique still has to solve.

A similar situation prevailed in the broadcasting field many years ago, before the broadcast stations had the high power which they now employ. Thus, listeners a hundred or 200 miles and even less distant from a broadcast station experienced the annoying fading phenomenon. Since the various stations have increased their power, this fading phenomenon has been largely overcome and is now not so much felt except for stations more than 500 miles distant.

In short waves, we are still hampered with this fading situation, and this condition will probably prevail for some years to come. While some of the short-wave stations are doubling and tripling their power right along,—which helps considerably,—still on poor days fading is still with us, and no matter how many tubes we have, reception is apt to be poor at times. Very often too, the *noise level* is much stronger than the *signal intensity* and then we get nothing but noise.

Many short-wave experimenters for this reason have frequently had recourse to a technique which, for want of a better name, I term "multiple reception." Multiple reception falls into two classes, (1) a multiple aerial switching arrangement and (2) a multiplicity of sets operated simultaneously.

It is well known that if we have a single aerial pointing *away* from the station to which you are listening, the reception will be at *maximum* in this case. If you point the aerial directly *toward* the station from which the signal comes, reception is at its *lowest*. It is also not quite as good at right angles. It follows from this that if you have an aerial pointing away from Europe, for instance, that European stations will come in better, while stations from the west, on this same aerial, will come in worse. To clear the situation, many experimenters are using four distinct aerial systems, all pointing in different directions. Then, by means of a switching arrangement, any aerial can be instantaneously connected to the set and surprising results are thus achieved. Very frequently, when fading is bad, and the noise level high, by using all four aeriels simultaneously, connected as one aerial, a badly fading signal can be enormously increased and reception made enjoyable. Furthermore, when stations interfere with each other, by selecting a different aerial better results can be had. For instance, if the European directive aerial interferes with the signal from South America, the European signal can be reduced by disconnecting that aerial and using the *north-south* aerial instead.

Several experimenters have gotten astonishing results with such a system, and have become so adept at handling the switching arrangement, that they can almost instantly

correct a bad situation and keep the signal on the loudspeaker. We all know what it means to listen to a distant program and just when the announcer is ready to give the call letters to have that station fade out. The multiple aerial arrangement corrects this situation to a nicety, and I highly recommend it until such time where the short-wave art is advanced sufficiently that this arrangement is no longer necessary.

It should be noted in passing that this same arrangement is used by the commercial companies in selecting different aeriels for different times of the day and switching from one to another for better results. It is common radio engineering practice today. Thus, for instance, Columbia Broadcasting System, which re-broadcasts signals from the Byrd Antarctic Expedition, does not rely upon a single aerial or path but uses a multiplicity of channels, as follows: Little America (L.A.) direct to Riverhead; L.A. to Buenos Aires, S.A. to Riverhead; L.A. to Honolulu, to San Francisco, to Riverhead or N.Y. City; L.A. to San Francisco, to N.Y. City.

This brings us to the second alternative of *multiple reception*, i.e., by using a multiplicity of radio receivers. The best way to do this, if you can afford it, is to have two or more sets all in the same room, all operating independently from independent aeriels. A number of sets, particularly of the multi-tube variety, such as 8- or 10-tube sets, work exceedingly well on short waves, with only a few feet of aerial wire. By using such a set, the noise-level is cut down a good deal, because "man-made" static in the neighborhood does not raise as much havoc with a short aerial as with a longer one, which picks up more noise. For demonstration purposes, and whenever it becomes necessary to listen to a particular station that is hard to get and difficult to "hold", a multiple set arrangement is always wise, because with this instrumentality you will be able to catch many calls that you could not get otherwise. It will be found that by having the sets connected to different aeriels that very frequently one set will deliver a signal clear when the other set will not, but by keeping all of them running simultaneously, it is often possible to thus pull in the elusive calls that you might never get otherwise.

One thing is of importance in connection with this arrangement and that is, that the set must not be in an *oscillating* condition! If it is above the oscillating point, the sets will interfere with each other and all you will get is "howls" on all of them. By keeping just below the oscillating point this condition will rectify itself automatically. Not only will the receivers not interfere with each other, but they will not interfere with your neighbors' sets, a thing that many experimenters frequently run into.

We know one experimenter in New York who has no less than five sets which he operates simultaneously, and he gets astonishing results, even on "off" nights when reception is admittedly poor for other listeners.

SHORT WAVE CRAFT IS PUBLISHED ON THE 1st OF EVERY MONTH

This is the February, 1935, Issue—Vol. V, No. 10. The Next Issue Comes Out February 1

Editorial and Advertising Offices, 99-101 Hudson Street, New York City

"Calling All Cars" ON 10 METERS!

● A complete 10-meter Police Radio installation recently completed in the city of Newark, N. J. The novel antenna system is fully described.



Center photo, left—Unique concentric transmission line, composed of two copper tubes, one inside the other, being run into the base of the 100-foot steel flag-pole atop the building. Transmission line runs up inside pole, "topped" by a tapered brass tube 22 feet high, 15 feet of which serves as the "actual" antenna, 600 feet above the street. Below—making tuning adjustment on the 10-meter transmitter.



Top photo, left, shows engineers making test of 10-meter antenna system before being hoisted to the top of the steel flagpole. The inner tube of the transmission line parallels the brass tube for seven feet; the remaining 15 feet of the brass tube serves as the "actual" antenna, 600 feet above street level. Lower photo, left, shows new tube being inserted in rear of 10-meter transmitter.

Photos courtesy Western Electric Company.

10 Meter Waves "Static Free"

Operation on an ultra-high frequency, as embodied in the Newark system, possesses certain advantages for municipal stations. Freedom from atmospheric disturbance is one. Newark motor patrolmen listening to their receivers will not be troubled by static, thunder-storms or other types of interference which are ordinarily picked up by receivers in the medium frequency bands.

As the wave length to be used determines the length of the antenna, the extremely short waves used in the ultra-high frequency system mean proportionately shorter antennas. In the Newark system a short upper section of the 100-foot flagpole on the National Newark & Essex Bank Building serves as a very efficient antenna. To operate in the medium wave a longer antenna is necessary. The shortness of the antenna makes possible construction of transmitters which are mobile. Should Newark authorities at any time decide to establish two-way radio service, transmitters could be installed in police cars thus enabling the motor patrolman to talk to headquarters as well as receive.

Features of 10 Meter System

Ultra-high frequency waves have characteristics which prevent their being picked up over as great distances

as can longer waves and consequently broadcasts made over ultra-high frequency systems confine themselves to smaller areas. A city as near as Albany, for instance, could probably use the same frequency as Newark without overlapping.

In adopting this system, the City of Newark is taking a leading part in opening up the new sector of radio channels for police work throughout the United States. The medium frequency bands assigned for police work extend roughly from 1,600 to 1,700 kilocycles and from 2,300 to 2,500 kilocycles. These comparatively narrow bands are in many parts of the country completely occupied with police assignments. The ultra-high frequency band ranging from 30,000 to 42,000 kilocycles embraces a range of 12,000 kilocycles within which a far greater number of police assignments may be made. The separation between ultra-high frequency channels, however, is

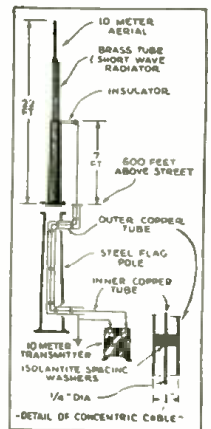

● THE tip of a flagpole serving as an antenna, hollow wires which, like water pipes, carry electricity without leaking, a quartz crystal scarcely thicker than a hair which acts as a control by vibrating 5,000,000 times a second, and operation in a wave band so remote from atmospheric disturbance that a bolt of lightning would cause only a barely audible click, are among the features of the radio system which has just been placed in operation by the Police Department of the City of Newark.

The system operates on 30,100 kilocycles (9.97 meters) an ultra-high frequency being within a new frequency band tentatively assigned for police radio work by the Federal Communications Commission. This frequency is about 20 times higher than the medium frequency band regularly assigned for police work and which is used by most police radio systems now in operation. So popular has radio proved for police service that in certain sections of the country few channels in the medium frequency band remain unassigned. Hence the Commission's decision to open up new frequencies for this service.

(Continued on page 613)

S-W's Link Rotarians of 2 Americas

ANOTHER milestone was passed in the now rapid progress of short-wave radio toward greater public popularity and service when, on Nov. 15, probably the largest audience ever assembled to hear a two-way Pan-American broadcast, tuned in on a joint radio meeting of Rotary clubs in Buenos Aires, Argentina, S.A., and Schenectady, N.Y.

Notified by Rotary International, every club in North and South America was invited to hold simultaneous meetings and asked to prepare for the event by installing two all-wave receivers—one tuned to General Electric's short-wave station W2XAF at Schenectady and the other to Transradio International's station LSX at Buenos Aires. Since both stations have been consistently and clearly heard, during good atmospheric conditions, in every part of the western hemisphere, this plan made it possible for 125,000 Rotarians of some 3000 clubs in the two Americas to attend the joint Schenectady-Buenos Aires ceremonies via short waves.

The inter-American program, beginning at 9:00 p.m. in Schenectady, presented a number of notables in Rotary's international organization. President Emeritus Paul P. Harris of Chicago, founder of Rotary, and Walter W. Head, vice president of Rotary International expressed the opinion that the unique interclub meeting exemplified the sixth object of Rotary—promotion of international fellowship. Official greetings from the United States were extended by Secretary of Commerce Daniel C. Roper, speaking from Washington by remote control. From Buenos Aires, official greetings, in exchange, were sent to North America by Senor Luis Duhau, Argentina's minister of agriculture, and an expression of good wishes from the Buenos Aires club was made by President Ceballos of that unit.

The program was staged by a committee of the Schenectady Rotary club acting in cooperation with the General Electric Company, which placed the facilities of W2XAF at the Rotarians' service and arranged the two-way contact with Transradio International's LSX. To facilitate reception throughout the country, an arrangement was made whereby radio dealers cooperated with their local Rotary clubs by offer-

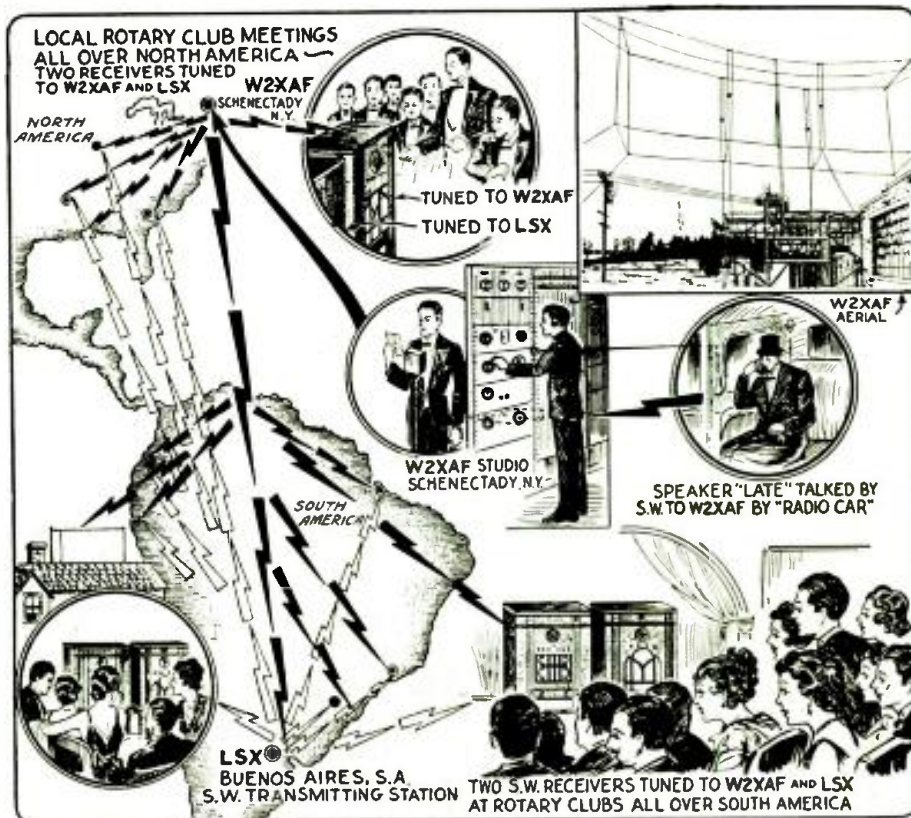

The greatest short-wave program ever staged took place recently, when a "two-way" Pan-American broadcast was arranged between joint radio meetings of Rotary clubs in Buenos Aires, Argentina and Schenectady, N.Y. Two all-wave radio receivers were placed in each Rotary Club headquarters in the various cities, one set tuned to Schenectady and the other to Buenos Aires.

ing to install two of the latest-model G-E all-wave receivers at each meeting place—ready to pick up the broadcasts of both W2XAF and LSX without the necessity of rapidly tuning from one station to the other as would have been required had only one set been used.

More than 450 members of nineteen Rotary clubs in the Schenectady district attended the local meeting and witnessed the broadcasting activities. To them, the conversations with the Argentine organization forcibly demonstrated the advanced stage of development which short-wave transmission and reception have now reached. All were impressed with the practicality, effectiveness, and immense potentialities of this new medium of communication.

Speaker's Delay Injects Surprise Feature

Walter D. Head, vice president of Rotary International, en route to attend the Schenectady inter-American broadcast, found that train connections would not enable him to arrive in time to present a prefatory address to the local assemblage prior to the scheduled conversations with Buenos Aires.

Learning of this, the committee in charge of general arrangements obtained use of the G. E. Co's., 2-way, ultra-short-wave radio police car. Upon leaving the train, Mr. Head stepped into the car, was introduced by the master of ceremonies at the meeting place, and while being driven there de-

(Continued on page 623)

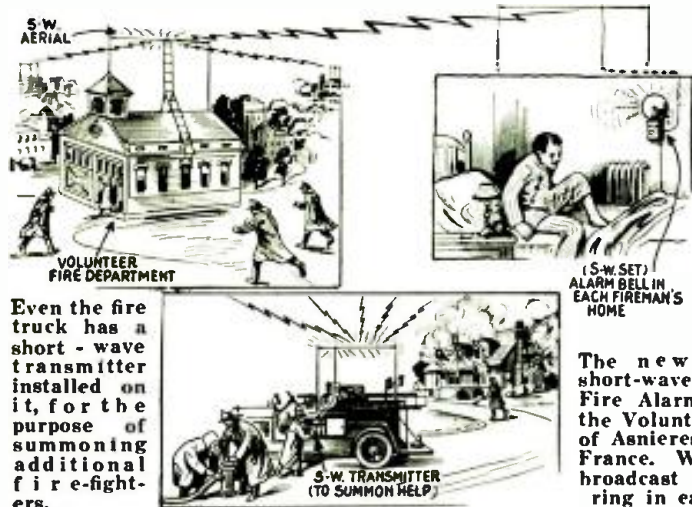

Short Waves Call Firemen

THE members of the volunteer fire department of Asnieres, a suburb of Paris, France, are summoned to duty by a short-wave alarm signal broadcast from the Fire Headquarters. When the short-wave signal sent out from the Fire House reaches the antenna of the short-wave receivers located in the different firemen's homes, it causes a bell to ring, and by coding the bell strikes, any desired information can also be simultaneously sent, such as the location of the fire, etc. This is indeed a great help as every small town in America today knows that hundreds of people are often needlessly awakened, in the middle of the night, when the town siren shrieks and starts sending out the code signals, repeated half a dozen times or more, giving the location of the fire. With the short-wave alarm system here described and illustrated the firemen are individually notified to report to the Fire House,

(Continued on page 622)

LOFTY 5 Meter STATION Atop NEW YORK HOTEL

By E. M. Lurie*

Some interesting tests have been carried out atop the "New Yorker" Hotel in New York City, and station W2DLG has been able to cover fairly great distances consistently with moderately "low power." The equipment used is designed from articles appearing in past issues of SHORT WAVE CRAFT.

Left—Arthur Lynch is shown adjusting the "long lines" oscillator.

Right—one of the operators adjusting the "beam" antenna which was used during some of the tests and which gave very interesting results. Below, a corner of the operating room of W2DLG.

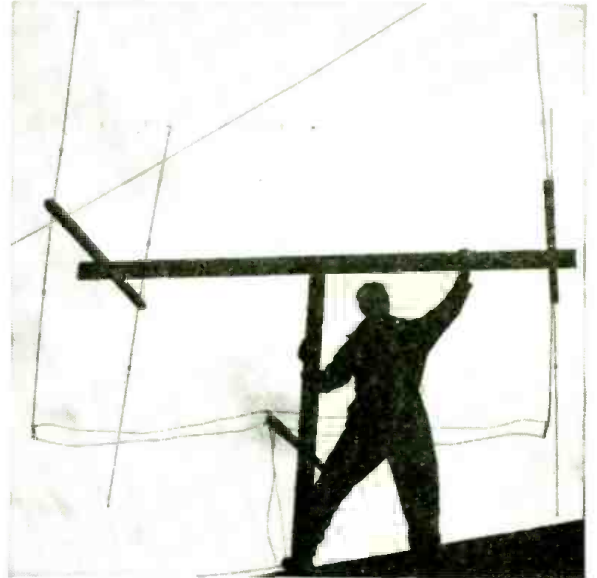
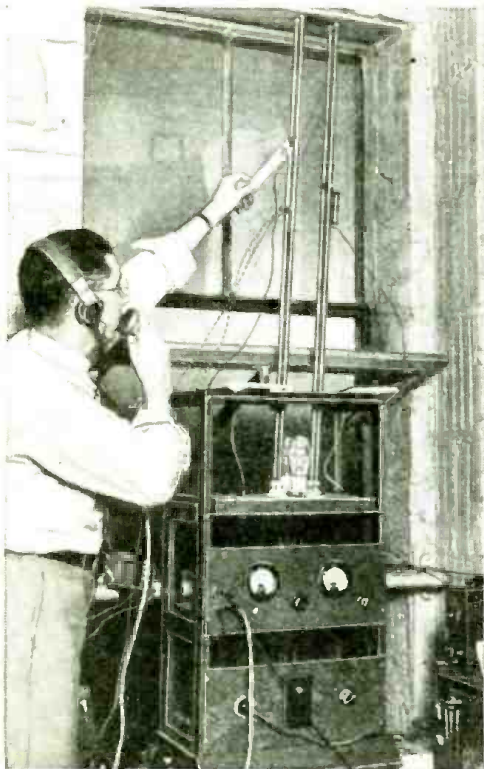

● FIVE-METER transmission and reception has, seemingly, taken the amateur radio world by storm. We believe that it is safe to prophesy that there is a fair possibility that the amateur operation in the 56-60 megacycle band, as well as in the 2½ and 1¼ meter bands, is likely to find a number of "all-wave" receivers offered for general sale next year, including these ranges as a special feature. We feel this is particularly true of wave lengths between 5 and 10 meters.

In order to truly visualize just what is going on, it is only necessary to listen in once in a while in the various metropolitan centers, where 5-meter

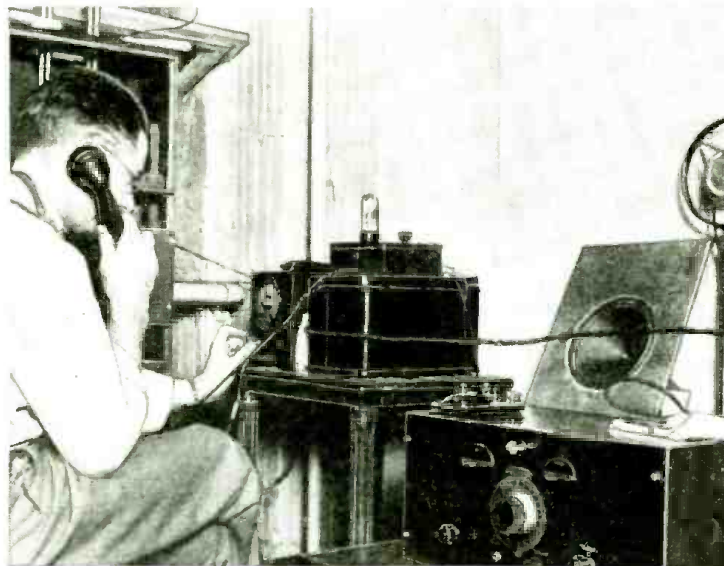

modulated by a pair of 250's, class A, energized from the same power supply as the oscillator. Approximately 400 volts is supplied to the plates of the 801's and the current drain is between 65 and 70 milliamperes. In addition to an arrangement for modulating the carrier by voice, a standard National code practice oscillator is employed for providing ICW operation.

This "rig" is putting out a signal which covers the entire metropolitan area with an intensity which is at least equal to any other New York station, although several are employing from 5 to 10 times the power in use at W2DLG.

(Continued on page 628)

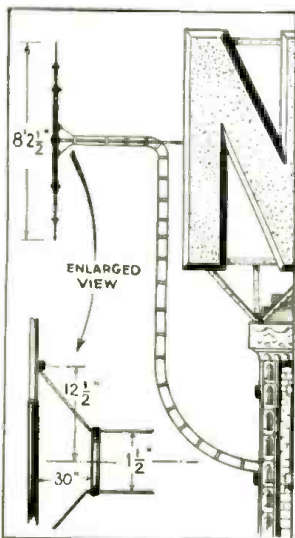

The dipole antenna and feeders used at W2DLG.

amateur activity is well under way. In some localities, such as Boston, Hartford and New York, there seems to be as much activity on 5-meter band as has been the case in the 75-meter phone band.

Duplex operation, usually difficult in the regular amateur bands, is not only possible, but is almost a general practice where telephone QSO's are conducted in the 56-60 MC channels.

From the strictly amateur point of view, this band is becoming increasingly popular because of the tremendous amount of work to be done before its potentialities are fully realized, and this offers a very wide field for individual experimentation and research.

Large Area Covered by 5 Meter "Sigs"

The 5-meter transmitter, installed by the members of the Garden City Radio Club, at the Hotel New Yorker—W2DLG—has, in the short time since its inception, been "working" with amateurs throughout the entire metropolitan area, with Princeton to the south, Baldwin, Long Island, to the east and Walden, New York, to the north, being the greatest distances covered up to this writing, November 28.

The transmitter itself is of comparative low power and is essentially a pair of 801 tubes in a "long lines" oscillator circuit,

*Chief radio engineer of the Hotel "New Yorker."



600 Feet Up! Don't let your foot slip!

Blind to Learn Radio With Braille Diagrams

● RADIO operating lends itself peculiarly to those so unfortunate as to have lost the use of their sight. However, it was not possible up until recently for a blind person to study radio diagrams or hook-ups, but thanks to the efforts of the American Red Cross, a new book on radio operation has recently been compiled in the Braille or raised letter alphabet, the diagrams being formed by a series of raised dots as shown by the accompanying picture. Thus, it is now possible for a blind student to read all about vacuum tubes, oscillations, hook-ups for various types of receivers and transmitters, how the vacuum tube operates and why, etc. Blind students may, of course, be taught the operating code of dots and dashes with comparative ease, through the sense of hearing, but—as aforementioned—until this new book had been compiled there was no treatise on radio available in the Braille alphabet.

This alphabet has special characters and one has to learn it the same as a child learns its A.B.C.'s. It is surprising how rapidly a person can read a sentence or page printed in the Braille raised letter system, when they have become proficient at it. The diagrams, of course, lend themselves to rapid reading by their very nature, the highly trained supersensitive fingers of the reader following along the lines very easily and rapidly. The names of the various parts of an apparatus, or connections in the circuits, are placed alongside each respective part of the diagram, so that as the student runs his fingers over the wire represented by the series of raised dots he will also notice and interpret the letters or name, which may be found adjacent to the respective parts.



The diagram at the left—shows the very latest in Textbooks for the Blind—a treatise on radio operating recently compiled in the Braille System, in which the lines of the diagram representing the wires etc., are represented by raised dots.



DJC—The Radio Voice of Germany

● “THE many letters of comment which have been pouring into the office since our Short-Wave Station opened its broadcasting activities on April 1, 1933, are a highly appreciated proof that our station has become a regular feature of the American Radio listener's evening entertainment,” says a special report from DJC. “It has been very pleasant, indeed, and very

helpful for the technical side of our work too, to establish this close personal touch with our U.S.A. audience. “While in 1933 our station, located at Zeesen, a village in the neighborhood of Berlin, transmitted its programs to North American listeners only, we have in the time which elapsed since, widened the circle of our radiations to South America, Africa, and

the Far East. The system of our “overseas” broadcasts will be completed by the end of 1934 by building up two additional transmitters to Central America and Australia. Zeesen is thus developing into one of the most important centers of broadcasting in Germany, and we wish that our North American listeners could not only enjoy our radiations, but also the pretty sight of our many antennas overlooking the typical Brandenburg firwoods in Zeesen. Many of our American friends have been surprised to learn that the transmitting power of our station, which they assumed, judging from the excellent reception, to be quite extraordinary, amounts to 5 kws. in the antennas only. This power has proved sufficient to reach any part of the world with adequate volume. These results have been obtained due, primarily, to use of *directional* antennas which concentrate wave beam on those zones for which it is intended. Our North American listeners certainly get the bulk of our programs, being able to tune in to Germany every night.



Chief Announcer “DJC”—Conrad Stadler (left); Chief Announcer “DJA”—Hans-Juergen Maraun.

Right: The short-wave station and aerial masts at Zeesen, near Berlin. Below: “Broadcasting House” Berlin, where the studios of the German short-wave station and of the Deutschlandsender and the Reichssender Berlin are located.

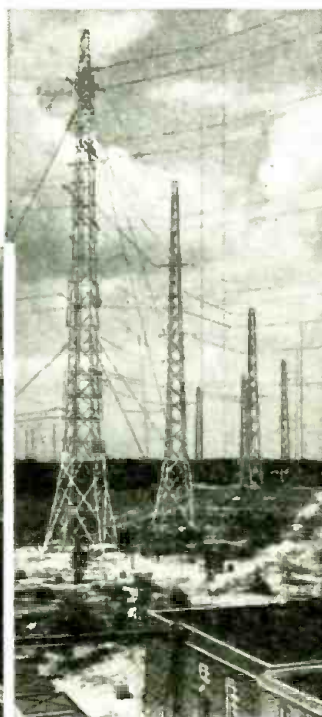



The recording machine shown in the center of the photo is that designed and built by the Universal Microphone Company and handles full-sized records. The lead-screw propels the recording head across the record so that it can cut the grooves as it moves along. The magnetic pick-up is shown at the rear of the machine and the headphones serve as a monitor.

● THERE is a fertile field in short wave radio which has not, so far, been paid much attention by the average listener. This field is home-recording of programs from short-wave stations. Home-recording offers many possibilities, novel and useful. How many times has a short-wave "fan" wished to convince skeptical friends of his prowess in bringing in "foreign" programs on his short-wave set, only to find that with visitors present, receiving conditions are "hopeless" so far as *foreign* reception is possible?

With home-recording the embarrassment suffered by the "fan" can be dispensed with, for, even if conditions are poor the triumphant listener can bring forth a record of a "foreign" station which he made *when reception was good*. In the face of such proof a skeptic has no alternative but to admit defeat. In addition to satisfying one's ego, home-recording offers the means to capture, for permanency, some interesting event or some item of sentimental or humorous value to the listener. A



Special Universal recording head for the more "ambitious" short-wave fan; this head actually cuts the groove in the record, a lead-screw propelling it across the disc.

Recording of short-wave programs is rapidly becoming more popular; practical hints are given here on how to do this. Recording apparatus is available to suit practically every purse; you can start in by simply using an ordinary magnetic pick-up and pre-grooved records. Record that "foreign" station and prove to your friends that you actually received it!

case in point was the recent marriage of the son of the King of England to Princess Marina of Greece. The entire ceremony was broadcast on *short waves* to the "whole world" from Daventry. The listener who was foresighted enough to make a recording of this event has a unique souvenir for the years to come. A third possible use of home-recordings is to use them as verification seeking letters. Instead of copying down the items heard and writing in for a verification, make a home recording of the program on a small disc and send the disc, together with a special needle and instructions for playing it. The station will not only be satisfied with your "proof" of reception, but will be pleased to get a first-class idea of how their station is being received abroad. The cost of such a "veri" is higher than merely writing it on paper,

but it is sure to achieve results, since 99 per cent or more of all s-w stations use phonograph records on their programs and will find it a simple matter to play back the record. In one authenticated case in which a listener in Chicago made a record of a musical program from Australia and sent the record to the station, the listener was surprised to hear the same station several months later playing his record over the air and mentioning the fact that he had sent it to them! The ingenious experimenter can doubtless develop many more uses for home-recording. The ideas mentioned in this paragraph are given solely as the starting point for individual initiative.

Several Methods of Recording Programs

There are several methods of making



The RCA Victor store type recorder, model R92, is equipped with "mike" amplifier and motor.

phonograph records at home which are suitable for use with equipment available to the average layman. As with everything else there is equipment to meet everyone's purse. The more expensive equipment, as would be expected, gives superior results but even with simple, inexpensive equipment results may be secured which will please even the most skeptical. The simplest method makes use of an ordinary electro-magnetic phonograph pickup which is used to reproduce standard records through the amplifying system and loud-speaker of the ordinary radio set. Many listeners have phonograph pickups which may be used but if the listener has none one can be procured from a radio supply house or dealer at a price of from two to fifteen dollars, depending upon the quality. The pickup must be of the magnetic type; crystal or condenser type pickups are not suitable. To make a home-recording with this equipment the pickup is used as a recording head (a recording head is a device which converts electric impulses from a radio set into mechanical motion, which is in turn impressed on a soft record in the form of grooves on the surface of the record). A blank pre-grooved record is required. There are two types of recording discs available, pre-grooved and un-grooved. The pre-grooved record is supplied with un-modulated grooves to permit the recording head to follow a spiral path when recording. The recording head modulates these grooves so that when the record is "played back," music, etc., will be heard. The un-grooved record is superior in that there is less *needle scratch* heard when playing a finished record and more faithful reproduction is obtained. The un-grooved record requires a *feed-screw* mechanism to cause the recording head to travel over the surface of the record while recording; it is naturally a more expensive mechanism. (It is described in greater detail in a later paragraph.)

Simplest Method

The pickup is connected to the output of the radio set through a suitable "matching" transformer, a special recording needle is placed in the pickup and the pre-grooved disc is placed on the turntable of the phonograph. When a program is tuned in on the short-wave set and the volume turned up to a little more than average room volume, the needle in the recording head will vibrate to the electrical impulses from the radio set. The recording head is placed at the beginning of the record. A weight must be placed on the recording head while recording; the proper weight for recording on aluminum blanks is about 10 to 14 ounces, on composition blanks (such as RCA Victor home-recording blanks) the proper weight is around 10 ounces. When the turntable is started and the record is rotating at the proper speed (78 r.p.m.) place the recording head on the starting groove of the record. The program that is being received on the receiver will be recorded on the disc, providing that the volume is sufficiently great.

The composition type of record requires a much louder signal for a good recording than does the aluminum. For this reason an amplifier with an undistorted output of at least 2 watts is necessary. A larger amplifier is preferable for superior results; this amplifier should be capable of delivering a

(Continued on page 618)

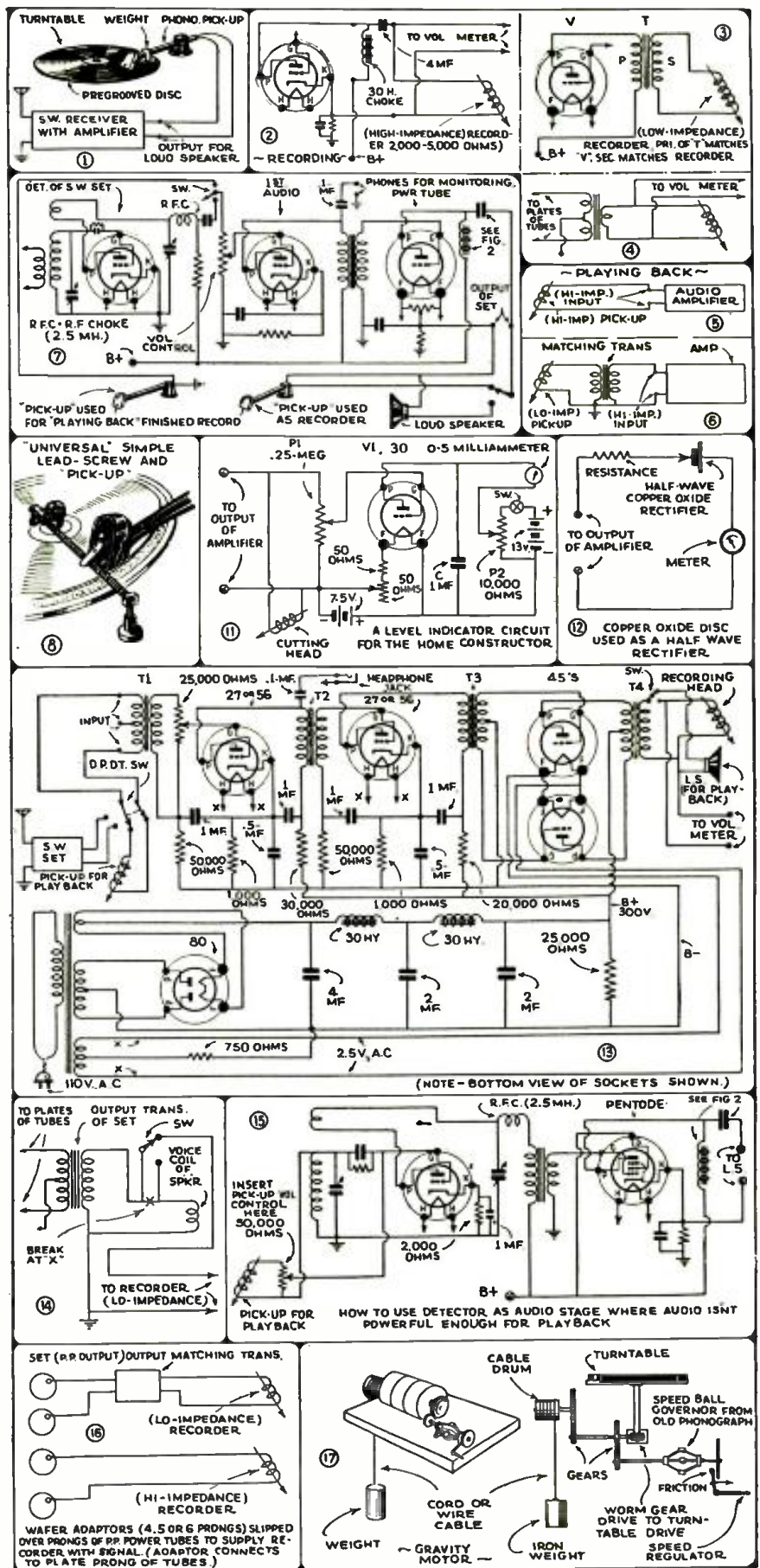

Fig. 1—Using magnetic pick-up and "pre-grooved" disc for recording short-wave programs. Figs. 2, 3, and 4—Various hook-ups for "recording." Figs. 5 and 6—"Playing back" hook-ups. Fig. 7.—Use of two magnetic pick-ups for "recording" and "play-back." Fig. 8—Simplest "Universal" lead-screw and recorder pick-up arm. Figs. 11 and 12—Volume "meter" hook-ups. Fig. 13—Complete power amplifier for "Recording" and "play-back." Fig. 14—Switching "recorder" and "speaker." Fig. 15—Using detector as audio stage "booster." Fig. 16—Using "wafers" to attach recorder to audio output tube. Fig. 17—"Gravity" motor for recording.

ECONOMY-3—A "High

By **GEORGE W. SHUART,**
W2AMN

this author's intention to condemn them. This battery set is offered for those who want an efficient battery-operated receiver.

The advantages of this set rest entirely in the type of tube used. It is a *screen-grid pentode* tube having an *indirectly heated cathode* and its characteristics make it particularly well suited to short-wave reception. The "Economy 3," so named because it is really economical to run and offers high efficiency, has a stage of tuned R.F., a regenerative detector and one stage of audio amplification. The set is intended for earphone operation and will not operate a loud speaker. The volume on the phones is so great that some of the stations actually hurt the ears! Even those "hard to get" stations can be brought in with full earphone volume. The R.F. stage uses five prong coils of the two-winding variety; one winding is for antenna coupling and the other for the grid coil. These are the new Na-Ald band-spread coils and permit the "crowded" bands to be spread over a goodly portion of the dial, making tuning very simple. The R.F. stage is equipped with a small condenser, having 50 mmf. capacity, for trimming the circuit and keeping it in alignment with the detector stage. This is necessary because the two circuits of the detector and the R.F. stages are "ganged" in order to have what amounts to *single-dial* tuning. The coils are made in three varieties, namely—short-wave broadcast band-spread, short-wave amateur band-spread, and "general coverage" coils which cover the entire range of from 15 to 200 meters. This makes the set adaptable to "Fan" or "Ham" requirements.



Here's a front view of the "Economy 3" in actual operation. Note its extremely neat appearance.

● MANY of our readers have by this time built the "Economy 2" because it offered something distinctly better in the line of "battery-operated" short-wave receivers. The fine results obtained with the two tube set induced the writer to build this three tube tuned radio frequency receiver using the same type of tubes. As we have said before the type 15 tube offers a real opportunity to the "battery" set constructor.

Advantages of Battery Sets

Battery-operated short wave receivers, if they can be built efficiently, offer

something that can not be obtained with an A.C. operated set. First the battery set is by far the most *quiet* receiver that can be built. There is no hum whatsoever, and there is no noise such as is sometimes introduced in an A.C. set, through the power lines. Then again, the voltage supply in a battery set is absolutely constant, provided good batteries are used, and this is just about impossible to obtain in an A.C. operated outfit. The above features alone should convince the most critical fan. However there are advantages in an A.C. operated set, and far be it from

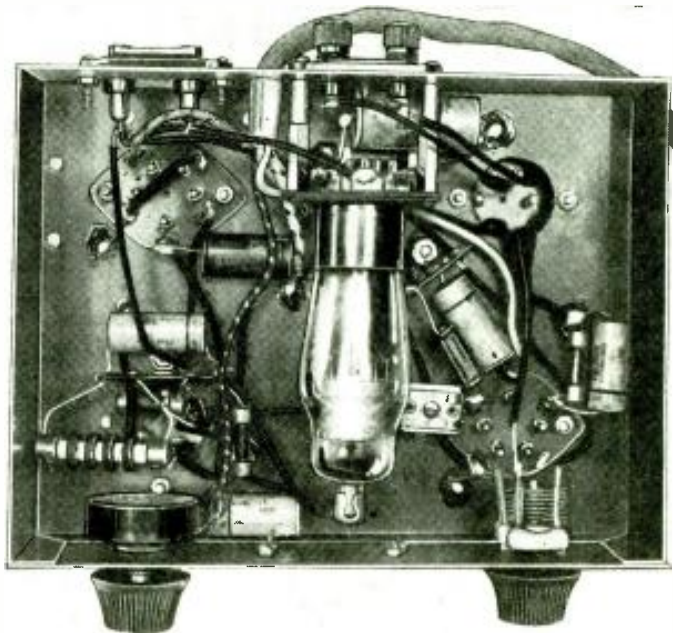

Left—Rear view of the "Economy 3" showing the placement of parts. Right—Underneath view—note that one of the tubes has been mounted under the chassis in order to simplify wiring and make the receiver more compact.

Gain" Battery Set



Battery Drain Low

As in the two tube set described last month, this set has the filaments of the tubes connected in series to allow economical use of batteries. When connected in this manner the filament power required is 6 volts at .22 ampere. This is provided by four dry cells connected in series and they will give months of service. The plate power for the set is provided by two or three 45-volt standard "B" batteries. Three batteries giving 135 volts will give slightly increased sensitivity. However the 90 volts give very fine results. The total plate current required is very low, which spells long battery service.

Coupling between the R.F. and detector stages is capacitive. While inductive coupling may have its advantages, the above method serves excellently and was used in order that the band-spread feature could be easily incorporated. With six-prong three-winding coils, inductive coupling is possible but these coils, as yet, are not made in band-spread form; it would require a seven-prong coil form and this type of coil is difficult to construct. The parallel condenser method of band-spread could have been used with the six-prong coils, but this would have necessitated the use of two more controls, adding greatly to the complexity of the receiver. The detector is a grid-leak condenser affair with the tickler connected in the cathode circuit. This produces a very smooth and stable operating circuit. Regeneration in the detector is controlled by a 50,000 ohm potentiometer connected in the screen-grid lead. By varying the screen-grid voltage in this manner, there is a minimum effect of *detuning* the grid circuit. A 1 mf. bypass condenser connected across the potentiometer, together with a well-constructed control, eliminates all noise from this source. The audio stage of this receiver is exactly the same as that of the two tube set. The screen-grid of the 15 audio amplifier is connected directly to the plate and gives us a high-mu triode. The pentode connection of the 15 tube will not match the earphones and the triode connection becomes a necessity.

Layout Hints

The entire receiver only measures 8 1/4" wide, 6 1/4" deep, and 7 1/4" high. This is really a "compact" set and we believe you will agree that with its crackle-finished panel and cabinet it is extremely neat in appearance. Looking at the rear view of the chassis we find that the R.F. stage is on the right, with the coil in front of the tube. The detector is on the left, with the coil located behind the tube. This arrangement brings the tuning condenser between the two stages, with all leads very short. Where is the audio tube? Look at the other photograph showing the bottom view, and we find that it is under the chassis! Crazy? Not at all! This position is just right: it allows shorter leads to the tube, easier wiring, and allows the set to be built on a much smaller chassis without crowding the parts. The position of

the tube is not critical in the indirectly heated cathode type tube, so there is no danger of a sagging filament. The detector and R.F. coils are mounted with their sockets above the base of the chassis, in order to reduce losses, caused by the windings being close to the chassis. A simple shield forms a partition in order to keep the constructional cost and labor as low as possible. In constructing the set endeavor

(Continued on page 639)

the tube is not critical in the indirectly heated cathode type tube, so there is no danger of a sagging filament. The detector and R.F. coils are mounted with their sockets above the base of the chassis, in order to reduce losses,

caused by the windings being close to the chassis. A simple shield forms a partition in order to keep the constructional cost and labor as low as possible. In constructing the set endeavor

(Continued on page 639)

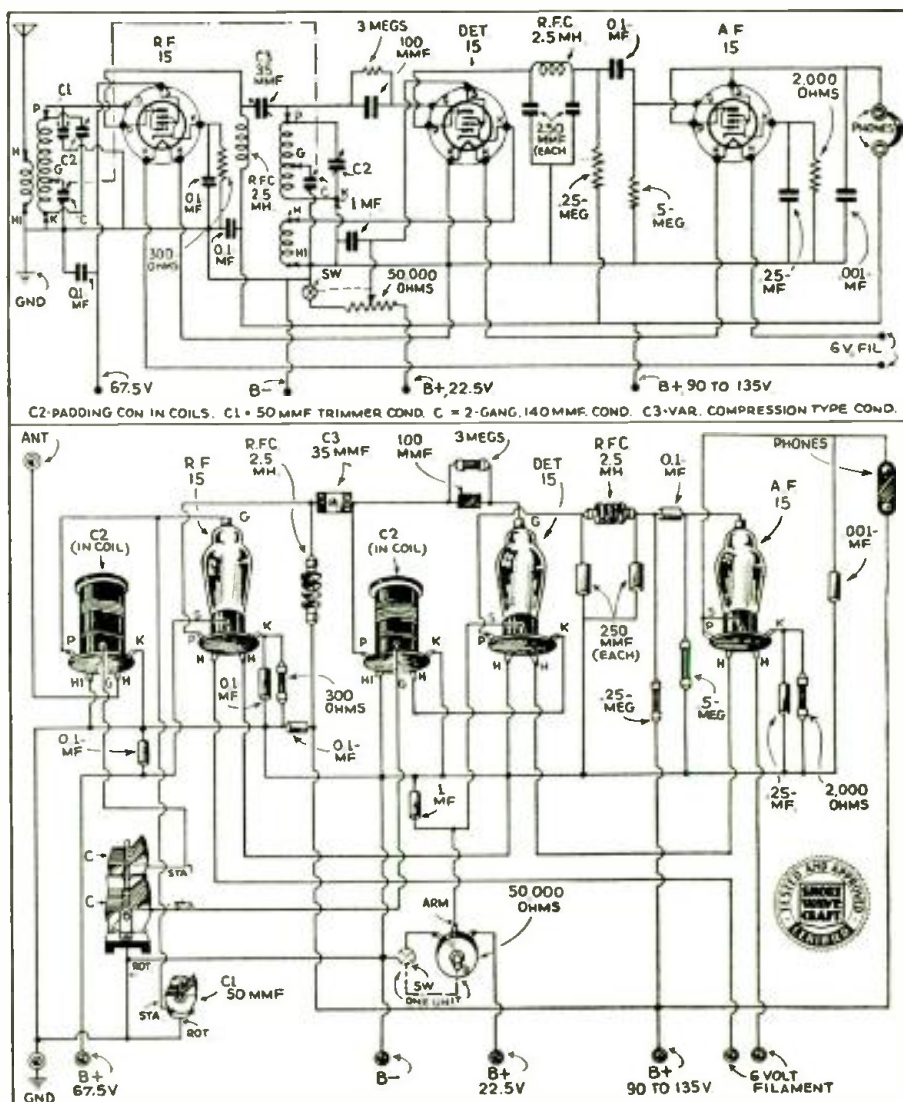

Physical and schematic wiring diagrams of the "Economy 3" battery-operated receiver.

3 Tubes=6

By M. HARVEY GERNSBACK

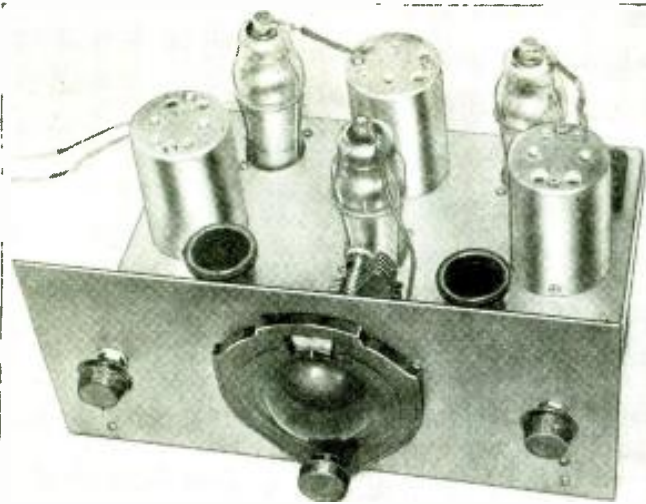

Front view of "3 tubes=6" Super-het. European musical and vocal short-wave programs "rolled in" like nobody's business on this marvelous 3-tube receiver, which actually does the work of 6 tubes.

● THERE are now a number of multi-element "double-purpose" vacuum tubes on the market, such as the 6B7, the 6A7, the 6F7, etc. By suitable selection of these tubes it is possible to build a receiver using only 3 tubes which will give the performance of a much larger receiver. The set described uses a 6A7 as first detector and oscillator, a 6F7 as first I.F. amplifier and audio amplifier and a 6B7 as second I.F. amplifier, second detector and delayed A.V.C. tube. Three tubes perform 7 functions! The 6A7 is a pentagrid converter, the 6F7 a combination of a variable mu R.F. pentode and a separate triode, both sections of the tube employ a common cathode. The 6B7 consists of a variable mu R.F. pentode and 2 separate diodes. The 2

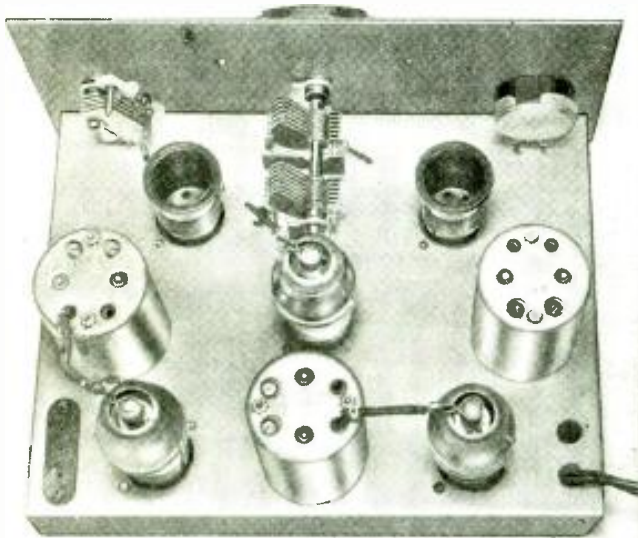

Rear view of "high efficiency" Super-het, designed to make maximum use of the latest "double-purpose" tubes. Three tubes perform seven functions!

pentode units are used for the I.F. amplifier stages with A.V.C. applied to one of them (the 6F7); the triode is used as the audio stage and the 2 diodes as second detector and A.V.C.

By careful layout and circuit design it is possible to make this set perform as well as the conventional 6 or 7 tube "super-het." One of the most important parts of a "super-het" is the *mixer* stage, that is the first detector and oscillator circuit. Unless the mixer unit "mixes" suitably, all the I.F. amplification in the world will not bring in *loud* and *clear* signals. Poor "mixer" design is a frequent cause of low signal-to-noise level ratio in *super-hets*. While it is undoubtedly true that R.F. amplification preceding the mixer circuit results in a great improvement in the signal-

to-noise ratio, it was felt that the addition of R.F. amplification to a small set of this type would be a needless complication, particularly as the "mixer" stage is quite efficient in this set. Subsequent results showed the truth of this belief as the *noise-level* is very low in the finished set. The tuning of the first detector grid circuit is also quite sharp which minimizes tendencies to "image frequency" pick-up.

Not a "Freak" Set

It should be understood that this is not a freak set requiring careful manipulation of many controls. There are only 3 controls—volume, main tuning, and antenna trimmer. None of them are critical. As constructed the receiver is for headphone use. However the addition of a resistance coupled power stage employing a pentode (either a 41 or 42) will give full loud-speaker volume, even on European stations! An extra audio stage of this type was set up beside the receiver and connected to a 12-inch dynamic speaker; Daventry GSD was tuned in and it was necessary to reduce the volume to enjoy the program!

The construction of the set offers no difficulties provided the specified layout is followed. The main tuning condenser is a 2-gang affair, with 140 mmf. capacity in each section. The 1st detector and oscillator coils are of the 4 or 5 pin plug-in type. They are standard coils with 2 windings, grid and tickler. Several turns must be removed from the grid windings of the 2 largest oscillator coils (the ones tuning from 45-200 meters) to make them track properly. The antenna trimmer condenser has a capacity of about 35 mmf.

The I.F. amplifier stages follow conventional lines. The constructor should note the thorough decoupling of all plate and screen voltage supply leads to prevent oscillation in these stages. All isolating resistors and condensers should be wired into the set as close to the tube sockets and I.F. transformers as possible. The standard I.F. transformers generally have a lead for the control grid brought out through the top of the transformer to be connected to the control grid cap on the tube. It is necessary to remove one of the I.F. transformers from its can and remove this control grid lead. In its place solder a wire the same length as the other connecting wires of the transformer. This wire should be covered with metal shielding braid to within a half inch of the point where the wire is soldered to the transformer. This wire should be brought out through the *bottom* of the transformer together with the other leads. The reason for this alteration is that the second detector is a diode and the diode connection must be made to the base of the tube *and not to the cap*.

The "plate," and "Control grid" leads on all the I.F.

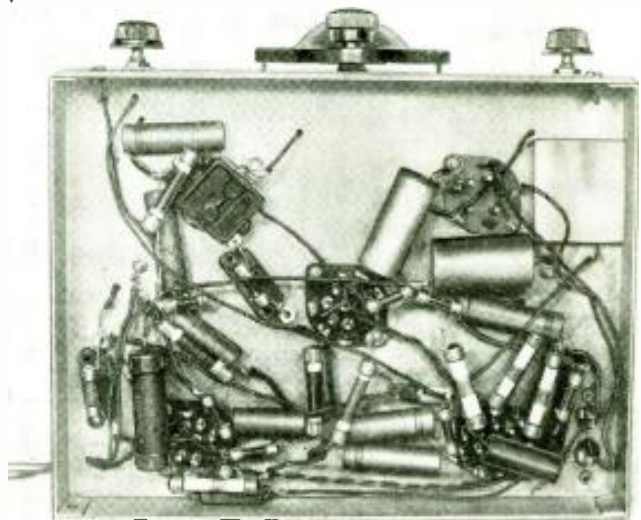

Bottom view of "3 tubes=6" Super-het. The set is simple to build and of low first cost.

In This SUPER-HET



transformers should be covered with shielding braid if they are not supplied with this already done. (If the constructor does not wish to disassemble the transformers to put the shielding on he may shield the wires from the point where they emerge from the I.F. transformers. The shielding should be well grounded to the chassis by soldering it to lugs mounted on the screws holding the I.F. transformers and sockets to the chassis. It is advisable to connect together with a piece of heavy wire all the grounding points on the chassis to ensure that no stray currents are circulating on the chassis.

It will be noticed that the volume control is in the form of a potentiometer varying the screen potential applied to the first I.F. tube. While this may seem a poor method of volume control it was the most satisfactory one to be found. Many different types were tried without good results. In fact selection of a satisfactory means of volume control was the most difficult point encountered in designing this receiver.

The A.V.C. action is surprisingly effective, considering the fact that it was possible to control only one tube satisfactorily. It will be found that it does not reduce "gain" quite enough on

● Economy, plus efficiency, spells the ultimate goal of good design in short-wave sets today. Mr. M. Harvey Gernsback here gives us a dandy Super-Het and it actually duplicates the work of six tubes with only three tubes. A 6A7 acts as first detector and oscillator; a 6F7 as first I.F. amplifier and audio amplifier; a 6B7 as second I.F. amplifier, second detector and delayed A.V.C. Actually 3 tubes perform 7 functions! This is the "line-up" for head-phones; for "loud-speaker" operation an additional audio stage is described.

extremely strong signals. In this circumstance it is necessary to use the manual control to reduce the signal to a point where the A.V.C. will successfully function. The A.V.C. has a delay potential of about 15 volts applied to it. In other words it will not begin to function till a signal of at least 15 volts is applied to the A.V.C. diode. This is done so that weak signals will not be reduced by the A.V.C. action. Without it the A.V.C. would function and reduce sensitivity even on the weakest signals.

Aligning the I.F. Stages

It is advisable to have an 0-25 mil. millimeter available for this process. Connect the set up and plug in the set of coils covering the 49 meter band (No. 3) 1½ turns should be removed from the grid winding of the oscillator coil in set No. 3. Assuming that this has been done, tune over the dial till a signal is picked up. Bring it up to maximum by means of the antenna trimmer. Connect the millimeter in series with the B plus lead to the receiver. With 250 volts applied to the set the meter should read between 20 and 25 mils (milliamperes). Start with the set-screw condensers on the first I.F. (Continued on page 635)

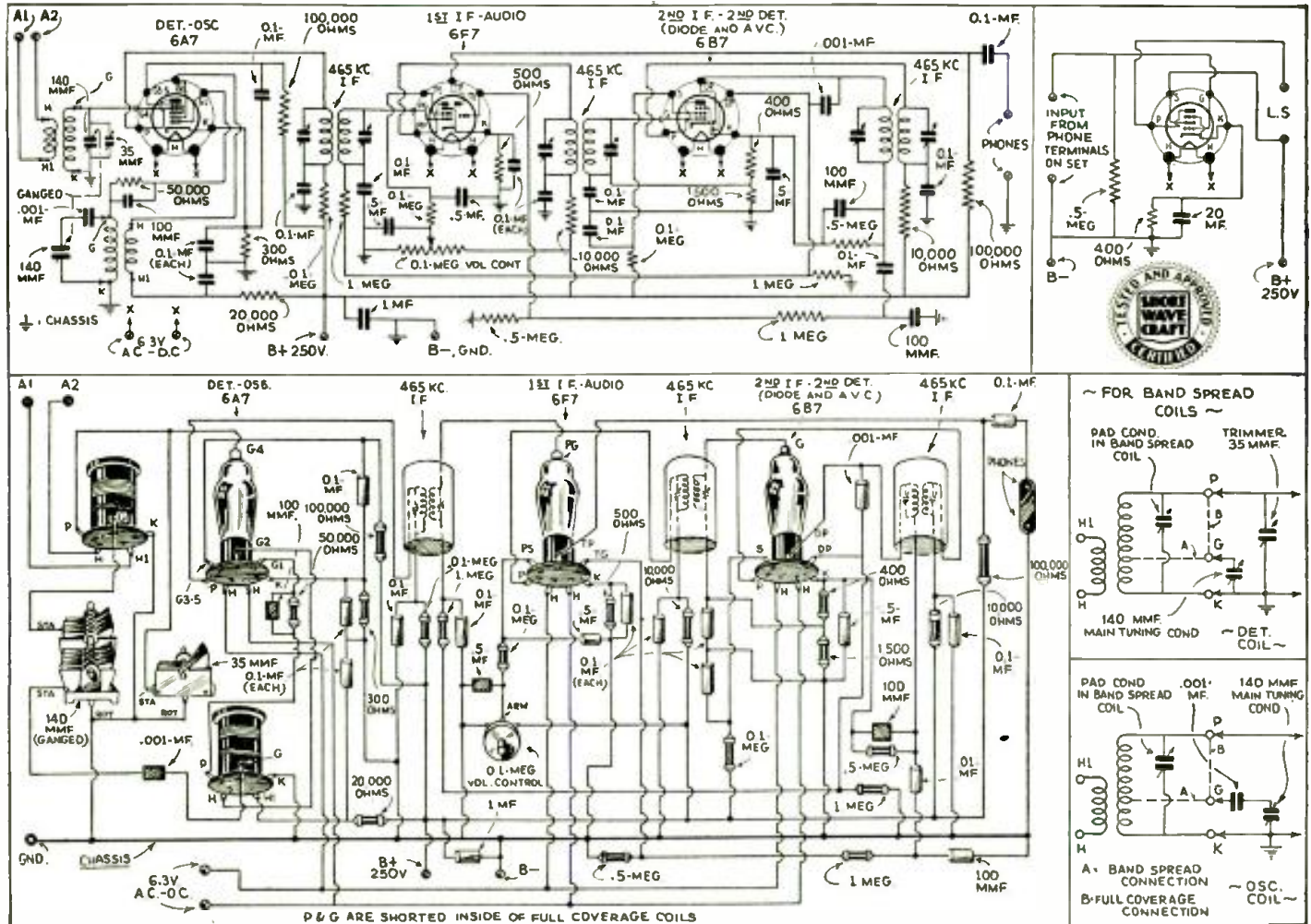

Wiring diagrams, schematic and physical, are given above for the "3 tube=6" Super-het. No trouble should be experienced in building this remarkable receiver. It has automatic volume control and "all the trimmings."

WORLD-WIDE SHORT-

The Triode Hexode—A New Tube

● UNTIL recently, designers of short-wave equipment have had to utilize tubes which were made for use on lower frequencies and make the best of a bad situation.

The demand for better parts—and especially tubes—has brought several new tubes, such as the RCA "Acorn" tube into existence.

When the pentagrid-converter tube was first introduced, set builders hailed it as the answer to all problems of superheterodyne construction. Here was a tube which answered all the problems without introducing any new ones.

But like all other "cure-alls" the pentagrid tube also has its faults—among which is a tendency to stop oscillating at high frequencies, above a certain critical frequency—which limits its use in short-wave sets. This is caused by a feed-back of energy from the oscillator plate (grid) to the control-grid, through the inter-electrode capacity, for the shielding between these electrodes is necessarily imperfect.

This feed-back causes a degenerative effect which reduces the over-all gain of the tube and on high frequencies, where the impedance of the inter-electrode capacity is low, it actually stops the oscillator from functioning.

In order to overcome these disadvantages, a new electron-coupled frequency converter or translator as it is sometimes called, has been designed in England. This new tube was



described in *Wireless World*.

It consists of two separate tubes built into a single envelope—one a triode and the other a hexode—hence the name. The hexode has six electrodes, a cathode, a control-grid, two screen-grids, a coupling-grid and a plate. The control-grid immediately surrounds the cathode and is itself surrounded by the first screen-grid. The coupling-grid comes next and is separated from the plate by the second screen-grid.

The coupling-grid is connected internally to the triode (oscillator) grid. This grid is surrounded by the triode plate, and the

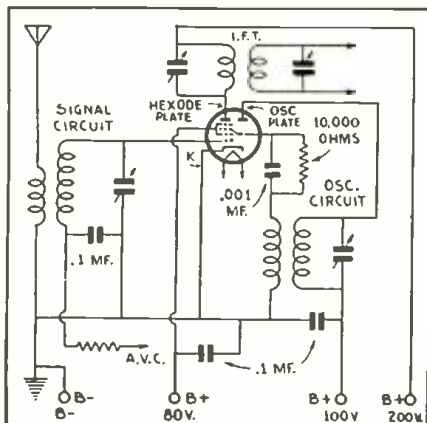

Hook-up for the new English "Triode-Hexode" tube.

● The Editors have endeavored to review the more important foreign magazines covering short-wave developments, for the benefit of the thousands of readers of this magazine who do not have the opportunity of seeing these magazines first-hand. The circuits shown are for the most part self-explanatory to the radio student, and wherever possible the constants or values of various condensers, coils, etc., are given. Please do not write to us asking for further data, picture-diagrams or lists of parts for these foreign circuits, as we do not have any further specific information other than that given. If the reader will remember that wherever a tuned circuit is shown, for instance, he may use any short-wave coil and the appropriate corresponding tuning condenser, data for which are given dozens of times in each issue of this magazine, he will have no difficulty in reconstructing these foreign circuits to try them out.

latter two elements form an entirely separate tube, joined with the hexode only by the coupling-grid which provides the desired electron coupling.

Variations in the oscillator plate voltage have no effect upon the screen and plate currents of the hexode, and changes in the hexode screen, plate, or control-grid voltages do not alter the oscillator plate current.

It will thus be seen that the triode-hexode offers important advantages over other frequency changers in that, while it is non-radiating and can be controlled from the A.V.C., it gives complete freedom from interaction between the signal and oscillator circuits and also a lower level of background hiss. These points are important in broadcast reception, but they are doubly so on short wave lengths.

Direction Finding With "Ultra Shorts"

● RECENTLY in this page, we mentioned some experiments which appeared in *Wireless World*, regarding the reception of ultra-short waves with loop aerials. In this résumé, we pointed out that much work remained to be done along the lines of development of aerials and radiating systems for ultra-short wave transmission and reception.

In a more recent issue of the above publication, some further details have been presented, including an explanation for the apparent discrepancy in the direction of transmission of the very high frequency waves.

It will be remembered that with a horizontally polarized transmitter, it was possible to receive signals with a vertically polarized loop, but with its plane at right-angles to the direction of the transmitter.

In the later article, it is shown how this is possible. If the loop is pointing toward the transmitter, as at A in the accompanying sketch, a signal will be picked up in the loop. Now, if the loop is maintained in the same position, but the transmitter polarized in a horizontal plane, the field is everywhere at right angles to the winding of the loop, and therefore produces no EMF in it; this position gives minimum signal strength. But if the loop is set as at C, the electrical field will be parallel to its top and bottom, and will induce in these two sides EMF's which are opposed to each other around the loop. Since all parts of the loop are now equidistant from the transmitter, the two EMF's should have the same magnitude and phase, so that the resultant EMF around the loop would be zero. But, if for any reason, the field is non-uniform in the vertical plane so that the EMF, say, in the top of the loop is greater than that in the bottom, there will be a resultant EMF around the circuit.

In practice, the presence of the receiver,

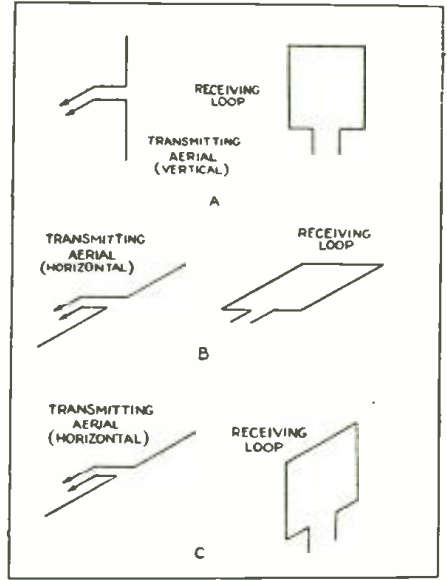

Diagrams showing how to use "loop" aerials for ultra short-wave work.

just below the loop will probably cause sufficient distortion of the field, while there is also the effect of the earth to be considered, so that reception in this way becomes possible.

Put Your Aerial Underground

● A WELL-known English radio writer, in a regular column in *Amateur Wireless*, recently pointed out the possibilities of the underground aerial for short-wave reception.

It appears that the writer was told about this type of collector, and tried it by burying a 30-ft. length of garden hose through which a wire had been threaded, 2 feet deep.

The results were a somewhat lower signal strength, as compared to a good overhead aerial, as might be expected. But, the noise-to-signal ratio was much improved, especially with regard to such noises as passing automobiles and street cars.

Different lengths of buried wires were tried, but the original 30-ft. length seemed to be the best length, as shorter wires reduced the pick-up too much, while longer wires damped the set and prevented correct operation.

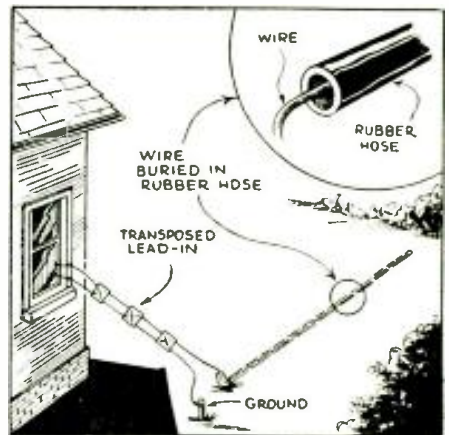

Here's a clever way to try out an underground aerial for short-wave reception, the wire being placed inside a length of garden hose and buried 2 feet underground.

WAVE REVIEW

Edited by
C. W. PALMER

A New Short-Wave Tuning System

● EVERY experienced radio experimenter knows to what extent the inductance-to-capacity ratio of any short-wave receiver's tuning circuit controls the set's performance. Briefly, the more inductance and less capacity there is in any tuning circuit, the more effective and more sensitive it will be.

A writer for the Austrian publication, *Radio Amateur*, recently devised a system which includes many novel features, and approaches the ideal mentioned above, very closely.

The accompanying circuit shows the scheme. The variable condenser C3 does not tune the circuit, for owing to the effect of the "neutralizing" condenser C1 in the aerial lead, its capacity can be regarded as practically non-existent and the capacity of the condenser C2 can also be disregarded for the same reason.

The only duty of these two condensers is to introduce the aerial current into the coils L1 and L2 and in fact, these two con-

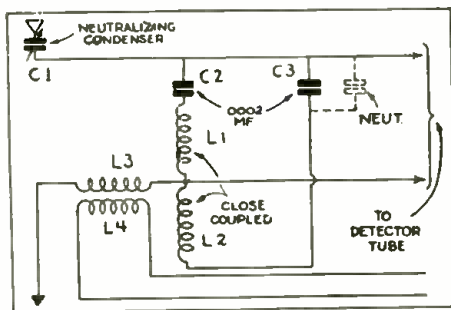

An improved short-wave tuning circuit which achieves the ideal balance of inductance to capacity.

densers make the working capacity of the circuit less than if they had not been included.

In the experimental set-up described by the author, the values of the coils are: L1, 6 turns; L2, 6 turns; L3, 2 turns and L4, the regeneration coil, 8 turns. Coils L1 and L2 are close-coupled and may be wound on a single tube, as can coils L3 and L4.

It must be kept in mind that coils L1 and L2 must be of the same inductance, but the degree of matching is not critical and of course, they may contain any desired number of turns, but coil L3 and the regeneration coil are best followed as specified.

The theory of the circuit is that when the moving plates of the variable condenser are all the way out, almost all of the aerial current flows through C2 to coil L1, but a little, owing to the end plate capacity of the variable condenser gets to coil L2, which is close-coupled to coil L1, so that the magnetic fields of the two coils neutralize each other to a greater or less extent.

(Continued on page 625)

Short-Wave Chokes

● THE construction of efficient choke coils for short-wave receivers has caused more than one experimenter to throw up his hands in disgust. This is especially true when air-core chokes are attempted.

It is well known that R.F. chokes having no insulating tube or form are more effective than those wound on wooden cardboard, or bakelite forms. But it is difficult to make such coils which will be rigid enough to stand the abuse they naturally receive in set construction.

A recent issue of *Amateur Wireless*,

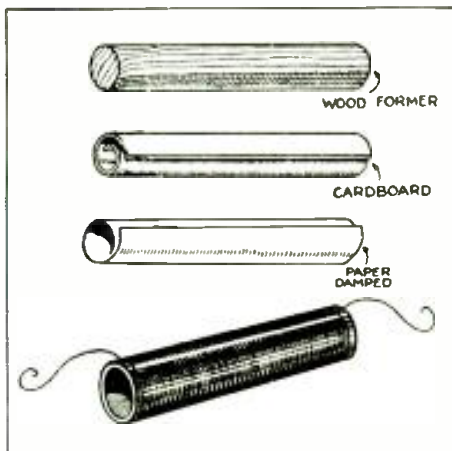

The sketch above shows an improved method of making short-wave chokes.

an English publication, gave a simple but effective method which can be accomplished by anyone.

A wooden rod, slightly smaller than the desired diameter of the choke, is procured. Over this is wound a layer of rather stiff cardboard and over both, a layer or two of dampened paper. The wet paper will effectively hold the cardboard in place.

Then Duco cement is squeezed lengthwise over the paper at intervals around the form. Finally the wire is wound on, using any of the usual methods of winding, such as fastening the wooden rod in the chuck of a hand drill.

When the required number of turns have been wound, the Duco cement, which has oozed through the wire should be spread over the outer surface of the winding, and additional cement should be added to form a complete layer over the wire. The cement can be spread with a finger which has been well moistened to prevent the cement from sticking.

(Continued on page 616)

Improving Plug-In Coils

● IN describing the construction of a new receiver, a recent issue of *Toute la Radio*, a French magazine, included a useful kink for improving the efficiency of plug-in-coils.

By cutting partly through the base of the coil with a hack-saw, between the various pins which make contact with the socket, the length of insulation between pins is increased and the amount of insulation is reduced, both of which are desirable features.



The trick shown above will considerably reduce high frequency losses in plug-in coil forms.

The Paris Radio Exhibition

● WE have reviewed in these columns the radio shows which were held, this year at Olympia, in England, and at Berlin, Germany. And now we have the eleventh annual show held in Paris, at the Grand Palais.

While the number of short-wave items appearing at this show is less numerous than at the other two shows, several really novel and worth-while items have been displayed in French magazines describing the show.

The first of these is a spiral dial with a traveling pointer which follows the spiral, as shown in the sketch, here. This automatically produces a vernier tuning action, due to the unusual length of the tuning scale, but also permits notations and loggings to be made directly on the scale, which is extremely useful for the short-wave receiver. The tuning can be accomplished either with a dial or crank at the end of the scale, as shown, or a cable drive could be attached to permit a knob to be used.

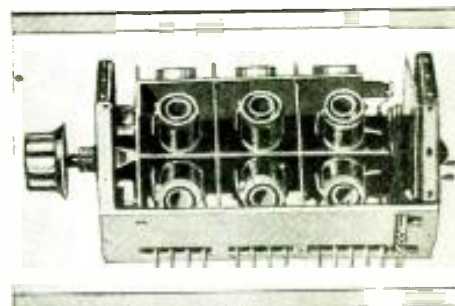

In the recent French Radio Exhibition, the "all-wave" tuning coil system illustrated above was shown. The coils being placed in separate shielded compartments.

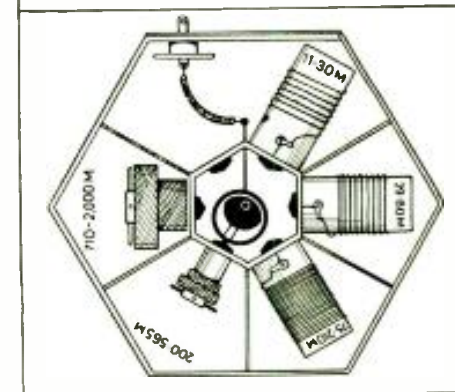
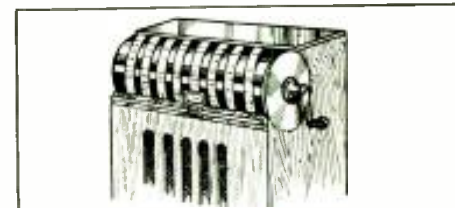

The lower drawing in the group above shows the arrangement of the Cam switch used in the new French all-wave tuning coil assembly, while the upper picture shows the new French spiral dial with a traveling indicator which follows the spiral.

The second item is an interesting all-wave tuning system, which has coils arranged in a circle, in individually shielded compartments, and a cam switch (differential) included as an integral part of the assembly to permit shifting from one band to another. The arrangement permits the coils to be completely shielded, and still maintain exceptionally short leads, and the switch, which is usually the stumbling block in such complicated setups is actually more simple and more pos-

(Continued on page 633)

OFFICIAL LISTENING POST REPORT

From John Sorensen, Bronx, N.Y.

● MOST all the G, D and F stations have been received well, except FYA on 25.6 meters. PH1, PCJ, EAQ, ORK, LSX, PRF5, HBP, HBJ, I2RO, JRM, WQO, WEL, WEF, KEE, KWO, KWC, HC2RL, YV5RMO, TIEP, OA4AD, OAC4B—48 meters. PRAD10, HJ1ABB, HJ1ABD, RNE, RW15, WQP, OXY, LKJ1, VK2ME, VK3ME, VK3RL, VLK, JVT, YV2RC, YV3RC, and also many locals and Canadians have been heard and a number of unidentified stations, too. Code transmitters do plenty of damage to my reception. A Javanese station on 49 meters is heard mornings. LKJ1 on 31.4 meters has been heard mornings also. Reception has not been as good as expected—the static level has been rather high on all bands most of the time. I am experimenting with a new aerial, then perhaps reception will be as of old.

A veri from 3LR has been received. It is a cream-colored card with black letters. 3RL Veris have been very slow in coming in for some reason or other. Here are the music and words of the Copenhagen City Hall Bells you hear from OXY. The watchman's song is heard 6 p.m. E.S.T. from OXY after full hour and bell of 12 strokes.

Musical score for 'BELL' and 'WATCHMAN'S SONG'. The score is in 2/4 time and includes lyrics in Danish. The lyrics for 'BELL' are: 'VAR-KLOG OG SNILD, VOGTLYS OG HLD'. The lyrics for 'WATCHMAN'S SONG' are: 'DAGEN GÅR MED - BASKE - FJED; DAGENS BØRN - MAA - RE - AFTENBROEN'. The score is divided into sections for 1/4 HOUR, 1/2 HOUR, 3/4 HOUR, FULL HOUR, and WATCHMAN'S SONG.

Official Listening Post Report of Geo. D. Sallade, Sinking Spring, Pa.

● THE outstanding feature of this month's radio reception was the inauguration of several new Italian broadcasting stations. The new stations heard at this post were IRS on approximately 8110 kc. and IRO on 9780 kc. Just what schedules these stations adhere to, is at present unknown; however, it is definitely known that IRS broadcasts an Italian-American program each Friday evening at 5:30 or 6:30 p.m., E.S.T. IRO is frequently on the air at 5 p.m. E.S.T. Another station, which probably will be heard shortly, is IRF. Reception of these stations is exceedingly fine and must be heard to be appreciated. All stations operated by "Italo Radio." Address E.I.A.R., via Montello, 5, Roma, Italy.

The following may be helpful in identifying these stations: (1) There are no station announcements between selections. (2) Announcements which are made about every 15 minutes are similar to this. "Hello, Hello, America. This is Italo Radio calling you. IRA, Italo Radio, Rome. Hello, Hello America. Italo Radio calling you."

Another station which has been heard quite frequently is COH, in Havana, Cuba. The best time for reception of this station is about 5 p.m., E.S.T. The wavelength is 31.8 meters or 9428 kc. They verify promptly with a nice QSL card. Address: Calle B, No. 2, Havana, Cuba.

RV59 can be heard about 5 pm. almost daily. Careful tuning on the low frequency side of COC will bring in this one.

Another new experimental station is DJN. This station is used quite frequently about 5:30 p.m. in the German, broadcast to Central and South America.

Recent verifications include VK3LR and TIEP. The QSL card of 3LR states that only 600 watts is used, with uni- and omni-directional antennae.

Short Wave SCOUT NEWS

O.L.P. REPORT

From Frank Hogler, Brooklyn, N.Y.

● RECEPTION here in November has been good, especially for the South American stations. The Australians came over fine—that goes for VK2ME, VK3ME, and VK3LR, all on 31 meters; for best results, tune from 4 a.m. to 7 a.m. E.S.T.

The Japanese stations can be heard, but are a little weak in signal strength. JYS on 30.49 meters comes over fairly well,

OLIVER AMLIE, WELL-KNOWN S.W. FAN, PROUD OF HIS TROPHY



The winner of the tenth SHORT WAVE SCOUT Trophy was Oliver Amlie of Philadelphia, Pa., who is here shown with his trophy. Mr. Amlie has exhibited his trophy in a number of public places, including store windows, and he has gained a lot of Good Will for SHORT WAVE CRAFT by so displaying it—for which the editors sincerely thank him. Mr. Amlie is the originator of the famous DX-er Circuit bearing his name; he is now busy with new short-wave coil improvements.

but irregularly. JYR on 38.07 meters can also be heard, but only when receiving conditions are favorable—4-7 a.m. E.S.T. JVM on 27 meters has not been heard here lately, but a station broadcasting on 44 meters is received practically every morning; they have part of the program broadcast by JVM on 27 meters. This same pro-

Latest "Hot" Tips for Short-Wave Listeners from our "OFFICIAL LISTENING POSTS"

gram is heard from 6 a.m. to 6:15 a.m. E.S.T. It consists of oriental music which sounds like bells, whistles, and drums. It may be that JVM is now broadcasting on 44 meters.

Try tuning on 49 meters from 4 to 7 a.m. E.S.T. a few mornings straight. You will find a good catch—station ZTJ, sometimes called JB, Johannesburg, South Africa, coming in nicely but this is only when receiving conditions are fair.

IRM on 30 meters has been heard quite often here. The signal is very good. Tune from 4:30 p.m. on; it is sometimes heard up to 7 p.m. E.S.T.

Station COH on about 31.50 meters comes in with a "bang." According to the announcement over the air, this station should be addressed as follows: 2 B Street, Havana, Cuba. The best time to tune this station is 5 p.m.

Station RNE should not be missed; it comes over extraordinarily good. To reach this station you should address your letters to Radio Center, Moscow, U.S.S.R. It is best heard on Sundays from 6 a.m. on up to 11 a.m. E.S.T. Try tuning this station at different hours, say 8 a.m.-9 a.m., for best results.

TIX on 51 meters, San Jose, Costa Rica, comes in good. They use gongs and a siren as an identification signal, also "La Reina Del Aire." Time to tune—7 to 10 p.m., E.S.T.

Herman Borchers Reports

● RECEPTION on the short waves during November was excellent on the 49- and 19-meter band. The 31-meter band was fair, but 25 meters was practically dead.

VK3LR came in good from 7-8 a.m. R7; VK3ME received fair, plenty of static. R1; VK2ME was very strong from 6-8 a.m. R8.

PHI was not heard at all, but their sister station PCJ, on 19 meters, came in like a "local" station from 8-11:30 a.m. R9 plus. DJB on 19.73 meters is still the "out-standing" station on this band; have heard it every day. R9.

CNR, Morocco, and RNE, Moscow, were very poor. R3.

The South American station, with the exception of PRF5 were full of static and there was no fun in listening to them at all.

COH on 31.8 meters or 9428 kc. is a new station and according to their verification, which I just received, is on the air from 8-10 p.m., reception R8. This station wants report. The address is: Calle B, No. 2, Havana, Cuba.

COC, Cuba, is on the air daily from 9:30-11 a.m. and 4-6 p.m. and Saturdays from 11 p.m. to 1 a.m.

IRS, 36 meters, Rome, was broadcasting every Friday from 5-7 p.m. Reception of this station was R6.

IRA, 49.2 meters, Rome, is also a new station. This station is broadcasting every Monday, Wednesday, and Friday from 6 to 7:30 p.m. Reception was R9. Announcements of this station are made in English, this station wants reports.

DJN on 31.45 meters is a new German station, it is on the air every day from 9 to 10:30 p.m., broadcasting the same program as DJC, 49.80 meters, during the month of November, and asks for reports also.

A letter from W1XAL, Boston, stated that this station is going to be on a regular schedule as follows: Sundays, Tuesdays, and Thursdays from 7:30 p.m. to 10:30 p.m. or later, starting Sunday, Dec. 2.

Report from Oliver Amlie, Philadelphia, Pa.

● OCTOBER 25, 1934, was the first time this post went on the air since April 1934. when a second attempt was made for the SHORT WAVE SCOUT Trophy. Ever since Oct. 25, this post has been doing more than fine on the Australian zone. Here are the Australian stations heard for November 1934. Sydney, VK2ME 31.28 meters. 5:30-8:30 a.m. Melbourne, VK3ME, 31.31 meters, Wednesday and Saturday 5-7:30 a.m., and 8 a.m.; Sunday and Monday, 6:45-7 a.m. Victoria, Australia, VK3LR, 31.31

(Continued on page 621)

SHORT WAVE SCOUTS

12TH "TROPHY" WINNER
Edward G. Schmeichel, 2939
South Loomis St., Chicago, Ill.

170 Stations; 85 Verified

● WE take pleasure in awarding this month's "Trophy Cup" to Mr. E. Schmeichel of Chicago, Ill., who submitted a very fine list of stations, having a total of 170 with 85 verifications ("Veris").

The receiver used was a National model "SW 45" receiver, ahead of which was connected a 2-stage "Postal" Booster (pre-amplifier). The antenna was a Lynch "doublet," 41 feet long (15 ft. above roof of house) with transposed lead-in. The list of stations were "logged" over a 30-day period from Aug. 14 to Sept. 13, 1934.

The list of stations submitted in this contest may be for any particular 30-day period. Keep your list of stations until you have obtained a large number of veris which should be at least 50 per cent of the entire list submitted. Warning: This month we had a very sad experience. One of the contestants had a very imposing list of stations and would probably have won the cup, except for the fact that there was evidence of "cheating." It could be plainly seen on a good many of the verification cards that the dates had been "changed." *This disqualified him!*

Beginning with the April issue of SHORT WAVE CRAFT, a NEW set of rules will be put in effect. Complete details will be printed in the next issue and some of the following points will be incorporated. The Trophy will go to the person having the greatest number of "veris"; unverified lists will not be required and 50 per cent of his "veris" must be for stations outside of the country in which he is located. Also, only "veris" stating specifically that reception is verified will be counted. In other words, Daventry stations will not be counted, because they do not verify, nor will any of the commercial radio-telephone stations, unless—for some reason or other—they send you a specific verification.

LIST OF VERIFIED STATIONS

GSA—London, England—49.50 meters—"This is London calling"—heard nightly.
 GSB—London, England—31.25 meters—"This is London calling"—heard afternoons.
 GSC—London, England—31.3 meters—"This is London calling"—heard evenings.
 GSD—London, England—25.5 meters—"This is London calling"—replaced by GSA.
 GSE—London, England—25.2 meters—"This is London calling"—heard in afternoon.
 GSF—London, England—19.7 meters—"This is London calling"—heard in morning.
 GSG—London, England—16.86 meters—"This is London calling"—early mornings.
 GSH—London, England—13.96 meters—"This is London calling"—early mornings.
 Radio Coloniale—19.68 meters—"Ici Paree Radio Coloniale"—mornings.
 Radio Coloniale—25.63 meters—"Ici Paree Radio Coloniale"—evenings.
 Radio Coloniale—Paris, France—25.20 meters—"Ici Radio Coloniale Paree".
 EAQ—Madrid, Spain—30.40 meters—"Radio Es-

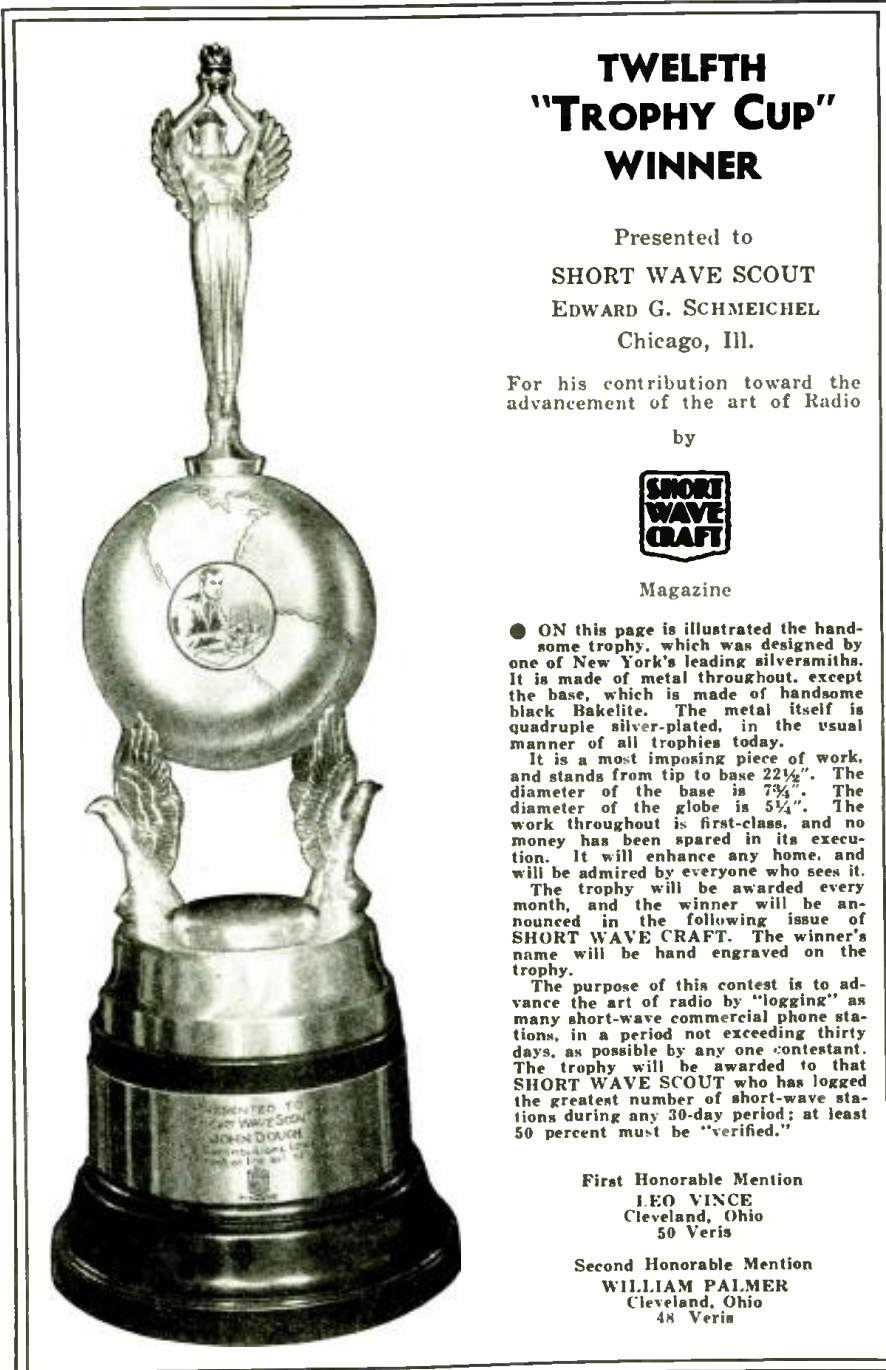

TWELFTH "TROPHY CUP" WINNER

Presented to
SHORT WAVE SCOUT
EDWARD G. SCHMEICHEL
 Chicago, Ill.

For his contribution toward the advancement of the art of Radio



Magazine

● ON this page is illustrated the handsome trophy, which was designed by one of New York's leading silversmiths. It is made of metal throughout, except the base, which is made of handsome black Bakelite. The metal itself is quadruple silver-plated, in the usual manner of all trophies today.

It is a most imposing piece of work, and stands from tip to base 22 1/2". The diameter of the base is 7 3/4". The diameter of the globe is 5 1/4". The work throughout is first-class, and no money has been spared in its execution. It will enhance any home, and will be admired by everyone who sees it.

The trophy will be awarded every month, and the winner will be announced in the following issue of SHORT WAVE CRAFT. The winner's name will be hand engraved on the trophy.

The purpose of this contest is to advance the art of radio by "logging" as many short-wave commercial phone stations, in a period not exceeding thirty days, as possible by any one contestant. The trophy will be awarded to that SHORT WAVE SCOUT who has logged the greatest number of short-wave stations during any 30-day period; at least 50 percent must be "verified."

First Honorable Mention
LEO VINCE
 Cleveland, Ohio
 50 Veris

Second Honorable Mention
WILLIAM PALMER
 Cleveland, Ohio
 48 Veris

spanisho Madrid"—5:30-7 p.m. E.S.T.
 CT1AA—Lisbon, Portugal—31.25 meters—Three cuckoo calls—Tues and Friday, 6 p.m.
 ORK—Russede, Belgium—29.04 meters—"Here is Brussels"—1:45-3:15 p.m.
 PHI—Hilversum, Holland—16.88 meters—Announcements in English—now on 25.5 meter.
 GCW—Rugby, England—30.60 meters—Transatlantic phone—heard regularly at 6 p.m.
 GCU—Rugby, England—30.15 meters—Transatlantic phone—heard regularly at 6 p.m.
 GCS—Rugby, England—33.26 meters—Transatlantic phone—heard irregularly.
 GBU—Rugby, England—24.41 meters—Transatlantic phone—heard irregularly.
 HBL—Geneva, Switzerland—31.27 meters—News—in English—Saturday, 5:30-6:15 p.m.
 HBP—Geneva, Switzerland—38.47 meters—news in English—Saturday 5:30-6:15 p.m.
 LSN—Buenos Aires, Argentina—30.30 meters—phone to America—irregularly, evenings.
 LSX—Buenos Aires, Argentina—28.98 meters—used with KFZ—regularly evenings.
 PSK—Rio de Janeiro, Brazil—36.65 meters—phoning in evenings—uses music.
 HC2RL—Guayaquil, Ecuador—45.00 meters—"Hello America"—Tuesday and Sunday evenings.

HJ5ABD—Cali, Colombia—46.30 meters—"La voz del Valle"—heard in evenings.
 YV3RC—Caracas, Venezuela—48.78 meters—announces English—5-11 p.m. daily.
 HJB—Bogota, Colombia—20.36 meters—phoning with Florida—daily at 10 a.m.
 PRADO—Riobamba, Ecuador—45.31 meters—"Radio Station Prado"—Thurs. 10:30-11:30 p.m.
 PRADO—Riobamba, Ecuador—19.55 meters—"Radio Station Prado"—Sunday 5-6 p.m.
 HCJB—Quito, Ecuador—73 meters—announces in English and Spanish—daily 7:30-9:45 p.m.
 W2XAF—Schenectady, N.Y.—31.48 meters—relays WGY—evenings 7:00-10 p.m.
 W2XE—New York City—19.64 meters—Columbia Broadcasting System—heard mornings.
 W2XE—New York City—25.36 meters—Columbia Broadcasting System—heard afternoons.
 W2XE—New York City—49.02 meters—Columbia Broadcasting System—heard evenings.
 W3XAL—Boundbrook, N.J.—16.87 meters—National Broadcasting Co.—heard mornings.
 W3XAL—Boundbrook, N.J.—49.18 meters—National Broadcasting Co.—heard in evenings.
 W3XAU—Philadelphia, Pa.—49.50 meters—re-
 (Continued on page 619)

SHORT WAVES and

A Sailor's Idea of a Ham Station



This amateur transmitting and receiving station is owned by H. E. Gibson and is operated under the Ham ticket—W5DSI. The main circuits of the transmitter and receiver were taken from back numbers of SHORT-WAVE CRAFT.

Editor, SHORT WAVE CRAFT:
99-101 Hudson St.,
New York, N.Y.

Here's a photo of myself and my licensed short-wave station, W5DSI.

The transmitter consists of a 247 crystal oscillator, a 246 doubler stage and a 210 final amplifier, with 600 volts D.C. on all stages using two power packs with 283 rectifiers. The transmitter consists of two sections: The power supplies in the lower part with appropriate switches in front for A.C. line, oscillator-doubler and final amplifier plate circuits; the upper part consists of the radio frequency part with tuning dials and meters on the panel.

The receiver consists of tuned antenna, tuned R.F. using a 258, a 257 electron-coupled detector, a 256 transformer coupled audio stage for phones, and a 247 output stage for dynamic speaker. Voltage is furnished by a power pack using a 280 tube for rectifier.

The main circuits of both the transmitter and receiver were taken from SHORT WAVE CRAFT. The oscillator was taken from an article by Mr. Stuart, the doubler and amplifier were taken from other circuits printed in your magazine. The receiver is a 4-tube Doerle revamped to fit the parts I had on hand.

The A.C. monitor is behind my left arm. Below and in front are switches for switching from receiver to monitor and from phones to speaker. Next comes the receiver, speaker, "bug," and transmitter. Line switch and fuses are on the wall above the transmitter and A.C. line meter

above the switch (not showing in photo). Receiver power pack is under table.

I think your "mag." is fine and don't miss a copy. Sent in an application to join your SHORT WAVE LEAGUE last year. Am a first-class operator in the U.S. Navy and have been in radio for 14 years. Am also chief operator of the Galveston Amateur Radio Club transmitting station, W5DIG.

With the outfit shown in the photo, have worked Australia, New Zealand, Tasmania, Hawaii, Cuba, Mexico, Canada, and all districts of the United States. The whole station was constructed by myself.

I agree with Mr. Hallock in his letter in your August issue about "Bloopers." An R.F. stage will eliminate this and also a tuned R.F. stage adds greatly to the selectivity and is very helpful in code reception.

I have a heavy "loose-leaf" binder in which I have placed every transmitting and receiving circuit published by you in the last year and a half. It has proved to be a great help in construction and have settled many arguments among the local short-wave "fans" by getting out "The Book."

H. E. GIBSON, U.S.N., W5DSI,
U.S. Naval Radio Station,
Galveston, Texas.

(Dandy work "H.E.G."—and we think your idea of collecting all the diagrams in a "scrapbook" a capital one, and our readers will undoubtedly find it worth putting into practice.—Editor)

BUILT MANY "SWC" SETS OK!

Editor, SHORT WAVE CRAFT:

I am a member of the Short Wave League and a constant reader of SHORT WAVE CRAFT. I have been reading it for over two years and can truthfully say that it is the best short-wave magazine on the market. I have built many of the receivers described in SHORT WAVE CRAFT and they have all worked "FB."

GLENN PRAHL,
Jasper, Ala.

(Thanks for your letter, Glenn, and we are "tickled pink" to know that you have built many of the receiving sets described in SHORT WAVE CRAFT, and that they worked "FB" (fine business).—Editor)

ALL THE WAY FROM FRANCE

Editor, SHORT WAVE CRAFT:

For many years I have been reading with great interest your fine SHORT WAVE CRAFT and I am very glad to tell you that all the results I obtained with my station F8DC were due to reading your magazine.

In France, we have also a small "Revue" devoted to "amateur radio," which is called "Journal des 8" and sometimes I have described in this magazine some transmitters or receivers I had built from the SHORT WAVE CRAFT articles. Many of my French friends are greatly interested and want to try these American novelties. I have thought that it would be interesting for all the French amateurs to read more upon American radio. Thus, I will ask you (if it

is possible) to put in your magazine a short notice in order to ask our American friends if someone would be so kind as to send me some articles upon their sets and also some descriptions of their stations (transmitter and receiver). I should be very pleased to translate them into French and to publish them in our newspaper "Journal des 8."

Besides it would be very interesting for we French amateurs to receive from the American "Hams" the list of the French calls heard in the U.S.A. Naturally if it may be of some use to you the list of the W's heard in France will be sent to you by myself. This small notice could for example be entitled "CQ de F8DC to all the American Hams" and if you can publish it, please give my address, which is:

LIEUTENANT OEHMICHEN, F8DC
Quartier Henri IV,
Fontainebleau, France.

(We are quite sure, Lieutenant, that you will hear from many American readers of this magazine who will be glad to give you brief descriptions of their stations or "pet" receivers and transmitters. Those among us who read French will undoubtedly be glad to subscribe to your publication—JOURNAL DES 8.—Editor)

HOT-CHA! FOR THE "19 TWIN-PLEX!"

Editor, SHORT WAVE CRAFT:

Recently I built the 19 Twinplex, described in the March, 1934 issue of SHORT WAVE CRAFT. In a poor location on the ground floor of an 18-story building with a loosely strung aerial, I have received the following stations with only three nights of listening: DJC, DJD, Germany; GSB, GSC, GSD, England; FYA in France; W2XE, W8XAL, W9XF, W2XAF, and W8XK on two bands.

ALBERT RAE,
457 W. 57 St.,
New York City.

(Hotcha! Albert, and you have certainly stepped out with the "19 Twinplex." We have had many excellent letters from our readers who have built the "19 Twinplex." In view of the fact that you are located in a steel frame building, which always tends to absorb a great deal of energy from short-wave signals, we congratulate you on the fine success and "transoceanic reception" you have accomplished with the 19 Twinplex.—Editor)

FINE RESULTS WITH STANDARD "ALL-WAVE" RECEIVER

Editor, SHORT WAVE CRAFT:

For the interest of others working with short waves, here is a list of stations received on my Philco receiver: W8XAL, Ohio; VE9GW, Canada; EAQ, Spain; DJA, Germany; GSC, England; HJ1ABB, South America; DJB, Germany; W3XAU, Philadelphia, Pa.; GSB, England; W9XF, Chicago; LSX, Buenos Aires; HC2RL, South America; GSA, England; GSE, England; YV3BC, South America; HILA, West Indies; GSD, England; W8XK, Pittsburgh; XEB, Mexico; HJ3ABF, South America; PRA3, Brazil; HCK, South America; EAQ, Spain; CJRX, Canada; PHI, Holland; FYA, France; J1AA, Japan; DJD, Germany; VK3ME, Australia.

SAMUEL D. SLIDER,
28 S. 4th Ave.,
Coatesville, Pa.

(Great results, Samuel, with your Philco and Pilot "Super Wasp" sets.—Editor)

One Year's Subscription to
SHORT WAVE CRAFT
FREE

for the "Best" Station Photo

Closing date for each contest—60 days preceding date of issue: Jan. 1 for March issue, etc. The editors will act as judges and their opinions will be final. In the event of a tie a subscription will be given to each contestant so tying.

LONG RAVES • • • OUR READERS' FORUM

"OSCILLODYNE" SET HITS HIM RIGHT

Editor, SHORT WAVE CRAFT:

In your April, 1933 SHORT WAVE CRAFT magazine the 1-tube *Oscillodyne* was published which got me interested in SHORT WAVE CRAFT and short-wave radio. I never did see such a receiver as that was! I kept it for about three months and constructed another receiver and have built a good many sets from your magazine. One was Mr. Wyeth's *all-wave* receiver which was a "dandy," but I have now built a receiver using the Leotone circuit, only I changed it to suit myself. I have had very good results with it, as the German, English, and South American stations come in like "nobody's business." I am using the A.C. circuit using a 58 R.F., 57 detector, 56 audio and 2A5 as amplifier, running a 6" dynamic speaker. I am building a new set using the "Doerle" circuit—The latest A.C.-5. I would like to hear from anyone else who would care to write. I am not a licensed "Ham" because of the code, but I think these fellows should forget the "No Code below 6 meter" question. What isn't worth working for, isn't worth having.

Keep up the good work!

LOWELL DITMER,
1260 Colwick Drive,
Dayton, Ohio.

(We are happy to know that you had such excellent success with the 1-tube *Oscillodyne* and also that Mr. Wyeth's description of his *all wave* receiver worked out so satisfactorily for you. Undoubtedly you will hear from many readers of SHORT WAVE CRAFT and we trust to hear from you again regarding the results you obtain with sets described in SHORT WAVE CRAFT. —Editor)

AN A-1 ENGLISH STATION

Editor, SHORT WAVE CRAFT:

Being a regular reader of your paper I am sending you enclosed photograph of my station, located in Scarborough, England. The transmitter is on the right being 100 watts. CO. FD. PA. rig just above is the antenna panel and feeders. To the left is the high voltage "keying" relay and bug, monitor and two-tube receiver O.V.I. My power supplies are under the transmitter in cupboards, which is 1000 volts R.A.C., 230 volts A.C. input and rectified by mercury vapor tubes. I use the 20.40 meter bands and use phone having worked W1B0 and received R7 report. I have made a goodly number of visits to New

Harry Berns Has Heard Every Country Many Times

"Prize-winning" station photo awarded One year's subscription to SHORT WAVE CRAFT.

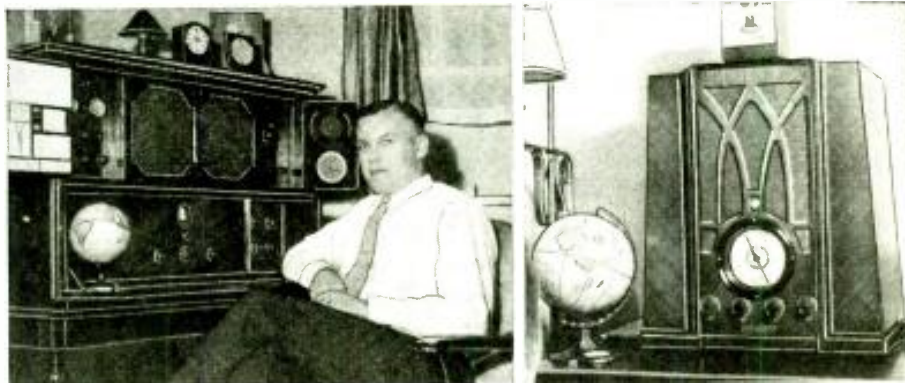

The prize this month goes to Harry Berns and he has a particularly efficient short-wave "listening" station. Not only does Harry listen on the short and broadcast waves, but he also has a first-class tuner going all the way up to 4,500 meters. He uses a Lynch transposition lead-in aerial system, comprising two 65-foot, four-wire cages for the flat-top.

Editor, SHORT WAVE CRAFT:

Herewith a few shots of my radio installations for your "best photo" contest. As the letterhead shows, I am an artist and naturally strive for balance and neatness in my radio outfits, as well as in my work. Although I have been listening and playing with short waves since 1926, you won't find any verification cards tacked up all over my walls. I started in 1926 with a 3-tube job and since then I have heard every continent and country many times. I've tried out practically every radio since, always looking for the best, regardless of what it costs. I finally have an outfit which I take great pride in and it sure gives results.

The larger photo shows my Scott receiver, 15 to 570 meters, in large walnut cabinet. All doors close, so that only main lower panel shows. Left-hand door has circuit diagram, selectivity, sensitivity and power output curves. Note SHORT WAVE LEAGUE button. Left-hand panel is control panel with A.C. and output meters, noise suppressor and output resistor knobs,

York during and after the war. I was a "sparks" (radio operator) at that time on S.S. *Vedie*, White Star Line, and radio has been with me since. I am also a member

(Continued on page 616)

phone jack, and switches. Right-hand panel is "long wave" tuner for 560 to 4,500 meters, with tuning guide and world time chart on the door.

Lower right panel has two knobs and switch controlling short-wave antenna tuner, with lowest switch for *beat oscillator*. In lower left panel, I am now installing a two 58 stage pre-selector.

The smaller photo shows 8-tube superhet (12 to 560 meters) in my studio. While not as good as the Scott outfit by far, it "rolls them in" and keeps me posted while working. Note another S.W.L. button just above the airplane dial. I use a Lynch transposed lead-in aerial system, 2-65 feet, four wire cages, and also a regular Scott aerial with transmission line.

HARRY F. BERNS,
511 New York Ave.,
Manitowoc, Wis.

(Nice work, Harry, and you certainly deserve credit for a neatly arranged S-W listening post de luxe. With your equipment and experience, why not try for the SHORT WAVE SCOUT Trophy Cup?—Editor)

AGAIN THE DOERLE WINS

Editor, SHORT WAVE CRAFT:

I have built radios for the past 15 years and have made some dandy broadcast receivers, but it has been just since January, 1932, that I have become interested in short-wave receivers and that was started by seeing the Doerle two tube receiver hook-up in the January issue of SHORT WAVE CRAFT.

I built the receiver and got very fine results, but since then I have added another audio stage and have got a list of stations that I am very proud of. Some of my best catches are—FAQ, Madrid, Spain; LSX, Buenos Aires, Arg.; VE9GW, Bowmanville, Ont.; PCK, Kootwijk, Holland; KNRA, Seth Parker; DJA, Berlin, Germany; CTIAA, Lisbon, Portugal; W10XEA, Schooner Morrissey; COC, Havana, Cuba; YV3BC, Venezuela, S. A.; PRF5, Rio De Janeiro, Brazil.

I have bought every issue of SHORT WAVE CRAFT since January, 1932, and would not take twice the amount of money paid for them and be without them. So hope you keep up the good work "forever!"

Let's see more amateur transmitting hookups as I hope to be an amateur in the near future.

RICHARD W. HERRON,
1222 E. 12th St.,
Muncie, Ind.

(Well, the Doerle seems to be going mighty strong still, Richard, and it gives us great pleasure to know that you have heard so many "foreign" short-wave broadcasting stations on your "Doerle."—Editor)

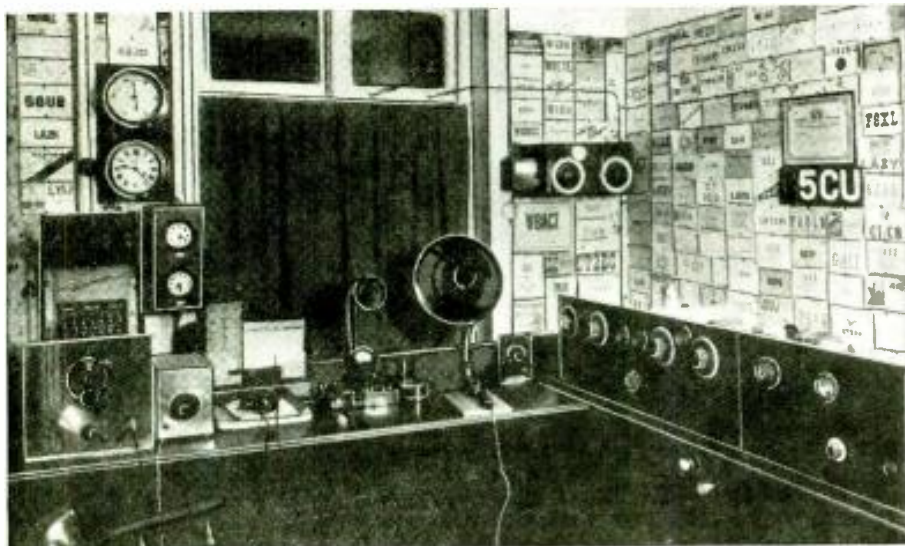

Here's a dandy British "Ham" station owned and operated by Jack Cuthbertson, G5CU, which is operated at Scarborough, Yorkshire, England. This station is a member of the British Navy "Net."

"TIN-CAN" 4-Tube Set

By ELWYN S. BRYANT, E.E., A.I.E.E., I.R.E.

Efficient 4-tube battery-operated receiver; extremely simple to build; it should appeal to our readers who have a "yen" for battery receivers. The entire receiver is housed in a revamped "oil can."

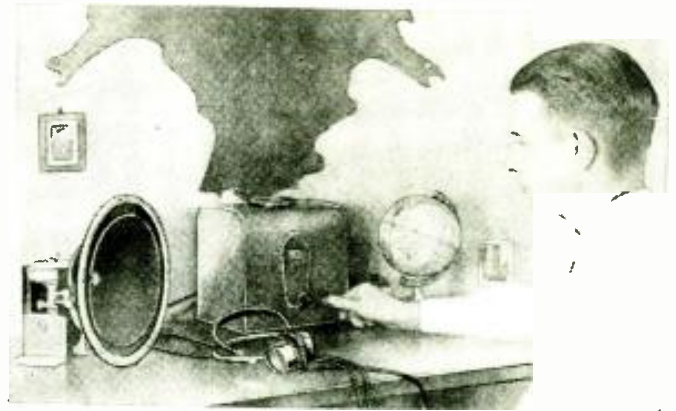

The author, Mr. Bryant, tuning the "Tin-Can" 4-tube set



The author busy constructing the cabinet from a discarded oil can.

● HERE is a short-wave radio that any one can afford. It is built of discarded radio parts and is housed in a cabinet built from a 2-gallon oil can! It boasts of four tubes, an untuned screen-grid radio frequency stage, a screen-grid regenerative detector and two stages of audio. The last audio tube is a pentode. This line-up of tubes gives us a set that is small in size and cost, but large in performance. It will give loud-speaker performance on all but the weakest stations, which is very good considering there is only one tuned stage, but the tuning is very sharp. Even in the broadcast bands, a degree or so on the dial will tune out a station.

To those that have never used a completely shielded short-wave set, the operation of this set is a revelation. There is absolutely no "hand effect." That is, the movement of a person's hand, near the control, has no effect on the tuning. The set is quiet in operation and slides into oscillation with a slight hiss without effecting the tuning. Because of the untuned radio frequency stage, there are no "dead-spots" anywhere on the dial due to antenna resonance.

The construction of the cabinet comes first. With a blow-torch or gas flame, melt off the handle and pouring spout from your 2-gallon oil container. Lay the can on its side and by means of a short length of board, scribe a line, just above the turn of the side, all the way around. Cut just below this line with a can opener and finish to the line with tin shears.

The radio frequency coil shield is mounted in a hole cut in the exact center of the cabinet top. This hole is best cut with a circle cutter. The shield, itself is a Cocoamalt or small size coffee can. It is soldered in place from the inside of the cabinet, so that the edge of the lid just touches the cabinet. I will remind those questioning the use of a magnetic material, such as a tin can for a radio frequency coil shield, that the use of regeneration overcomes effective resistance. Any slight loss caused by the use of a shield, around the coil, is offset by the increased quietness of operation.

Hints on General Layout

I am not going to give any dimensions for laying out the equipment inside the cabinet, because every builder will have his own parts and will have to lay out his own dimensions to fit these parts. I am only showing a general layout of the necessary parts and strongly recommend that this layout be closely followed, because it gives exceptionally short radio frequency leads and easy wiring. One change that I would suggest, is the use of a 7-prong tube socket or cable connector, in place of the 5-prong one that the writer used.

This would allow the C-battery leads to be brought up in the cable and would eliminate three binding posts on the back of the set.

Now to put the finishing touches on the cabinet. The hollow section of a small curtain rod is opened a trifle on the seam and fitted around the bottom of the cabinet. The corners should be carefully mitered together and soldered. The rods are soldered to the can on the inside. This construction covers up the sharp edges and stiffens the whole can. It improves the appearance very much.

Paint the cabinet with a quick-drying enamel and place in the oven under low heat to bake. Baking gives a hard, glossy finish that looks like a manufactured article. The original set was painted dark green, although brown or black would look very well. Perhaps you have some color scheme of your own that you would prefer. Whatever you use be sure to try it on an old tin can first. Do not get the oven too hot or you will melt the solder out of the cabinet.

Winding the "Plug-In" Coils

While the cabinet is baking, wind your coils. (Continued on page 630)

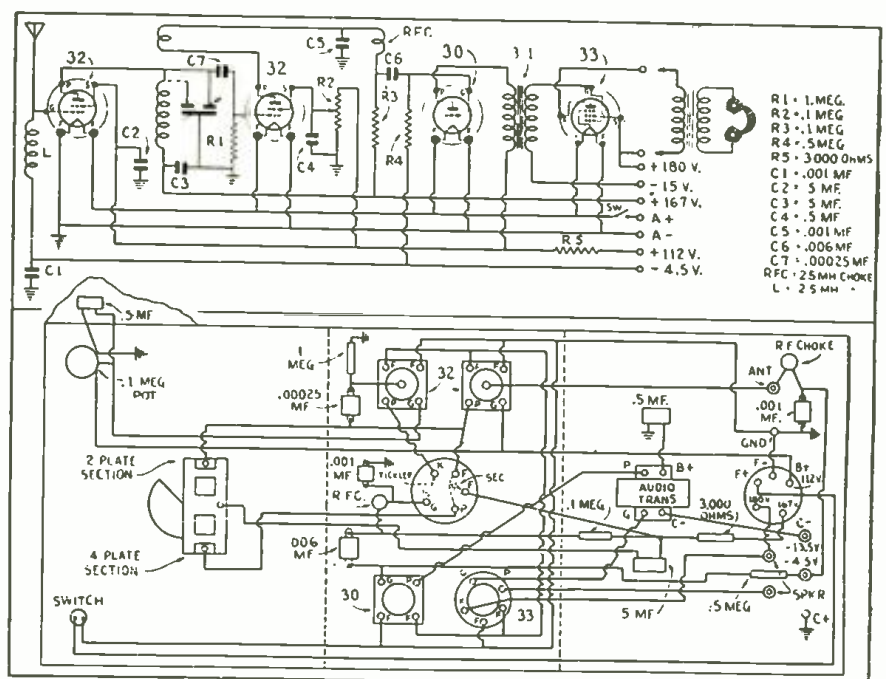

Wiring diagrams for novel 4-tube, battery-operated, short-wave receiver.

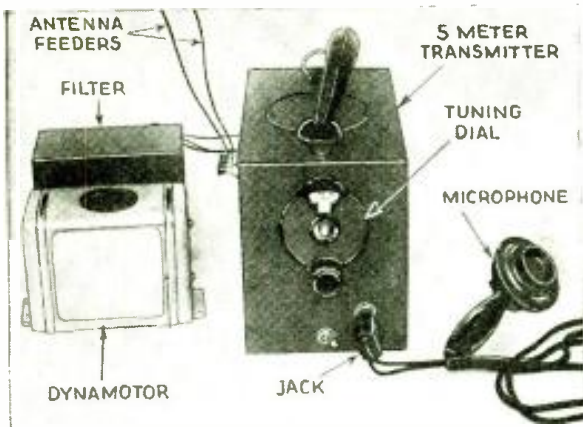

Here is the complete "portable" set-up with the exception of the storage battery.

● SINCE the 5-meter amateur band has been opened to the "ham" for mobile operation, many of the amateurs have installed portable transmitters in their cars and are obtaining excellent results. Many of them have covered fairly long distances, considering the very low power of the average portable transmitter. The now popular transceivers can be heard on the 5-meter band, in and around New York City, any evening. The object is to find a location that has considerable elevation, set up the portable "gear" and work as many fellow "hams" as possible.

The outfit shown in the photographs is not a transceiver but a complete transmitter intended as a companion unit to the compact receiver described in the November issue of SHORT-WAVE CRAFT. These two sets provide the operator with a complete installation with which "duplex" can be worked with ease. This is quite an advantage over the popular transceiver, with which it is impossible to work duplex. Duplex operation is one of the main advantages of ultra short-wave communication and we see no reason why it should not be a feature of the "portable rigs." We will agree though that the transceiver is more simple to construct.

Uses Dynamotor for Plate Supply

When a transmitter is operated in a car or from a portable location where there is no electric power available the machine must be battery operated. The best arrangement is to use a motor-generator similar to those used in car radios intended for broadcast reception. These little "dynamotors" run by power taken from a 6-volt storage battery and the generator portion delivers around 250 volts at 50 to 60 milliamperes. This is ideal for the fellow who wants efficient and economical operation of his portable. Such a generator system is used with this portable and the photograph shows how compact the affair really is.

New 6A6 Tube Employed

The hardest part of building a portable transmitter is the selection of tubes. We started out to use a type 19 twin-triode with a filament resistor to drop the voltage to two volts. Fortunately, just before the set was completed, the tube manufacturers came out with a type 6A6; this tube is identical to the type 53 with the exception of the heater, which requires 6.3 volts instead of 2.5 as in the 53. This tube is just what we needed. Of course we

5-Meter Mobile XMITTER

Uses "Dynamotor"



We take pleasure in presenting this very compact and highly efficient "portable" transmitter designed to be used in an automobile. Only two tubes are used, a 6A6, push-pull oscillator, and a 42 modulator. A distance of 18 miles was covered by this transmitter during tests. It operates from a 6-volt car storage battery and a small dynamotor is used for the plate supply.

cannot operate the 6A6 at full input in a "portable rig," because the problem of obtaining full modulation becomes more complicated and requires too much equipment to make the thing practical and economical.

Consulting our Tube Manual, we

find that the type 42 is the most advisable modulator to use where a single tube is used. Here is quite a problem; the 42, if operated under conditions advised by the manufacturers, will not

(Continued on page 625)

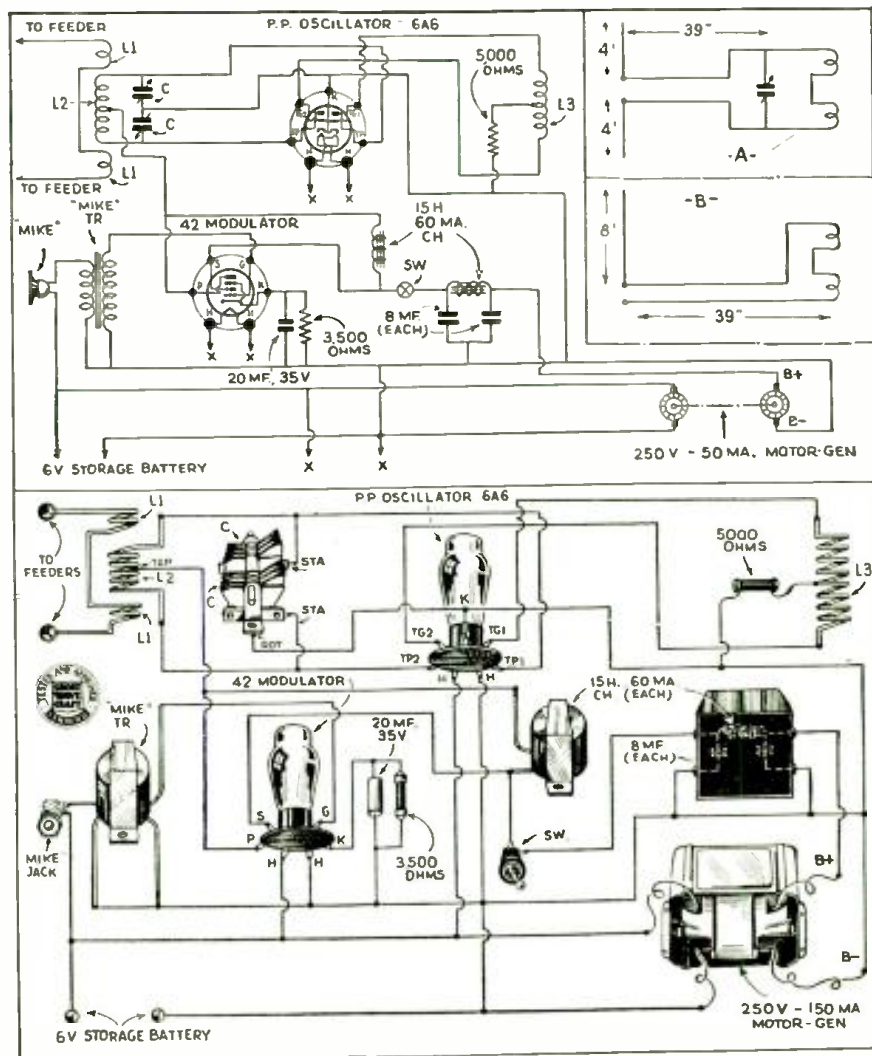

Schematic and physical drawings, clearly showing values of parts and connections for the 5-meter "mobile" transmitter.

WHAT'S NEW

The short-wave apparatus here shown has been carefully selected for description by the editors after a rigid investigation of its merits

In Short-Wave Apparatus

16-Tube's Range 9 to 2400 Meters!

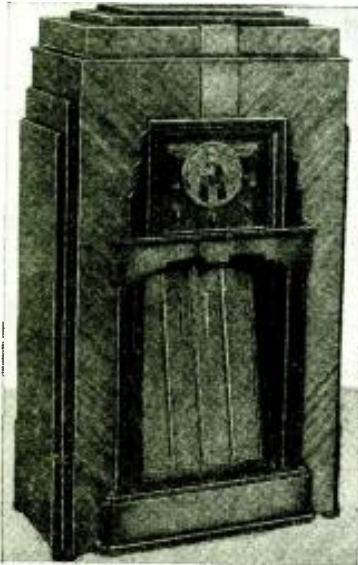

Handsome appearance of the newest model 16-tube Midwest receiver, with a range of 9 to 2400 meters.

● THE editors recently experienced a thrill in putting the new Midwest 16-tube receiver through its paces. One might well ask why a receiver should have a range of 9 to 2400 meters, or 33 megacycles to 125 kc. The reason why a lower range down to 9 meters is useful, is because of the fact that the wave lengths in commercial and experimental use are slowly but surely progressing downward. For instance, while tuning on the higher frequencies, or lower wave lengths, the new police transmitter in one of the cities near New York was picked up on 9.9 meters. One of the very fine new features of the Midwest is the accurately calibrated dial which has a cleverly designed "window" which makes it easy to read the wave length or frequency. Many European stations broadcast on wave lengths between 600 and 2400 meters; also airplane beacons, special experimental stations, government stations, etc.

and as the coil switch control is turned for the different bands, from 9 to 2,400 meters, the proper section of the dial is lighted up automatically, so that the tuning of the set and the selection of the desired wave band is made extremely simple. The loud-speaker is a large auditorium type and when fitted with the proper baffle handles the tremendous volume resulting from 16 tubes with extra fine quality. The tuning control is arranged with a special gear device so that the dial can be turned slow or fast, and this is very important where short-wave tuning is to be done with accuracy. The long range from 600 to 2,400 meters is desirable for the "real" radio fan, as a whole flock of stations in Europe broadcast on wave-lengths between 600 and 1,800 meters, some of these stations using hundreds of kilowatts. Therefore you have a very good chance of hearing them across the ocean with a set like this one, which is capable of tuning in these longer wave lengths. A novel tuning feature is the change in the strength of the dial light, which acts automatically as a resonance point indicator, the light becoming dimmer as the exact point of resonance is approached.

(Continued on page 632)

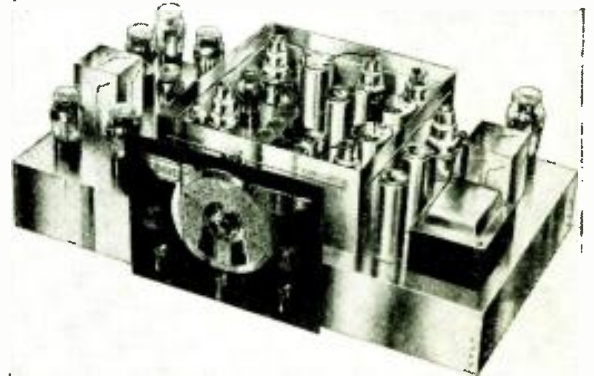

The well-designed 16-tube chassis of the new Midwest receiver. (No. 248).

The set showed tremendous power on all the different wave bands and unlike a great many "All Wave" receivers, it produced some of the finest "high fidelity" musical reproduction in the broadcast band (200 to 550 meters) that it has been our good fortune to listen to. The tone-controls on this set are calibrated so as to give high fidelity reproduction and the adjustment of tone throughout the treble and bass range is very complete and pleasing. The tone control on some receivers is one in name only.

One of the great secrets lying behind such a set as the new Midwest is the principle laid down by some of the foremost engineers, viz: that in order to get good quality and faithful reproduction with great volume, a sufficient number of tubes must be used to allow the signal to build up slowly or just a little in strength in each stage. If only a few tubes are used then they are all forced to do more amplifying of the signal than is desirable, and the resulting music or speech is quite likely to be distorted or strained when you hear it in the loud-speaker.

This set has the latest design of coils to cover the various wave bands

6-Tube All-Wave Superhet Uses Plug-In Coils

By J. de FRANCE, B.S., E.E.*

● THE "Martian Eagle" employs: 1-2A7 (detector oscillator), 2-58's (intermediate frequency amplifiers), 1-55 (half-wave detector and automatic volume control), 1-2A5 (power output), 1-80 (rectifier). A three-gang condenser is used in the broadcast band with preselection and two gangs are used on the short-wave bands. Since padding does not make the oscillator and detector stages track perfectly at all points due to the detuning action of

*Technical Advisor, Eagle Radio Co.

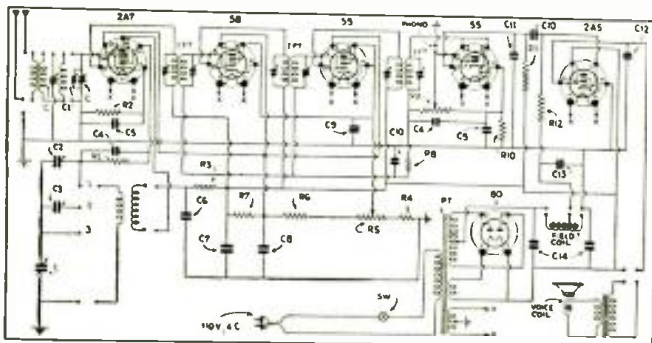
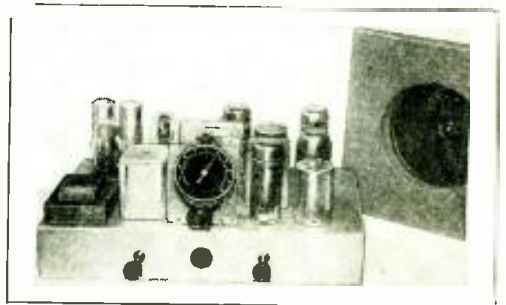

Diagram of the 6-tube All-Wave Superhet here described. (No. 249).

● Neatly laid out chassis of the 6-tube all wave "Martian Eagle."



the antenna, it was found necessary to use a small trimmer condenser in parallel with the detector condenser. Correct adjustment on this condenser is important as the detector stage is very selective.

The receiver employs a simple automatic volume control circuit and a manual sensitivity control. As the signal fades the automatic volume control increases the sensitivity of the receiver, holding the output constant. However, the noise level increases at the same time. This action continues with further fading until the receiver is working at maximum sensitivity. After that any further fading results in decreased output. Any attempts to hold the output by adding another stage to increase the sensitivity is futile because the external noise is now stronger than the signal and reception is too noisy. The manual sensitivity control can be adjusted to suit individual taste or local conditions. For example if the receiver is used for nearby reception (800 mile radius) the sensitivity (Continued on page 632)

Names and addresses of manufacturers of sets described on this and following pages furnished upon receipt of stamped envelope; mention No. of article.

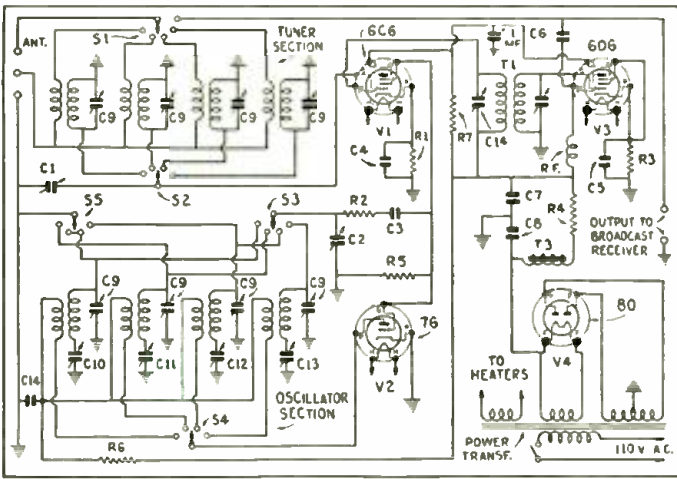

Diagram of new high-accuracy S-W converter

A 13-200 Meter Converter By HUBERT L. SHORTT*

solved that his converter would have none of them. The requirements as laid out in advance were as follows:

- 1—Full short-wave coverage, from 200 meters down to 13.
- 2—Reliable band switching.
- 3—Self-powered. This is important. The broadcast receiver certainly should not be expected to supply "juice" for three or four extra tubes; most low-priced B.C. sets just manage to stagger along by themselves! Good rectifying and filtering essential to keep hum level down.
- 4—Have adjustable I.F. coupling stage between mixer tube and receiver input, for the sake of selectivity and proper matching.
- 5—Strong mechanical construction.

By treating the converter as a deserving piece of apparatus, and not as a technical out-cast, the writer believes he has produced an acceptable instrument, one that really works and requires no apologies. The complete schematic diagram is shown here, and the con-
(Continued on page 615)



Appearance of latest "hand-switch" converter. (No. 256)

● IN talking with various radio people of his acquaintance, the writer has noticed that whenever the subject of short-wave converters is brought up someone always expresses his displeasure with these devices. "They're phooley," or some such other delicate expression, seems to sum up the general attitude.

Just why this is the case the writer was unable to understand until he was faced with the job of designing a converter himself and started looking over some of the available models. Without intending to disparage the ability of any fellow engineers, he was pained to observe that most of them were pretty weak and evidently had not received much preliminary thought. He made notes of their various deficiencies and then righteously re-

*Chief Engineer, Wholesale Radio Service Co., Inc.

"Speed Key" Designed by T. R. McElroy

● T. R. McELROY, the world's fastest radio telegrapher, was Official Champion of the World from 1922 to 1933. His official record was 56½ words a minute. Another record, which was authentic, but not a tournament speed was 73 words per minute! Truly a marvelous speed when one considers some of the automatic machines that are used to handle press don't go a whole lot faster than this. The average person would not be able to distinguish a dot from a dash at the terrific speed of 73 words a minute. From his years of experience, Mr. McElroy has designed a "semi-automatic" key embodying all the features that an experienced telegrapher would desire. We are showing this key with several of its outstanding features clearly indicated. This instrument has been designed so that it can be oper-

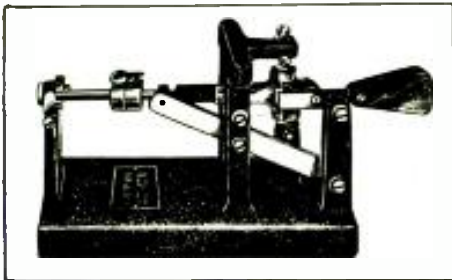

New "Speed" Key now available to "Hams." (No. 257).

ated either as a "straight" key or semi-automatic. The base and the structure are one piece of extra heavy cast material, making the instrument entirely rigid. This is a considerable aid in attaining perfect sending. All levers, etc., are set on two steel pinions between hardened pivot trunnions. The instrument is designed so that a speed ranging from 8 to 47 words per minute can be attained with perfect spacing and rhythm.

6-Tube All-Wave de Luxe Set

● THE new all-wave receiver shown in the photograph covers a range from 16 to 550 meters. It takes in all of the "popular" short-wave broadcasting bands, as well as the regular American broadcast band from 200 to 550 meters. Six tubes are used in all and the line-up is as follows: a 6D6 is used as a tuned radio frequency amplifier, a 6A7 pentagrid frequency converter, 6D6 I.F. amplifier, 75 second detector A.V.C. and first stage of audio and a 42 power amplifier pentode which feeds the large dynamic speaker, and an 80 rectifier. Among the many desirable features of this receiver is the special double shift dial arrangement wherein the ratio can be



Unusually handsome is this new "All-Wave" Set. The dial "hand" in use only is lighted. Tone quality extra good. (No. 258)

changed by simply raising or lowering the tuning knob, from a 10:1 ratio to an 80:1 ratio. Needless to say this 80:1 ratio when operated in the short-wave bands provides the effect of band-spread and tuning is not at all critical. Each wave band covered by the selector switch is separately illustrated on the tuning dial. The band in use is illuminated by the special selector switch. Reference to the photograph will reveal its extremely pleasing appearance,

which will provide the reader with a good idea of this handsome appearing and extremely well-designed superheterodyne receiver.

DX2 All-Wave Receiver By Irving Gordy*

● The All-Wave receiver described in this article should be of considerable interest to the short-wave "Fan" who, although quite limited in finances, still desires a compact, sensitive, efficient, and reliable short-wave receiver. When used properly, the circuit employed in this set is quite capable of producing excellent volume on "foreign" stations, and will even operate a magnetic loud-speaker on a few of the American stations.

Inspection of the circuit diagram reveals the use of a type 30 tube as regenerative detector which is resistance coupled to a type 33 power pentode audio frequency amplifier stage. Such a circuit,

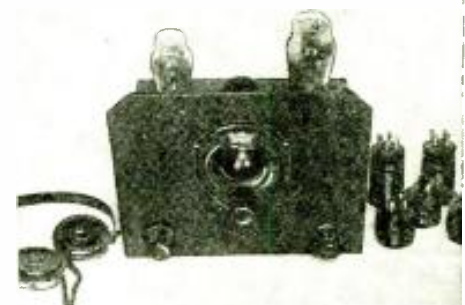

The "DX2" is a dandy "All-Wave" set for the "Beginner." (No. 259).

due mainly to the high power sensitivity of the 33 pentode, is quite capable of producing very good results.

The capacity C1 is the usual antenna series condenser. It should be adjustable
(Continued on page 617)

*Central Engineering Co.

5-Meter Transceiver "Kit"!

By BERNARD ERDE*



I.C.A. Transceiver in operation. (No. 253)

● THERE has been a mild boom in the ultra short waves during the past six months, and manufacturers of radio equipment have not been slow to appreciate it. They have flooded the market with "transceivers," but strangely enough practically all of these have been complete factory-built instruments. Transceiver kits have been conspicuous by their absence.

There are certainly thousands of radio fans interested in 5-meter work who would much rather build a set than buy an "assembled" unit, because they get as much fun out of building as they do out of using a piece of apparatus. In fact, there is one very numerous class of experimenters whose members are not happy unless they are either assembling or tearing down something—just for the sake of keeping

their minds occupied and their hands busy.

Amateurs who have been waiting for some concern to recognize their requirements in this regard will be interested in three new transceiver kits recently brought out by the Insuline Corporation of America. These kits are really complete, down to the last nut and soldering washer, and were designed with considerable care.

All three sets use the same strong steel cabinet, which is finished in beautiful and durable black crackle. They are the last word in compactness, for the box measures only 7 1/4 inches long, 6 inches high and 4 1/4 inches deep

*Engineering Department, Insuline Corp. of America.

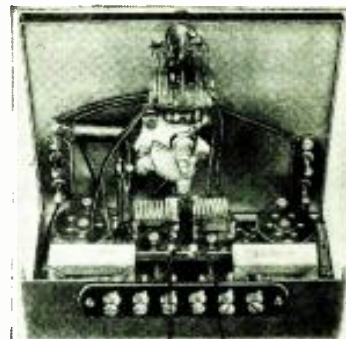

Rear view showing the neat arrangement of parts.

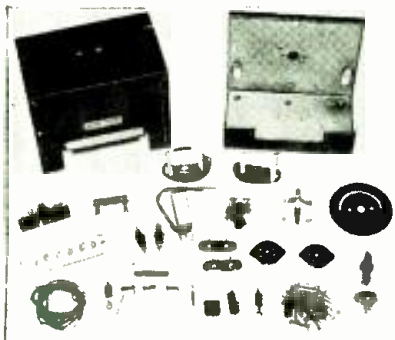

Complete kit of parts for 5 meter Transceiver.

and the completed outfits weigh only 4 pounds, less batteries. The 2-volt model, for operation on dry cells, uses a 30 and a 33. The 6-volt model, for storage battery use (particularly in a car) uses a 37 and a 41. The A.C. model also employs a 37 and a 41, but the circuit is a little different in that the audio tube is self-biased. Tubes of the 2A5
(Continued on page 623)

New Type of Molded Resistors



Here we have the new Lynch resistors undergoing "flash" test. (No. 254)

● THE new line of Lynch Resistors are made by an entirely new process, developed over the past six years as a result of intensive study of the different classes of resistors and research to eliminate the drawbacks of the general methods heretofore used. The new resistors are of the so-called carbon stick or composi-

tion type. It consists of a mixture of a very small percentage of conducting material, carbon, and an insulating material molded under relatively low pressures. Practically it really represents a number of semi-round pebbles which touch each other with point contact. Therefore, the paths and areas through which current may travel are reduced greatly by the large bulk of insulating particles, and this to a tremendous degree further by the point contact conditions.

The current density must be considered microscopically, and consequently has heretofore not been stressed to the extent its importance warrants.

A study of many micro-photographs bears this out. It shows that the structure of many competitive units (particularly carbon coated or film type) is not uniform and contains many voids, irregularities and inclusions. It is seen that the mass is not solid but porous and contact is point contact only. Therefore the current-carrying cross-section is microscopic, hence the current density must of necessity be very high at such points or areas.

This has been proved by studying under high-powered microscopes the action of the units under both normal and excessive loads. Glowing points of light were observed, proving the intense microscopic current density. Naturally, such points would tend to alter their characteristics both physically and mechanically.

Further study was made of resistance values



Checking for accuracy with precision equipment.

under mechanical loads, and the changes noted under such loads were to be expected in accordance with the above facts.

With these considerations in mind the Lynch Mfg. Co. engineers proceeded to develop a resistance, which technically and practically would overcome these objec-
(Continued on page 622)

New 5-Meter Beam Array Antenna

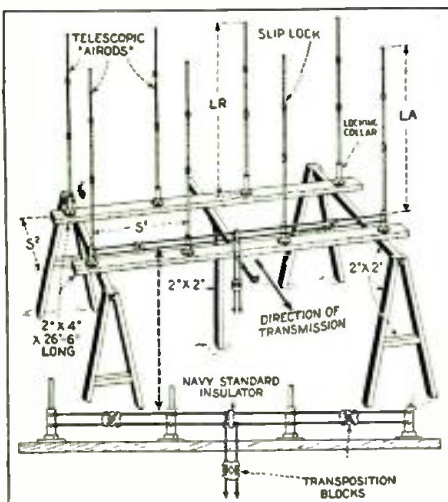

● THE new 5-meter beam array antenna being introduced by Arthur H. Lynch, Inc., comprises four telescopic antenna radiator rods and four small rods used for reflectors. As shown in the accompanying illustration, each radiator rod is provided with two binding posts, the upper post connecting directly to the rod and the lower post being dead.

By means of these eight rods and suitable framework, as indicated, an excellent 5-meter beam array can be erected in a very short time. Provision is made for the adjustment of the entire array at any

frequency between 56 and 60 megacycles. The dimensions LA, LR, S1 and S2 vary for the different frequencies employed. For instance, for 60 megacycles (5.0 meters) LA is 7 ft. 9 in., LR is 8 ft. 1/2 in., S1 is 8 ft. 2 1/2 in., S2 is 4 ft. 1 1/4 in. and for 56 megacycles (5.357 meters) LA is 8 ft. 4 in., LR 8 ft. 7 in., S1 8 ft. 9 in., S2 4 ft. 4 1/2 in. The rods are made of aircraft duralumin and are in three sections which are held in place with the Lynch sliplocks, shown in the drawing. The rods are embedded in long insulators which are in turn screwed in the half-meter flanges provided with holes, through which wood screws may be used for supporting them to the cross members.

New Lynch 5-meter "Beam Array" Antenna. (No. 255)

(Continued on page 622)

Names and addresses of manufacturers of sets described on this and following pages furnished upon receipt of stamped envelope; mention No. of article.

All-Wave Communications Set

Has Range from 16.6 to 550 Meters

● THIS receiver is designed along lines which should be very desirable among the "hams" and short-wave "fans" in all classes. It is neat and businesslike in appearance and truly represents a professional type of receiver. The ACR 136 receiver has a range of 16.6 to 550 meters and with its especially designed dial can be adjusted to give band-spread at any point over the range it covers. It has one stage of high-gain, tuned radio frequency, which is tuned even on the shortest wave-band, thus affording maximum efficiency and a minimum of repeat points. This R.F. stage uses a 6D6. The converter section consists of a 6A7, which provides the functions of beat oscillator and first detector. A 6D6 is used as the intermediate frequency amplifier and another 6D6 for the C.W. beat oscillator. This beat oscillator provides a means of receiving continuous wave code, as well as a means for locating weaker stations



Above—new RCA All-Wave Communications Receiver; left, schematic wiring diagram. (No. 250)

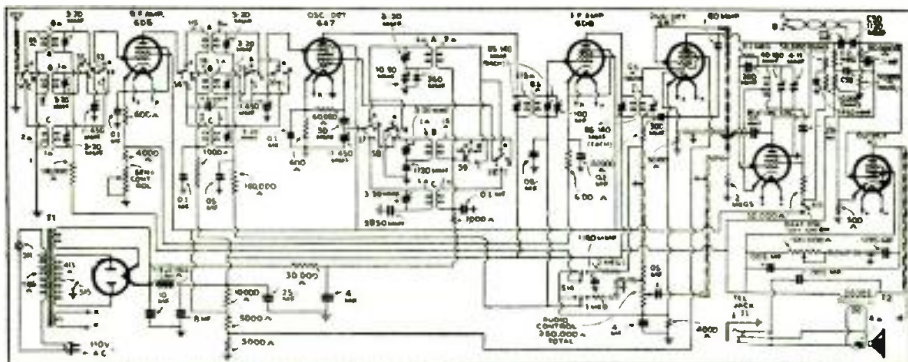

by providing a heterodyne beat note, which can be eliminated after the station has been located, simply by the flip of a switch. A 6B7 is used for second detector, A.V.C., and audio frequency amplification. There is a switch which also renders A.V.C. inoperative, A.V.C., of course, not being desired during code reception. All that is necessary to change to any one of the three bands which this set covers unbroken from 18,000 to 540 kc. is to turn the switch on the front panel.

A 3-Tube Loud-Speaker Set

● THIS neat appearing short-wave set, while having only three tubes, provides very high sensitivity and even speaker volume on some of the stronger stations. It uses screen-grid regenerative detector tube, and a 38 pentode audio amplifier. For maximum gain, a high impedance choke is used in the plate circuit of the detector. The entire set, including the loud-speaker, is housed in a very neat cracked finished metal case. It is of the A.C.-D.C. variety and can be operated from 110-volt A.C.-D.C. lighting circuit. The antenna control is conveniently mounted on the front of the panel in order that one does not have to reach behind the set to make a careful adjustment. A phone jack is also provided in the back of the cabinet and is used for the reception of the weaker stations. Four plug-in coils are used and

it covers a range of approximately 15 to 200 meters. Reference to the diagram will reveal the care that was taken in the design of this very efficient circuit.



The "World-Trotter 3." (No. 251)

behind the set to make a careful adjustment. A phone jack is also provided in the back of the cabinet and is used for the reception of the weaker stations. Four plug-in coils are used and

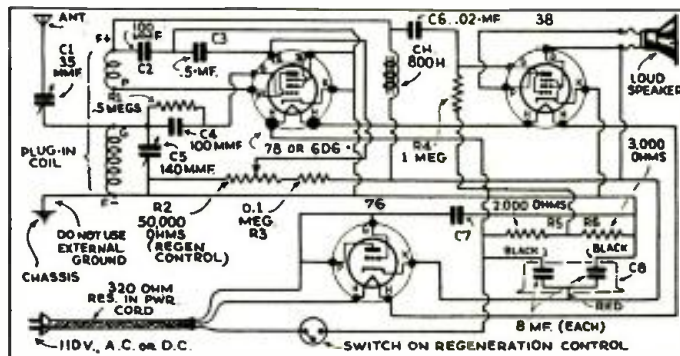

Wiring diagram of A.C.-D.C. "World-Trotter 3"

4 Tubes Go to "Work" in This Set

By ROBERT G. HERZOG, B.S.-E.E.*

● THE circuit of the "RGH 4" is a simple, highly efficient regenerative circuit carefully adapted to modern tubes and equipment. No feature of design has been overlooked to make this an exceptional receiver.

In wiring the set all the ground leads are connected together as well as to lugs on the chassis. Do not attempt to solder to the chassis itself. The "B" plus leads, are run around the edges of the chassis to leave the center clear for the small parts and more important wires. All soldered connections should be solid, made with a clean well-tinned hot iron. Use only rosin core solder. The antenna leads, the R.F. and detector plate and grid leads should be wired with heavy busbar from point to point. The leads to the caps of the tubes should be as short as possible with No. 18 flexible wire.

The resistors are mounted on small racks located near the respective tubes to which they are connected. This adds to the neatness as well as the efficiency of the receiver.

ANTENNA: The RGH 4 was originally designed to use a doublet antenna directly to the receiver without the use of couplers. However, good results have been obtained in locations where other disturbances are few on a 40- to 60-foot single antenna and good ground. In these cases a 30 to 70 mmf. trimmer was used in series with its lead-in.

Whether double or single antenna is used it is necessary to erect this "in the clear."

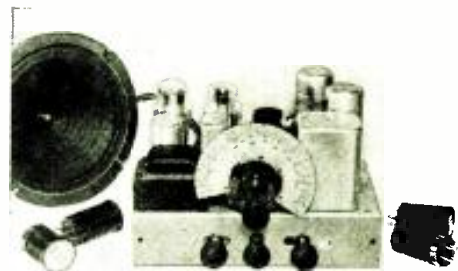

This view clearly shows layout of part.

*Chief Engineer, Thor Radio Co.

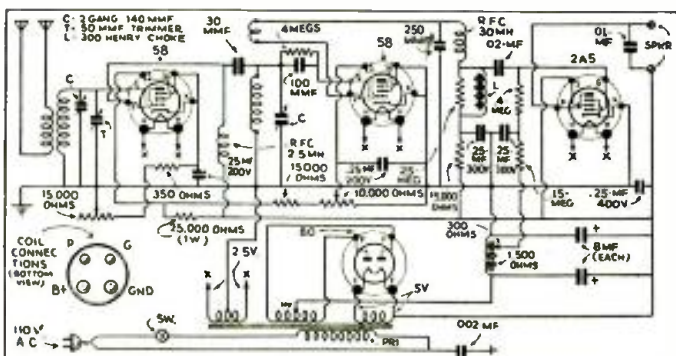

Diagram of new RGH 4 Receiver. (No. 252)

Names and addresses of manufacturers of sets described on this and following pages furnished upon receipt of stamped envelope; mention No. of article.

\$5.00 Prize Winner

COIL WINDING KINK

I use this kink constantly in winding my short-wave coils. I find it very handy because it eliminates calculating the position of the holes for each end of the winding. The sketch is practically self-explanatory. However, some things need to be explained. The slot should be cut straight down on both sides to make a neat job. At the same time, the doubled slot makes it possible to have half turns, especially on the very high frequencies (10 meters, etc.) where taking off or adding a half turn helps to spread the band over the dial.

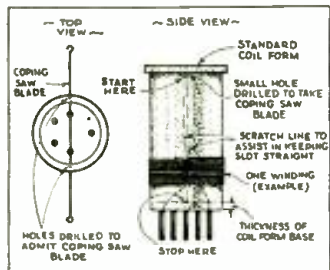

These slots make it convenient also to tap the coil in any turn for use in electron-coupling. Start winding all coils from the bottom or base of the coil form. This keeps the wire away from the top where constant removing of the coil from the set tends toward spoiling the appearance of the coils because the fingers come in contact with the wire. One more important point. Segment the windings permanently in place. One turn slipping loose will change the entire original "logging" of all stations.—Harold J. Clark.

COUPLERS AND EXTENSIONS

The materials needed are: Two old radio dials or knobs with the set screws, a length of old metal or fibre shafting and a metal or fibre washer, two old machine screws preferably brass about 3/4 inch in length and if you wish, nuts to fit. Break the dial or knobs until the brass centers are free. If one end of the brass centers are closed it will be necessary to cut them off with a hacksaw. Take the shaft and place a washer on it—then place the brass centers on the shaft—one on each side of the washer with the set screw ends farthest apart and tighten the set screws to hold firmly in position. Now drill a hole just a trifle smaller than the machine screws through each coupler a fraction of an inch on each side of the washer. Then take the unit apart and cut off the ends of the shaft quite near the holes so that you will have a small length of shaft with a hole in each end. Now assemble the unit just as you had it when you drilled it and drive the machine screws through the holes with a hammer and flatten the ends or put the nuts on and your coupler is complete. To make an extension use one old dial center and a brass or fibre shaft. Wooden dowel—the correct diameter make good shafts for insulated extenders. By placing an old dial coupler on the other end of the extension you can have an extra long coupler.—Sterling B. Mathews.

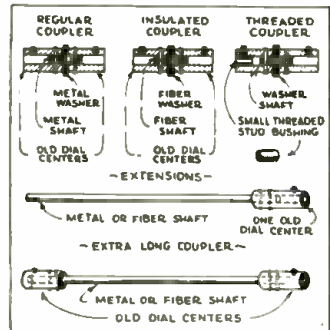

HOME MADE 2 BAND CONDENSERS

By remodeling an ordinary variable condenser as shown in the diagram and connecting a switch between the two stator sections two band reception can be obtained on a single coil. Just saw the supports for the stator plates in half, making two sections. A single pole, single throw switch is connected between the two stators in order to short circuit them when the entire capacity of the condenser is brought into play.—John Kondruk. This type of condenser can also be used in tuned R.F. receivers where conventional two gang condensers are necessary. When used for this purpose it will be necessary to mount a shield between the two stators and ground firmly in order to eliminate any coupling.

\$5.00 FOR BEST SHORT WAVE KINK
The Editor will award a five dollar prize each month for the best short-wave kink submitted by our readers. All other kinks accepted and published will be awarded eight months' subscription to SHORT WAVE CRAFT. Look over these "kinks" and they will give you some idea of what the editors are looking for. Send a typewritten or ink description, with sketch, of your favorite short-wave kink to the "Kink" Editor, SHORT WAVE CRAFT.

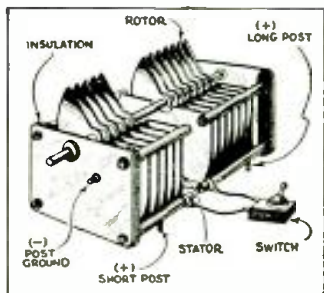

SHIELDED "MIKE" CABLES

When using "low-level" microphones, or any microphone for that matter, in conjunction with "high-gain" amplifiers, it is necessary to employ shielding. Where regular shielded microphone cables are not readily obtained, very efficient substitutes can be found in the flexible shielded antenna lead-in wire. On single button microphones only one piece of this wire is necessary. With double microphones, two of these will be necessary. Place them side by side and drop a small amount of solder on to them every four or five inches.

TIME SWITCH FROM ALARM CLOCK

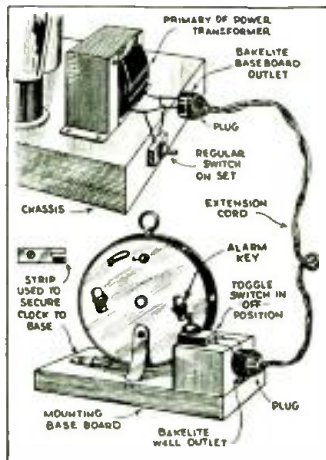

Here is a kink using an ordinary alarm clock (spring wind type) as a time switch to turn on your short-wave set or ordinary broadcast set so that you will not miss your favorite program, or if you own a transmitter and receiver using the time switch to turn on your short-wave set when you have a schedule so that you will not forget same. The clock is secured to a wooden base with a small strip of metal with a notch to hold each leg down and secured to the base with a small wood screw. An additional strip of metal behind the alarm key holds the switch in the proper position, as the alarm goes off it strikes on the top of the switch turning the set on.—Richard T. Schultz.

CHEAP COUPLING AND EXTENSION

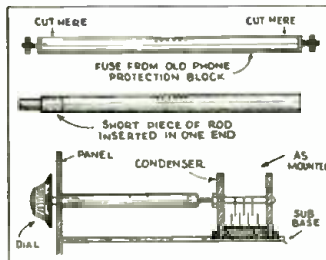

Old fuses that are used in the telephone protector system on most all phones make fine anti-capacity couplings for short-wave receivers as are used in the coupling and tuning circuits of short-wave sets. The ends are cut off and a short piece of 1/4 inch rod inserted in one end and shaft on condenser inserted in the other end. These old fuses are just the right size and a small amount of cement as is used for cementing wire on home-made coils is put in ends of tube before inserting rod and condenser shaft holds coupling very securely.—W. E. McLean.

SIMPLE SHAFT INSULATOR

Very often it is desired to insulate the electrically connected shaft of a volume or regeneration control from a metal chassis. Usually fibre washers with raised central portions are unavailable when needed and so I have resorted to the following simple method with great success. Place a flat insulating washer upon the shaft. Then twist a rubber band several times over the shaft until it is secure. Mount the object on the chassis with a washer on the other side and the job is complete.—Harry Klingener.

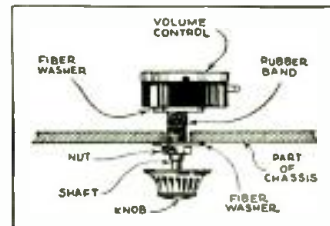

NOVEL METERING SYSTEM

Metering two or more stages with one meter is very simple if you use the following diagram. When you desire to meter a certain stage just plug a "dummy" plug into the desired jack and the meter will read that stage. If you have a 5-meter super-regenerative receiver no doubt you are very much troubled by the hissing noise. If you care to help cure this trouble you can do so by placing a .1 mf. condenser across the phones. Apparently the voice signals are little affected.—Jerry Pilgrim.

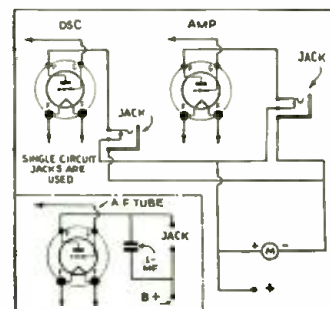

"MIKE" STAND

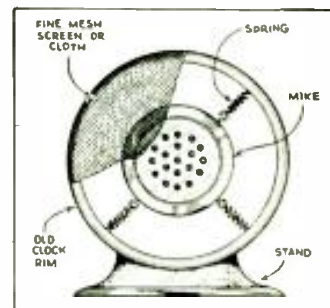

When wanting to make a "mike" stand and with no funds to be found, I turned to the trash box. After searching for quite a while I found an old Big Ben alarm clock, the case of which was in good condition. I removed all the working parts and levers including those for the control of the alarm having nothing left but the rim and stand. I then got four small springs, attached them to the hooks on the mike, and fastened the other ends to the rim of the clock by means of small bolts.—Joe Petsch.

MAKING WIRE COILS

In order to make heavy wire coil tightly on a bakelite form, wind the wire first on a form with a diameter about 1/32 smaller than the form to be used. The wire can then be threaded on larger form and will stay tight.—T.S.T.

NEON INDICATORS

About the handiest piece of apparatus around the "ham" station is the familiar neon bulb, which can be obtained in various sizes from 1/4 watt upward. These can be used for R.F. measurement, such as locating "standing" waves along transmission lines, or for lining up R.F. stages.

GROUND BUS-BAR

Here's how I solved my recent problem in building a set on a "bread board." I was at a loss as to where to "ground" my connections with as short leads as possible. This was solved by taking the long narrow strips of tin that you have left after opening a can of coffee. Taking this to my shop, I unwound it from its key to the length of my wood chassis; after cutting it to the proper length and tacking it into place, I soldered a clip taken from an old "B" battery to connect the ground wire to.—William Lutsen, Jr.

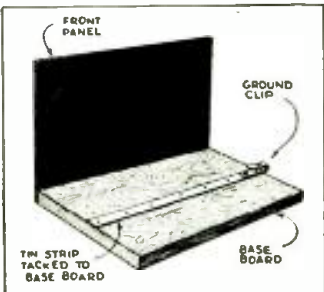

JUNK BOX RECTIFIER

This method will be found to be a very successful one when you do not feel equal to the price of a new Raytheon rectifier tube. All of the parts are inexpensive and you will most likely find them in the "junk box." Parts required are two type 201A tubes, one rheostat, one tube socket, one bell ringing transformer, or any other suitable low-voltage transformer. The filaments are connected in parallel. The plate and grid of each tube must be joined together or the voltage drop in the tubes will be excessive. Tubes such as the "71A" or "45" type will be found a little more efficient than the "201A's." If you are drawing current for a set using one or two large audio tubes such as the "217," "2A5," etc., which consume a heavy plate current, I have used an eliminator the same as this for a good length of time on a set using 58 TRF, 58 Det., and 217 audio built from SWC, and it works very efficiently and without breakdown.—Chas. Hamlin, Jr.

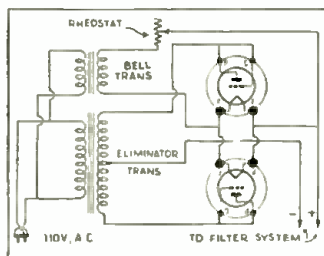

Short Wave Stations of the World

Complete List of Broadcast, Police and Television Stations

We present herewith a revised list of the short-wave broadcasting, experimental and commercial radiophone stations of the world. This is arranged by frequency, but the wavelength figures are also given for the benefit of readers who are more accustomed to working with "meters." All the stations in this list use telephone transmission of one kind or another

and can therefore be identified by the average listener.

Herewith is also presented a very fine list of police as well as television stations. Note: Stations marked with a star ★ are the most active and easily heard stations and transmit at fairly regular times.

Please write to us about any new stations or other important data that you

learn through announcements over the air or correspondence with the stations themselves. A post card will be sufficient. We will safely return to you any verifications that you send in to us. Communications of this kind are a big help.

Stations are classified as follows: C—Commercial phone. B—Broadcast service. X—Experimental transmissions.

Around-the-Clock Listening Guide

Although short wave reception is notorious for its irregularity and seeming inconsistency (wherein lies its greatest appeal to the sporting listener), it is a good idea to follow a general schedule as far as wavelength in relation to the time of the day is concerned. The observ-

ance of a few simple rules will save the short wave fan a lot of otherwise wasted time.

From daybreak till 4 p. m. and particularly during bright daylight, listen between 13 and 19 meters (21540 to 15800 kc.).

To the east of the listener, from about 5 a. m.-5 p. m., the 25-35 meter will be found very

productive. To the west of the listener this same band is best from about 7 P.M. until shortly after daybreak. (After dark, results above 35 meters are usually much better than during daylight.) These general rules hold for any location.

Short-Wave Broadcasting, Experimental and Commercial Radiophone Stations

21540 kc. W8XK -B- 13.93 meters WESTINGHOUSE ELECTRIC PITTSBURGH, PA. 7 a. m.-2 p. m.; relays KDKA	19220 kc. WKF -C- 15.60 meters LAWRENCEVILLE, N. J. Calls England, daytime	17810 kc. PCV -C- 16.84 meters KOOTWIJK, HOLLAND Calls Java, 6-9 a. m.	15880 kc. FTK -C- 18.90 meters ST. ASSISE, FRANCE Phones Saigon, morning	15270 kc. ★W2XE -B- 19.63 meters ATLANTIC BROADCASTING CORP. 485 Madison Av., N.Y.C. Relays WABC daily, 11 a. m.-1 p. m.
21420 kc. WKK -C- 14.01 meters A. T. & T. CO. LAWRENCEVILLE, N. J. Calls Argentina, Brazil and Peru, daytime	19160 kc. GAP -C- 15.66 meters RUGBY, ENGLAND Calls Australia, early a. m.	17790 kc. GSG -B- 16.86 meters BRITISH BROAD. CORP. DAVENTRY, ENGLAND "When to Listen In" Column	15810 kc. LSL -C- 18.98 meters HURLINGHAM, ARGENTINA Calls Brazil and Europe, daytime	15250 kc. W1XAL -B- 19.67 meters BOSTON, MASS. Irregular, in morning
21060 kc. WKA -C- 14.25 meters LAWRENCEVILLE, N. J. Calls England noon	18970 kc. GAQ -C- 15.81 meters RUGBY, ENGLAND Calls S. Africa, mornings	17780 kc. ★W3XAL -B- 16.87 meters NATIONAL BROAD. CO. BOUND BROOK, N. J. Relays WJZ, 10 a. m.-4 p. m. every day	15760 kc. JYT -X- 19.04 meters KEMIKWA-CHO, CHIBA- KEN, JAPAN Irregular in late afternoon and early morning	15243 kc. ★FYA -B- 19.68 meters "RADIO COLONIAL" PARIS, FRANCE Service de la Radiodiffusion 103 Rue de Grenelle, Paris 7:00-11 a. m.
21020 kc. LSN6 -C- 14.27 meters HURLINGHAM, ARG. Calls N. Y. C. 8 a. m.-5 p. m.	18830 kc. PLE -C- 15.93 meters BANDOENG, JAVA Calls Holland, early a. m.	17760 kc. DJE -B- 16.89 meters BROADCASTING HOUSE BERLIN, GERMANY Irregular 8 a. m.-2 p. m.	15660 kc. JVE -C- 19.16 meters NAZAKI, JAPAN Phones Java 3-5 a. m.	15220 kc. PCJ -X- 19.71 meters S. A. PHILIPS' RADIO EINDHOVEN, HOLLAND Broadcasts Sunday 8-11 a. m. relaying PHI
20700 kc. LSY -C- 14.49 meters MONTE GRANDE ARGENTINA Tests irregularly	18620 kc. GAU -C- 16.11 meters RUGBY, ENGLAND Calls N. Y., daytime	17760 kc. IAC -C- 16.89 meters PIZA, ITALY Calls ships, 6:30-7:30 a. m.	15620 kc. JVF -C- 19.2 meters NAZAKI, JAPAN Phones U.S., 5 a. m. & 8 p. m.	15210 kc. ★W8XK -B- 19.72 meters WESTINGHOUSE ELECTRIC & MFG. CO. PITTSBURGH, PA. 10 a. m.-4:15 p. m. Relays KDKA
20380 kc. GAA -C- 14.72 meters RUGBY, ENGLAND Calls Argentina, Brazil, mornings	18345 kc. FZS -C- 16.35 meters SAIGON, INDO-CHINA Phones Paris, early morning	17310 kc. W3XL -X- 17.33 meters NATIONAL BROAD. CO. BOUND BROOK, N. J. Relays WJZ Irregularly	15415 kc. KWO -C- 19.46 meters DIXON, CAL. Phones Hawaii 2-7 p. m.	15200 kc. ★DJB -B- 19.73 meters BROADCASTING HOUSE BERLIN, GERMANY 4-7:15 a. m.
19900 kc. LSG -C- 15.08 meters MONTE GRANDE, ARGENTINA Tests irregularly, daytime	18340 kc. WLA -C- 16.36 meters LAWRENCEVILLE, N. J. Calls England, daytime	17120 kc. WOO -C- 17.52 meters A. T. & T. CO., OCEAN GATE, N. J. Calls ships	15355 kc. KWU -C- 19.53 meters DIXON, CAL. Phones Pacific Isles and Japan	15140 kc. ★GSF -B- 19.82 meters BRITISH BROAD. CORP. DAVENTRY, ENGLAND See "When to Listen In" Column
19820 kc. WKN -C- 15.14 meters LAWRENCEVILLE, N. J. Calls England, daytime	18310 kc. GAS -C- 16.38 meters RUGBY, ENGLAND Calls N. Y., daytime	17080 kc. GBC -C- 17.56 meters RUGBY, ENGLAND Calls Ships	15340 kc. DJR -X- 19.56 meters BROADCASTING HOUSE BERLIN, GERMANY Testing irregularly	15120 kc. HVJ -B- 19.83 meters VATICAN CITY ROME, ITALY 5:00 to 5:15 a. m., except Sun- day. Also Sat. 10-10:30 a. m.
19650 kc. LSN5 -C- 15.27 meters HURLINGHAM, ARGENTINA Calls Europe, daytime	18250 kc. FTO -C- 16.43 meters ST. ASSISE, FRANCE Calls S. America, daytime	16270 kc. WLK -C- 18.44 meters LAWRENCEVILLE, N. J. Phones Arg., Braz., Peru, daytime	15330kc. ★W2XAD -B- 19.56 meters GENERAL ELECTRIC CO. SCHENECTADY, N. Y. Relays WGY daily, 2:30-3:30 p. m.	15090 kc. RKI -C- 19.88 meters MOSCOW, U.S.S.R. Phones Tashkent near 7 a. m. and relays RNE on Sundays irregularly
19600 kc. LSF -C- 15.31 meters MONTE GRANDE, ARGENTINA Tests irregularly, daytime	18135 kc. PMC -C- 16.54 meters BANDOENG, JAVA Phones Holland, early a. m.	16270 kc. WOG -C- 18.44 meters OCEAN GATE, N. J. Calls England, morning and early afternoon	15280 kc. DJQ -X- 19.63 meters BROADCASTING HOUSE BERLIN, GERMANY Tests Irregularly	15055 kc. WNC -C- 19.92 meters HIALEAH, FLORIDA Calls Central America, daytime
19380 kc. WOP -C- 15.48 meters OCEAN GATE, N. J. Calls Peru, daytime	18115 kc. LSY3 -C- 16.56 meters MONTE GRANDE, ARGENTINA Tests irregularly	16233 kc. FZR3 -C- 18.48 meters SAIGON, INDO-CHINA Calls Paris and Pacific Isles		
19355 kc. FTM -C- 15.50 meters ST. ASSISE, FRANCE Calls Argentine, mornings	18040 kc. GAB -C- 16.63 meters RUGBY, ENGLAND Calls Canada, morn. & early aftn.			

14980 kc. KAY
-C- 20.03 meters
MANILA, P. I.
Phones Pacific Isles

14950 kc. HJB
-C- 20.07 meters
BOGOTA, COL.
Calls WNC, daytime

14590 kc. WMN
-C- 20.56 meters
LAWRENCEVILLE, N. J.
Phones England
morning and afternoon

14535 kc. HBJ
-B- 20.64 meters
RADIO NATIONS.
GENEVA, SWITZERLAND
Broadcasts irregularly

14500 kc. LSM2
-C- 20.69 meters
HURLINGHAM, ARGENTINA
Calls U. S., evening

14485 kc. TIR
-C- 20.71 meters
CARTAGO, COSTA RICA
Phones Gen. Amer. & U.S.A.
Daytime

14485 kc. HPF
-C- 20.71 meters
PANAMA CITY, PAN.
Phones WNC daytime

14485 kc. TGF
-C- 20.71 meters
GUATEMALA CITY, GUAT.
Phones WNC daytime

14485 kc. YNA
-C- 20.71 meters
MANAGUA, NICARAGUA
Phones WNC daytime

14470 kc. WMF
-C- 20.73 meters
LAWRENCEVILLE, N. J.
Phones England
morning and afternoon

14440 kc. GBW
-C- 20.78 meters
RUGBY, ENGLAND
Calls U.S.A., afternoon

13990 kc. GBA
-C- 21.44 meters
RUGBY, ENGLAND
Calls
Buenos Aires, late afternoon

13610 kc. JYK
-C- 22.04 meters
KEMIKAWA-CHO, CHIBA-
KEN, JAPAN
Phones California till 11 p. m.

13585 kc. GBB
-C- 22.08 meters
RUGBY, ENGLAND
Calls
Egypt & Canada, afternoons

13415 kc. GCJ
-C- 22.36 meters
RUGBY, ENGLAND
Calls Japan & China early
morning

13390 kc. WMA
-C- 22.40 meters
LAWRENCEVILLE, N. J.
Phones England
morning and afternoon

12840 kc. WOO
-C- 23.36 meters
OCEAN GATE, N. J.
Calls ships

12825 kc. CNR
-B, C- 23.39 meters
DIRECTOR GENERAL
Telegraph and Telephone
Stations, Rabat, Morocco
Broadcasts, Sunday, 7:30-9 a. m.

12800 kc. IAC
-C- 23.45 meters
PIZA, ITALY
Calls Italian ships, mornings

12780 kc. GBC
-C- 23.47 meters
RUGBY, ENGLAND
Calls ships

12290 kc. GBU
-C- 24.41 meters
RUGBY, ENGLAND
Calls N.Y.C., afternoon

12150 kc. GBS
-C- 24.69 meters
RUGBY, ENGLAND
Calls N.Y.C., afternoon

12000 kc. RNE
-B- 25 meters
MOSCOW, U. S. S. R.
Sat, 10-11 p. m.
Sun, 6-7 a. m., 10-11 a. m.

11991 kc. FZS2
-C- 25.02 meters
SAIGON, INDO-CHINA
Phones Paris, morning

11950 kc. KKQ
-X- 25.10 meters
BOLINAS, CALIF.
Tests, irregularly, evenings

11940 kc. FTA
-C- 25.13 meters
STE. ASSISE, FRANCE
Phones CNR morning,
Hurlingham, Arge., nights

11875 kc. FYA
-B- 25.25 meters
"RADIO COLONIAL"
PARIS, FRANCE
11:15 a. m.-2:15 p. m., 3-6 p. m.

11870 kc. W8XK
-B- 25.26 meters
WESTINGHOUSE ELECTRIC
& MFG. CO.
PITTSBURGH, PA.
4:30-10:00 p. m.
Sat. till 1 a. m.
Relays KOKA

11860 kc. GSE
-B- 25.29 meters
BRITISH BROAD. CORP.
DAVENTRY, ENGLAND
See
"When to Listen In" Column

11855 kc. DJP
-X- 25.31 meters
BROADCASTING HOUSE
BERLIN, GERMANY
Tests irregularly

11830 kc. W2XE
-B- 25.36 meters
ATLANTIC BROADCASTING
CORP.
485 MADISON AVE., N. Y. C.
3-5 p. m. Relays WABC

11811 kc. I2RO
-B- 25.4 meters
E.I.A.R.
Via Montefi 5
ROME, ITALY
Reported on at 8 a. m.

11795 kc. DJO
-X- 25.43 meters
BROADCASTING HOUSE
BERLIN, GERMANY
Tests irregularly

11790 kc. W1XAL
-B- 25.45 meters
BOSTON, MASS.
Irregularly in the evening

11760 kc. DJD
-B- 25.51 meters
BROADCASTING HOUSE,
BERLIN, GERMANY
12-4:45 p. m.

11750 kc. GSD
-B- 25.53 meters
BRITISH BROAD. CORP.
DAVENTRY, ENGLAND
See
"When to Listen In" Column

11730 kc. PHI
-B- 25.57 meters
HUIZEN, HOLLAND
Daily ex. Tue. & Wed.
8:00-10 a. m.; Sat. till 10:30;
Sun. till 11 a. m.

11720 kc. CJRX
-B- 25.6 meters
WINNIPEG, CANADA
Daily, 8 p. m.-12 m.
Sunday, 3-10:30 p. m.

11720 kc. FYA
-B- 25.6 meters
"RADIO COLONIAL"
PARIS, FRANCE
7-10 p. m.
11 p. m.-1 a. m.

11680 kc. KIO
-X- 25.68 meters
KAHUKU, HAWAII
Tests in the evening

10770 kc. GBP
-C- 27.85 meters
RUGBY, ENGLAND
Calls
Sydney, Austral. early a. m.

10740 kc. JVM
-C- 27.93 meters
NAZAKI, JAPAN
Phones California evenings

10675 kc. WNB
-C- 28.1 meters
LAWRENCEVILLE, N. J.
Calls Bermuda, daytime

10660 kc. JVN
-C- 28.14 meters
NAZAKI, JAPAN
Tests 2-7 a. m.

10550 kc. WOK
-C- 28.44 meters
LAWRENCEVILLE, N. J.
Phones
Arge., Braz., Peru, nights

10520 kc. VLK
-C- 28.51 meters
SYDNEY, AUSTRALIA
Calls Rugby, early a. m.

10430 kc. YBG
-C- 28.76 meters
MEDAN, SUMATRA
5:30-6:30 a. m., 7:30-8:30 p. m.

10420 kc. XGW
-C- 28.79 meters
SHANGHAI, CHINA
Calls Manila and England, 6-9
a. m. and California late evening

10410 kc. PDK
-C- 28.80 meters
KOOTWIJK, HOLLAND
Calls Java 7:30-9:40 a. m.

10410 kc. KES
-X- 28.80 meters
BOLINAS, CALIF.
Tests evenings

10350 kc. LSX
-C- 28.98 meters
MONTE GRANDE,
ARGENTINA
Tests irregularly 8 p. m.-12 mid-
night. Used in Byrd Broadcasts

10330 kc. ORK
-C- 29.04 meters
RUYSSSELEDE, BELGIUM
Broadcasts 2:45-4:15 p. m.

10300 kc. LSL2
-C- 29.13 meters
HURLINGHAM, ARGENTINA
Calls Europe, evenings

10290 kc. DIQ
-X- 29.16 meters
KONIGSWUSTERHAUSEN,
GERMANY
Broadcasts irregularly

10260 kc. PMN
-C- 29.24 meters
BANDONG, JAVA
Calls Australia 5 a. m.

10250 kv. LSK3
-C- 29.27 meters
HURLINGHAM, ARGENTINA
Calls Europe and U. S., after-
noon and evening

10220 kc. PSH
-C- 29.35 meters
RIO DE JANEIRO, BRAZIL

10055 kc. ZFB
-C- 29.84 meters
HAMILTON, BERMUDA
Phones N. Y. C. daytime

9950 kc. GCU
-C- 30.15 meters
RUGBY, ENGLAND
Calls N.Y.C. evening

9890 kc. LSN
-C- 30.33 meters
HURLINGHAM, ARGENTINA
Calls New York, evenings

9870 kc. WON
-C- 30.4 meters
LAWRENCEVILLE, N. J.
Phones England, evening

9860 kc. EAQ
-B- 30.43 meters
P. O. Box 951
MADRID, SPAIN
Daily except Saturday, 5:15-7
p. m.; Saturday, 1-3 p. m.;
5:15-7:30 p. m.; Tues., Thurs.
and Sun. 5:15-7:30 p. m.

9840 kc. JYS
-X- 30.49 meters
KEMIKAWA-CHO, CHIBA-
KEN, JAPAN
Irregular, 4-7 a. m.

9800 kc. LSE
-C- 30.61 meters
MONTE GRANDE,
ARGENTINA
Tests irregularly

9790 kc. GCW
-C- 30.64 meters
RUGBY, ENGLAND
Calls N.Y.C., evening

9780 kc. I2RO
-B- 30.67 meters
E.I.A.R.
ROME, ITALY
Tues., Thurs., Sat., 2:30-5 or
6 p.m.

9760 kc. VLJ-VLZ2
-C- 30.74 meters
AMALGAMATED WIRELESS
OF AUSTRALIA
SYDNEY, AUSTRALIA
Phones Java and N. Zealand
early a. m.

9750 kc. WOF
-C- 30.77 meters
LAWRENCEVILLE, N. J.
Phones England, evening

9710 kc. GCA
-C- 30.89 meters
RUGBY, ENGLAND
Calls Arge. & Brazil, evenings

9600 kc. CT1AA
-B- 31.25 meters
LISBON, PORTUGAL
Tues. and Friday, 4:30-7 p. m.

9595 kc. HBL
-B- 31.27 meters
LEAGUE OF NATIONS
GENEVA, SWITZERLAND
Saturdays, 5:30-8:15 p. m.

9590 kc. VK2ME
-B- 31.28 meters
AMALGAMATED WIRELESS,
LTD., 47 YORK ST.
SYDNEY, AUSTRALIA
Sundays 1-3, 5-11 a. m.

9590 kc. PCJ
-X- 31.28 meters
S. A. PHILIPS' RADIO
EINDHOVEN, HOLLAND
Broadcasts irregularly

9590 kc. W3XAU
-B- 31.28 meters
NEWTOWN SQUARE, PA.
12 noon-7:50 p. m.

9580 kc. GSC
-B- 31.32 meters
BRITISH BROAD. CORP.
DAVENTRY, ENGLAND
See
"When to Listen In" Column

9580 kc. VK3LR
-B- 31.32 meters
Research Section,
Postmaster Gen'l's. Dept.,
61 Little Collins St.
MELBOURNE, AUSTRALIA
3:15-7:30 a.m. except Sun.

9575 kc. KZRM
-B- 31.33 meters
ERLANGER & GALINGER,
INC.
MANILA, PHIL. ISL.
Broadcasts irregularly from
5-9 a.m.

9570 kc. W1XAZ
-B- 31.35 meters
WESTINGHOUSE ELECTRIC
& MFG. CO.
SPRINGFIELD, MASS.
Relays WBZ, 7 a. m.-1 a. m.

9565 kc. VUB
-B- 31.36 meters
BOMBAY, INDIA
11 a. m.-12:30 p. m., Wed., Sat.

9560 kc. DJA
-B- 31.38 meters
BROADCASTING HOUSE,
BERLIN
8-11:30 a. m., 5:15-9:15 p. m.

9540 kc. DJN
-B- 31.45 meters
BROADCASTING HOUSE
BERLIN, GERMANY
4-7:15 a. m., 8-11:30 a. m.,
5:30-10:45 p. m.

9540 kc. LKJ1
-B- 31.45 meters
JELOY, NORWAY
Relays Oslo 10 a. m.-4 p. m.

9530 kc. W2XAF
-B- 31.48 meters
GENERAL ELECTRIC CO.
SCHENECTADY, N. Y.
Relays WGY 7:25-11 p. m.
Sundays, 7:25 p. m.-12:30 a. m.

9510 kc. GSB
-B- 31.55 meters
BRITISH BROAD. CORP.
DAVENTRY, ENGLAND
"When to Listen In" Column

9510 kc. VK3ME
-B- 31.55 meters
AMALGAMATED WIRELESS,
Ltd.
G. P. O. Box 1272L,
MELBOURNE, AUSTRALIA
Wed., 5-6:30 a. m.; Saturday,
5:00-7:00 a. m.

9500 kc. PRF5
-B- 31.58 meters
RIO DE JANEIRO, BRAZIL
Daily
except Sun. 5:30-6:15 p. m.

9428 kc. COH
-B- 31.8 meters
2 B ST. VEDADO,
HAVANA, CUBA
10-11 a. m., 5-6, 8-9 p.m.

9415 kc. PLV
-C- 31.87 meters
BANDONG, JAVA
Phones Holland, 7:40-9:40 a. m.

9330 kc. CJA2
-C- 32.15 meters
DRUMMONDVILLE, CANADA
Phones England irregularly

9280 kc. GCB
-C- 32.33 meters
RUGBY, ENGLAND
Calls Can. & Egypt, evenings

9170 kc. WNA
-C- 32.72 meters
LAWRENCEVILLE, N. J.
Phones England, evening

9020 kc. GCS
-C- 33.26 meters
RUGBY, ENGLAND
Calls N.Y.C., evenings

8775 kc. PNI
-C- 34.19 meters
MAKASSER, CELEBES,
D. E. I.
Phones Java around 4 a. m.

8760 kc. GCQ
-C- 34.25 meters
RUGBY, ENGLAND
Calls S. Africa, afternoon

8730 kc. GCI
-C- 34.36 meters
RUGBY, ENGLAND
Calls India, 8 a. m.

- 8680 kc. GBC**
 -C- 34.56 meters
 RUGBY, ENGLAND
 Calls ships
- 8560 kc. WOO**
 -C- 35.05 meters
 OCEAN GATE, N. J.
 Calls ships irregular
- 8380 kc. IAC**
 -C- 35.8 meters
 PIZA, ITALY
- 8185 kc. PSK**
 -C- 36.65 meters
 RIO DE JANEIRO, BRAZIL
 7-7:30 p. m. irregularly
 Relays PRA3
- 8036 kc. CNR**
 -B- 37.33 meters
 RABAT, MOROCCO
 Sunday, 2:30-5 p. m.
- 7901 kc. LSL**
 -C- 37.97 meters
 HURLINGHAM, ARGENTINA
 Calls Brazil, night
- 7880 kc. JYR**
 -B- 38.07 meters
 KEMIKAWA-CHO, CHIBA-
 KEN, JAPAN
 4-7:40 a. m.
- 7799 kc. HBP**
 -B- 38.47 meters
 LEAGUE OF NATIONS,
 GENEVA, SWITZERLAND
 5:30-6:15 p. m., Saturday
- 7400 kc. HJ3ABD**
 -B- 40.54 meters
 P. O. Box 509
 BOGOTA, COLOMBIA
 Daily 12-2 p. m.; 7-11 p. m.
 Sunday, 5-9 p. m.
- 7220 kc. HKE**
 -B- 41.55 meters
 BOGOTA, COL., S. A.
 Tue. and Sat. 8-9 p. m.; Mon.
 & Thurs. 6:30-7 p. m.
- 7140 kc. HJ4ABB**
 -B- 42.02 meters
 MANIZALES, COL., S. A.
 P. O. Box 175
 Mon. to Fri. 12:15-1 p. m.;
 Tues. & Fri. 7:30-10 p. m.;
 Sun. 2:30-5 p. m.
- 6977 kc. EAR110**
 -B- 43 meters
 MADRID, SPAIN
 Tues., Sat., 5:30 p. m.
- 6905 kc. GDS**
 -C- 43.45 meters
 RUGBY, ENGLAND
 Calls N.Y.C. evening
- 6860 kc. KEL**
 -X- 43.70 meters
 BOLINAS, CALIF.
 Tests irregularly
- 6755 kc. WOA**
 -C- 44.41 meters
 LAWRENCEVILLE, N. J.
 Phones England, evening
- 6750 kc. JVT**
 -X- 44.44 meters
 NAZAKI, JAPAN
 Relays JOAK, Tokio
 2-7:45 a. m.
- 6666 kc. HJ2RL**
 -B- 45.00 meters
 P. O. Box 759, GUAYAOUIL,
 ECUADOR, S. A.
 Sunday, 5:45-7:45 p. m.
 Tues., 9:15-11:15 p. m.
- 6660 kc. TIEP**
 -B- 45.05 meters
 LA-VOZ DEL TROPICO
 SAN JOSE, COSTA RICA
 Irregular in evening
- 6650 kc. IAC**
 -C- 45.1 meters
 PIZA, ITALY
 Calls ships, evenings
- 6620 kc. PRADO**
 -B- 45.30 meters
 RIOBANBA, ECUADOR
 Thur. 9-11:30 p. m.
- 6611 kc. RW72**
 -B- 45.38 meters
 MOSCOW, U. S. S. R.
 1-6 p. m.
- 6500 kc. HJ5ABD**
 -B- 46.14 meters
 MANIZALES, COL.
 12-1:30 p. m., 7-10 p. m.
- 6447 kc. HJ1ABB**
 -B- 46.53 meters
 BARRANQUILLA, COL., S. A.
 P. O. Box 715,
 11:30 a. m.-1 p. m.; 5-10 p. m.
- 6425 kc. W3XL**
 -X- 46.70 meters
 NATIONAL BROADCASTING
 CO.
 BOUND BROOK, N. J.
 Tests irregularly
- 6375 kc. YV4RC**
 -B- 47.06 meters
 CARACAS, VENEZUELA
 -B- 7:30-9:30 p. m.
- 6316 kc. HIZ**
 -B- 47.5 meters
 SANTO DOMINGO
 DOMINICAN REPUBLIC
 Daily except Sat. and Sun.
 4:40-5:40 p. m.; Sat., 9:40-
 11:40 p. m.; Sun., 11:40 a.
 m.-1:40 p. m.
- 6275 kc. HJ3ABF**
 -B- 47.81 meters
 BOGOTA, COLOMBIA
 P. O. Box 317
 12-1:30 p. m., 7-11 p. m., exe.
 Sunday, Wed. and Sat. 6-11 p.
 m., Tues. and Fri. 6:30-11 p. m.
- 6272 kc. HI1A**
 -B- 47.84 meters
 P. O. Box 245, SANTIAGO,
 DOMINICAN REP.
 11:40 a. m.-1:40 p. m.
 7:40-9:40 p. m.
- 6160 kc. YV3RC**
 -B- 48.7 meters
 CARACAS, VENEZUELA
 Generally 4:00-10:00 p. m.
- 6150 kc. CJRO**
 -B- 48.78 meters
 WINNIPEG, MAN., CANADA
 8 p. m.-12 p. m.
 Sun. 3-10:30 p. m.
- 6140 kc. W8XK**
 -B- 48.86 meters
 WESTINGHOUSE ELECTRIC
 & MFG. CO.
 PITTSBURGH, PA.
 Relays KDKA
 4:30 p. m.-1 a. m.
- 6130 kc. ZGE**
 -B- 48.92 meters
 KUALA LUMPUR,
 FED. MALAY STATES
 Sun., Tue. and Fri.,
 6:40-8:40 a. m.
- 6122 kc. JB**
 -B- 49 meters
 JOHANNESBURG,
 SOUTH AFRICA
 Daily except Sat. and Sun.,
 11:45 p. m.-12:30 a. m., 4-7
 a. m., 9 a. m.-3:30 p. m.
 Sat., only, 4-7 a. m., 9 a. m.,
 4:45 p. m.
 Sun., only, 11:45 p. m.-12:30
 a. m., 8-10:30 a. m., and 12:30-
 3 p. m.
- 6120 kc. YDA**
 -B- 49.02 meters
 N.I.R.O.M.
 BANDOENG, JAVA
 10:40 p. m.-1:40 a. m.,
 5:40-9:40 a. m.
- 6120 kc. W2XE**
 -B- 49.02 meters
 ATLANTIC BROADCASTING
 CORP.
 485 MADISON AVE., N. Y. C.
 Relays WABC, 6-11 p. m.
- 6115 kc. HJ1ABE**
 -B- 49.05 meters
 CARTAGENA, COL.
 P. O. Box 31
 Daily 11:15 a. m.-1 p. m.; Sun.
 9-11 a. m.; Mon. at 10 p. m.
 Wed. 8-10 p. m.
- 6112 kc. YV2RC**
 -B- 49.08 meters
 CARACAS, VENEZUELA
 Sun. 1:30-10:30 p. m., Daily
 except Sun. 11 a. m.-1:30 p. m.;
 Mon. Thurs., Sat. 5-10 p. m.;
 Tues., Wed. 5-9:30 p. m.; Fri.
 3-9:45 p. m.
- 6110 kc. VE9HX**
 -B- 49.10 meters
 HALIFAX, NOVA SCOTIA
 9:30 a. m.-1 p. m.; 6-12 p. m.
- 6110 kc. VUC**
 -B- 49.1 meters
 CALCUTTA, INDIA
 Daily except Sat., 3-5:30 a. m.,
 9:30 a. m.-noon;
 Sat., 11:45 a. m.-3 p. m.
- 6100 kc. HJ1ABD**
 -B- 49.18 meters
 CARTAGENA, COL.
 11:30 a. m.-12:30 p. m.; 7-9
 p. m.
- 6100 kc. W3XAL**
 -B- 49.18 meters
 NATIONAL BROADCASTING
 CO.
 BOUND BROOK, N. J.
 Relays WJZ
 Monday, Wednesday, Saturday,
 5:30 p. m.-1 a. m.
- 6100 kc. W9XF**
 -B- 49.18 meters
 DOWNERS GROVE, ILL.
 Relays WENR, Chicago
 Daily except Mon, Wed. & Sat.,
 2:30 p. m.-2 a. m.
- 6095 kc. VE9GW**
 -B- 49.22 meters
 BOWMANVILLE, ONTARIO,
 CANADA
 Sun. 1-9 p. m.
 Mon., Wed., 3 p. m.-12 m.
 Thurs.-Sat., 7 a. m.-12 m.
- 6090 kc. VE9BJ**
 -B- 49.26 meters
 SAINT JOHN, N. B., CAN.
 7-8:30 p. m.
- 6085 kc. IRA**
 49.3 meters
 E.I.A.R.
 Via Montello 5,
 ROME, ITALY
 Mon., Wed., Fri., 6:30-7:45
 p. m.
- 6080 kc. CP5**
 -B- 49.34 meters
 LAPAZ, BOLIVIA
 7-10:30 p. m.
- 6080 kc. W9XAA**
 -B- 49.34 meters
 CHICAGO FEDERATION OF
 LABOR
 CHICAGO, ILL.
 Relays WCFL
 Sunday 11:30 a. m.-9 p. m. and
 Tues., Thurs., Sat., 4 p. m.-12 m.
- 6079 kc. DJM**
 -X- 49.35 meters
 BROADCASTING HOUSE
 BERLIN, GERMANY
 Tests irregularly
- 6072 kc. OER2**
 -B- 49.41 meters
 VIENNA, AUSTRIA
 9 a. m.-3 p. m. daily
- 6070 kc. VE9CS**
 -B- 49.42 meters
 VANCOUVER, B. C., CANADA
 Sun. 1:45-9 p. m., 10:30 p. m.-
 1 a. m.; Tues. 6-7:30 p. m.,
 11:30 p. m.-1:30 a. m. Daily
 6-7:30 p. m.
- 6065 kc. HIX**
 -B- 49.46 meters
 SANTO DOMINGO
 DOMINICAN REPUBLIC
 Tues. and Fri., 8-10 p. m.;
 Sun., 7:45-10:40 a. m., 3-5 p.
 m.; Sat., 10:40-11:40 p. m.
- 6060 kc. OXY**
 -B- 49.50 meters
 SKAMLEBOAEK, DENMARK
 1-6:30 p. m.; also 11 a. m.-12 n.
 a. m.
 Sunday
- 6060 kc. W8XAL**
 -B- 49.50 meters
 CROSLY RADIO CORP.
 CINCINNATI, OHIO
 7:30 a. m.-8 p. m.; 11 p. m.-1
 a. m.
 Relays WLW
- 6060 kc. VQ7LO**
 -B- 49.50 meters
 NAIROBI, KENYA, AFRICA
 Mon., Wed., Fri., 5:45-6:15
 a. m., 11 a. m.-2 p. m.
 Tues., 3-4 a. m., 11 a. m.-2 p.
 m., Thurs., 8-9 a. m., 11 a. m.-
 2 p. m., Sat., 11 a. m.-3 p. m.,
 Sun., 10:50 a. m.-2 p. m.
- 6060 kc. W3XAU**
 -B- 49.50 meters
 NEWTOWN SQUARE, PA.
 Relays WCAU, Philadelphia
 8 p. m.-11 p. m.
- 6050 kc. GSA**
 -B- 49.59 meters
 BRITISH BROADCAST. CORP.
 DAVENTRY, ENGLAND
 See "When To Listen In" Col.
- 6040 kc. W1XAL**
 -B- 49.67 meters
 BOSTON, MASS.
 Tues., Thurs., Sun. 7:30-9 p. m.
- 6040 kc. YDB**
 -B- 49.67 meters
 N.I.R.O.M.
 SOERABAIA, JAVA
 10:40 p. m.-1:40 a. m.,
 5:40-9:40 a. m.
- 6020 kc. DJC**
 -B- 49.83 meters
 BROADCASTING HOUSE,
 BERLIN
 12 N.-4:45 p. m., 5:30-10:45
 p. m.
- 6012 kc. ZHI**
 -B- 49.9 meters
 RADIO SERVICE CO.,
 20 ORCHARD RD.,
 SINGAPORE, MALAYA
 Mon., Wed., Thurs., 5:40-8:10
 a. m.; Sat., 12:10-1:10 a. m.,
 10:40 p. m.-1:10 a. m. (Sunday)
- 6010 kc. COC**
 -B- 49.92 meters
 P. O. BOX 98
 HAVANA, CUBA
 Daily 9:30-11 a. m., 4-6 p. m.
 Sat. also at 11:30 p. m.
- 6005 kc. VE9DN**
 49.96 meters
 MONTREAL, CAN.
 Saturday 11:30 p. m.-12:30 a. m.
- 6000 kc. XEBT**
 -B- 50 meters
 MEXICO CITY, MEX.
 P. O. Box 79-44
 7 p. m.-1 a. m.
- 6000 kc. RW59**
 -B- 50 meters
 MOSCOW, U. S. S. R.
 Daily 3-6 p. m.; Sat. 10-11
 p. m.; Sun. 5:15-8 a. m.; 10-11
 a. m.
- 5970 kc. HJ2ABC**
 -B- 50.27 meters
 CUCUTA, COL.
 11 a. m.-12 n.; 6-9 p. m.
- 5968 kc. HVJ**
 -B- 50.27 meters
 VATICAN CITY (ROME)
 2-2:15 p. m., daily, Sun., 5:5-30
 a. m.
- 5940 kc. TGX**
 -B- 50.5 meters
 SR. M. NOVALES,
 GUATEMALA CITY, GUAT.
 Daily except Sun., 8-10 a. m.,
 1-2:30 p. m., 8 p. m.-12 m.
- 5930 kc. HJ4ABE**
 -B- 50.6 meters
 MEDELLIN, COLOMBIA
 Mon., 7-11 p. m.; Tues., Thurs.,
 Sat., 6:30-8:00 p. m.; Wed. and
 Fri., 7:30-11:00 p. m.
- 5880 kc. HJ2ABA**
 -B- 51.02 meters
 TUNJA, COL.
 1-2 p. m., 7:30-10 p. m.
- 5853 kc. WOB**
 -C- 51.26 meters
 LAWRENCEVILLE, N. J.
 Calls Bermuda, nights
- 5850 kc. YV5RMO**
 -B- 51.28 meters
 MARACAIBO, VENEZUELA
 5:15-9 p. m.
- 5792 kc. OA4AD**
 -B- 51.8 meters
 RADIO DUSA
 LIMA, PERU
 Irregularly 9-11:30 p. m.
- 5614 kc. HCK**
 -B- 52.3 meters
 QUITO, ECUADOR, S. A.
- 5660 kc. HJ5ABC**
 -B- 53 meters
 CALI, COLOMBIA
 11 a. m.-12 n.,
 Tues. and Thurs. 8-10 p. m.,
 Sun. 12 N.-1 p. m.
- 5077 kc. WCN**
 -C- 59.08 meters
 LAWRENCEVILLE, N. J.
 Phones England irregularly
- 5025 kc. ZFA**
 -C- 59.7 meters
 HAMILTON, BERMUDA
 Calls U.S.A., nights
- 4975 kc. GBC**
 -C- 60.30 meters
 RUGBY, ENGLAND
 Calls Ships, late at night
- 4820 kc. GDW**
 -C- 62.24 meters
 RUGBY, ENGLAND
 Calls N.Y.C., late at night
- 4752 kc. WOO**
 -C- 63.1 meters
 OCEAN GATE, N. J.
 Calls ships irregularly
- 4320 kc. GDB**
 -C- 68.44 meters
 RUGBY, ENGLAND
 Tests, 8-11 p. m.
- 4273 kc. RW15**
 -B- 70.20 meters
 KHABAROVSK, SIBERIA,
 U. S. S. R.
 Daily, 3-9 a. m.
- 4272 kc. WOO**
 -C- 70.22 meters
 OCEAN GATE, N. J.
 Calls ships irregularly
- 4107 kc. HCJB**
 -B- 73 meters
 QUITO, ECUADOR
 7:14-10:15 p. m., except Monday
- 4098 kc. WND**
 -C- 73.21 meters
 HIALEAH, FLORIDA
 Calls Bahama Isles
- 3600 kc. CT2AJ**
 -B- 83.5 meters
 PONTA DELGADA,
 SAO MIGUEL, AZORES
 Wed. and Sat. 5-7 p. m.
- 3490 kc. PK1WK**
 -B- 85.96 meters
 BANDOENG, JAVA
 Daily except Fri., 4:30-5:30
 a. m.

Television Stations

2000-2100 kc.

W2XDR—Long Island City, N.Y.
 W8XAN—Jackson, Mich.
 W9XK—Iowa City, Ia.
 W9XAK—Manhattan, Kansas.
 W9XAO—Chicago, Ill.
 W6XAH—Bakersfield, Calif.

2750-2850 kc.

W3XAK—Portable
 W9XAP—Chicago, Ill.

W2XBS—Bellmore, N.Y.
 W6XS—Los Angeles, Calif.
 W9XAL—Kansas City, Mo.
 W9XG—W. Lafayette, Ind.
 W2XAB—New York, N.Y.

42000-56000, 60000-86000 kc.

W2XAX—New York, N.Y.
 W6XAO—Los Angeles, Calif.
 W9XD—Milwaukee, Wis.
 W2XBT—Portable
 W2XF—New York, N.Y.

W3XE—Philadelphia, Pa.
 W3XAD—Camden, N. J.
 W10XX—Portable & Mobile (Vicinity of Camden)
 W2XDR—Long Island City, N.Y.
 W8XAN—Jackson, Mich.
 W9XE—Chicago, Ill.
 W9XAT—Portable
 W2XD—New York, N.Y.
 W2XAG—Portable
 W1XG—Boston, Mass.

Police Radio Alarm Stations

CGZ	Vancouver, B.C.	2452 kc.	KGZR	Salem, Ore.	2442 kc.	WPEI	E. Providence, R.I.	1712 kc.
CJW	St. Johns, N.B.	2416 kc.	KGZS	McAlester, Okla.	2458 kc.	WPEK	New Orleans, La.	2430 kc.
CJZ	Verdeen, Que.	2452 kc.	KGZT	Santa Cruz, Cal.	1674 kc.	WPEL	W. Bridgewater, Mass.	1666 kc.
KGHG	Las Vegas, Nev.	2474 kc.	KGZU	Lincoln, Neb.	2490 kc.	WPEN	Woonsocket, R.I.	2466 kc.
KGHK	Palo Alto, Cal.	1674 kc.	KGZV	Lubbock, Tex.	2458 kc.	WPEP	Arlington, Mass.	1712 kc.
KGHM	Reno, Nev.	2474 kc.	KGZX	Albuquerque, N.Mex.	2414 kc.	WPES	Saginaw, Mich.	2442 kc.
KGHO	Des Moines, Iowa	1682 kc.	KSW	Berkeley, Cal.	1658 kc.	WPET	Lexington, Ky.	1706 kc.
KGHX	Santa Ana, Cal.	2430 kc.	KVP	Dallas, Tex.	1712 kc.	WPEW	Northampton, Mass.	1666 kc.
KGHY	Whittier, Cal.	1712 kc.	VYR	Montreal, Can.	1712 kc.	WPEA	Newton, Mass.	1712 kc.
KGHZ	Little Rock, Ark.	2406 kc.	VYW	Winnipeg, Man.	2452 kc.	WPFC	Muskegon, Mich.	2442 kc.
KGJX	Pasadena, Cal.	1712 kc.	WCK	Belle Island, Mich.	2414 kc.	WPFE	Reading, Pa.	2442 kc.
KGLX	Albuquerque, N.M.	2414 kc.	WEY	Boston, Mass.	1558 kc.	WPFJ	Jacksonville, Fla.	2442 kc.
KGOZ	Cedar Rapids, Iowa	2466 kc.	WKDT	Detroit, Mich.	1558 kc.	WPFH	Baltimore, Md.	2414 kc.
KGPA	Seattle, Wash.	2414 kc.	WKDU	Cincinnati, Ohio	1706 kc.	WPEI	Columbus, Ga.	2414 kc.
KGPC	St. Louis, Mo.	1706 kc.	WMDZ	Indianapolis, Ind.	2442 kc.	WPEJ	Hammond, Ind.	1712 kc.
KGPD	San Francisco, Cal.	1674 kc.	WMJ	Buffalo, N.Y.	2422 kc.	WPEK	Hackensack, N.J.	2430 kc.
KGPE	Kansas City, Mo.	2422 kc.	WMO	Highland Park, Mich.	2414 kc.	WPEL	Gary, Ind.	2470 kc.
KGPG	Vallejo, Cal.	2422 kc.	WMP	Framingham, Mass.	1666 kc.	WPFM	Birmingham, Ala.	2382 kc.
KGPH	Oklahoma City, Okla.	2450 kc.	WPDA	Tulare, Cal.	2414 kc.	WPFN	Fairhaven, Mass.	1712 kc.
KGPI	Omaha, Neb.	2466 kc.	WPDB	Chicago, Ill.	1712 kc.	WPGO	Knoxville, Tenn.	2474 kc.
KGPP	Beaumont, Tex.	1712 kc.	WPDC	Chicago, Ill.	1712 kc.	WPGP	Clarksburg, W. Va.	2490 kc.
KGPK	Sioux City, Iowa	2466 kc.	WPDD	Chicago, Ill.	1712 kc.	WPGQ	Swathmore, Pa.	2474 kc.
KGPL	Los Angeles, Cal.	1712 kc.	WPDE	Louisville, Ky.	2442 kc.	WPGR	Johnson City, Tenn.	2470 kc.
KGPM	San Jose, Cal.	1674 kc.	WPDF	Flint, Mich.	2466 kc.	WPGS	Asheville, N.C.	2474 kc.
KGPN	Davenport, Iowa	2466 kc.	WPDG	Youngstown, Ohio	2458 kc.	WPGT	Portland, Me.	2422 kc.
KGPO	Tulsa, Okla.	2450 kc.	WPDH	Richmond, Ind.	2442 kc.	WPGU	Pawtucket, R.I.	2466 kc.
KGPP	Portland, Ore.	2442 kc.	WPDI	Columbus, Ohio	2430 kc.	WPGV	Palm Beach, Fla.	2442 kc.
KGPR	Honolulu, T.H.	2450 kc.	WPDJ	Milwaukee, Wis.	2450 kc.	WPGW	Miami, Fla.	2442 kc.
KGPS	Minneapolis, Minn.	2430 kc.	WPKD	Lansing, Mich.	2442 kc.	WPGA	Bay City, Mich.	2466 kc.
KGPT	Bakersfield, Cal.	2414 kc.	WPKL	Dayton, Ohio	2430 kc.	WPGH	Port Huron, Mich.	2466 kc.
KGPU	Salt Lake City, Utah	2406 kc.	WPKM	Auburn, N.Y.	2382 kc.	WPGI	S. Schenectady, N.Y.	1658 kc.
KGQX	Denver, Colo.	2442 kc.	WPKN	Akron, Ohio	2458 kc.	WPGJ	Rockford, Ill.	2458 kc.
KGQY	Baton Rouge, La.	1574 kc.	WPKO	Philadelphia, Pa.	2474 kc.	WPGK	Providence, R.I.	1712 kc.
KGQZ	Wichita, Kans.	2450 kc.	WPKP	Rochester, N.Y.	2382 kc.	WPGM	Findlay, Ohio	1596 kc.
KGZA	Fresno, Calif.	2414 kc.	WPKQ	St. Paul, Minn.	2430 kc.	WPGN	Albany, N.Y.	2414 kc.
KGZB	Houston, Tex.	1712 kc.	WPKR	Kokomo, Ind.	2490 kc.	WPGO	Portsmouth, Ohio	2430 kc.
KGZC	Topeka, Kans.	2422 kc.	WPKS	Pittsburgh, Pa.	1712 kc.	WPGP	Utica, N.Y.	2414 kc.
KGZD	San Diego, Cal.	2490 kc.	WPKT	Charlotte, N.C.	2458 kc.	WPGQ	Cranston, R.I.	2466 kc.
KGZE	San Antonio, Tex.	2482 kc.	WPKU	Washington, D.C.	2422 kc.	WPGR	Binghamton, N.Y.	2442 kc.
KGZF	Chanute, Kans.	2450 kc.	WPKV	Detroit, Mich.	2414 kc.	WPGS	South Bend, Ind.	2490 kc.
KGZG	Des Moines, Iowa	2466 kc.	WPKW	Atlanta, Ga.	2414 kc.	WPGT	Huntington, N.Y.	2490 kc.
KGZH	Klamath Falls, Ore.	2382 kc.	WPKX	Fort Wayne, Ind.	2490 kc.	WPGU	Mineola, N.Y.	2490 kc.
KGZI	Wichita Falls, Tex.	2458 kc.	WPKY	Syracuse, N.Y.	2382 kc.	WPGV	Boston, Mass.	1712 kc.
KGZJ	Phoenix, Ariz.	2430 kc.	WPKZ	Grand Rapids, Mich.	2442 kc.	WPGW	Mobile, Ala.	2382 kc.
KGZL	Shreveport, La.	1712 kc.	WPEA	Memphis, Tenn.	2466 kc.	WRBH	Cleveland, Ohio	2458 kc.
KGZM	El Paso, Tex.	2414 kc.	WPEB	Arlington, Mass.	1712 kc.	WRDQ	Toledo, Ohio	2474 kc.
KGZN	Tacoma, Wash.	2414 kc.	WPEC	New York, N.Y.	2450 kc.	WRDR	GrossePt.Village, Mich.	2414 kc.
KGZO	Santa Barbara, Cal.	2414 kc.	WPEE	New York, N.Y.	2450 kc.	WRDS	E. Lansing, Mich.	1666 kc.
KGZP	Coffeyville, Kans.	2450 kc.	WPEF	New York, N.Y.	2450 kc.			
KGZQ	Waco, Tex.	1712 kc.	WPEG	New York, N.Y.	2450 kc.			
			WPEH	Somerville, Mass.	1712 kc.			

When to Listen In

By M. Harvey Gernsback

Abbreviations

● THERE seems to be confusion about the call letters of several stations. The new Java stations in the 49-meter band are referred to as YDA, YDB and NIROM. The correct call letters of these stations are YDA and YDB. NIROM is merely the abbreviation of the name of the company operating these stations as NBC is an abbreviation for National Broadcasting Co. NIROM is the abbreviation for Nederlandsch-Indische Radio Omroep Maatschappij, which when translated into English means roughly "Dutch East Indian Broadcast Co."

The Italian broadcasting stations I2RO, I2RA, etc., are operated by the "Ente Italiano Audizioni Radiofoniche." The common abbreviated form of this is E.I.A.R. or simply EIAR.

Germany

Germany has already completed and put into regular service one of her new short-wave transmitters which was mentioned several months ago in this column. There are now three transmitters in use; a fourth is nearing completion. The latest schedule at hand is as follows: For Australia and East Indies, 3:45-7:15 a.m. on DJB, 15200 kc. and DJN, 9540 kc., also 8-11:30 a.m. on DJN.** For eastern Asia, 8-11:30 a.m. on DJA, 9560 kc.*** For Africa 12 n.-4:45 p.m. on DJD, 11760 kc. and DJC, 6020 kc.** For South America 5:15-9:15 p.m. on DJA. **For Central America 5:30-10:45 p.m. on DJN.*** For N. America 5:30-10:45 p.m. on DJC. Listeners should note that the program to N. America on DJB from 8:11-11:30 in the morning has been discontinued. It is possible that it will be resumed next

month when the fourth transmitter is completed. The German station uses only 5 kw. of power. The reason for the great signal strength of these stations is because of the use of intensely directional "beam antennae" at the station. These antennae concentrate the signal in the desired direction. One disadvantage is that people outside of the area to which the program is directed receive very weak signals from the station.

Rome

The new Italian stations are causing many new gray hairs to appear in radio editors' heads. They are trying to give better reception to their "foreign" listeners, so at the moment they are engaged in jumping from wave to wave in an effort to find the
 (Continued on page 616)

SHORT WAVE LEAGUE



HONORARY MEMBERS

- Dr. Lee de Forest
- John L. Reinartz
- D. E. Replogle
- Hollis Baird
- E. T. Somerset
- Baron Manfred von Ardenne
- Hugo Gernsback
- Executive Secretary*

"Code Test" Below 6 Meters Must Go!

Editor, SHORT WAVE CRAFT:

I wish you would kindly print the following regarding the "Code or No Code" controversy:

Two people within hearing distance of each other cannot make themselves understood without the aid of a telegraph key.

Q. Why not? Don't they both speak the same language?

A. Yes, but even if they didn't they would still need an interpreter.

Q. Then why do they need a key?

A. It's an old "Spanish" custom.

Q. But why don't they hold their conversation with their voices?

A. It's too simple and easy. The more difficult way is the best. Besides, they both can use a key.

Q. Strange! What manner of people are these?

A. They are what are known as "Hams". A very jealous and clannish tribe, most of them, inclined to be backward, and against progress; and very much addicted to "code".

Q. What is "code"?

A. An old and obsolete method of expressing one's self for great distances over the air before the discovery of the modulated wave.

Q. What is a modulated wave?

A. A means of transmitting speech over the air for great distances.

Q. Which method will cover the greatest distance?

A. Under the same given conditions the code—or C.W. wave—will carry further with more consistent success.

Q. Can phone transmission be perfected so that it will equal or better the performance of the C.W. transmitter?

A. Nothing is impossible. When this comes to pass you will see the telegraph key buried without any false sentimentality—

at least on the part of progressive and unbiased people. The government license examination can be made strict and hard enough so that none may pass save who deserve to. Those who pass will then go on the air with a phone and a knowledge of how to run it properly. But "code" and the "code test" must go. It is a product of the "Dark Ages in Radio."

Your very truly,

ROYAL W. WOODING,
4 Louise Park,
Roxbury, Mass.

Hi! He'll Give "Free" Code Instruction Book

Editor, SHORT WAVE CRAFT:

In regards to controversy pertaining to whether or not to have the "code test" for the band below 6 meters. I think that the present laws in regards to amateur stations are correct.

If the amateur has the ambition to own a station, why not go a step farther and learn the code? The U. S. Radio License requirements are very simple, and most any fourteen-years-old boy should be able to pass the code examinations after a few days of study.

Why don't the fellows who want a "Codeless" license get busy and learn the code?

For those who are interested in the Radio Code and will mail me a postcard I will send them "Free" a Telegraph Code instruction book, this offer is free to any one in the United States. I have several hundred of these books just off the press

R. F. FISHER,
R. F. FISHER ELECTRIC CO.,
3801 Riverside Ave., S.W.,
Cleveland, Ohio.

Reasons In Favor of "Code Test"

Editor, SHORT WAVE CRAFT:

In regard to all this discussion about code requirements on five meters, too many have the wrong viewpoint about code being obsolete and drudgery. In fact, after code knowledge is gained, it is very interesting to use, as well as being a help at times. Code equipment is not only simpler and easier to adjust, as well as being cheaper, but is capable of transmitting farther under adverse conditions than phone outfits.



Short Wave League

At a Directors Meeting held in New York City, New York, in the United States of America, the Short Wave League has elected

John F. Müller

a member of this League.

In Witness whereof, this certificate has been officially signed and presented to the above.

H. Winfield Secor
Club Secretary

This is the handsome certificate that is presented FREE to all members of the SHORT WAVE LEAGUE. The full size is 7¼" x 9½".

See page 636 how to obtain certificate.

Get Your Button

The illustration here-with shows the beautiful design of the "Official" Short Wave League button, which is available to everyone who becomes a member of the Short Wave League.

The requirements for joining the League are explained in a booklet, copies of which will be mailed upon request. The button measures ¾ inch in diameter and is inlaid in enamel—3 colors—red, white, and blue.



Please note that you can order your button AT ONCE—SHORT WAVE LEAGUE supplies it at cost, the price, including the mailing, being 35 cents. A solid gold button is furnished for \$2.00 prepaid. Address all communications to SHORT WAVE LEAGUE, 99-101 Hudson St., New York.

We have a "network" of five-meter phone stations here, transmitting every day and night for months, yet very often code is used in place of phone, as a change that is interesting and to keep interest alive as plain voice communication becomes monotonous time after time. Code practice is given on five meters to beginners so as to enable them to learn the code and secure licenses.

Licenses issued for five-meter work without a code test would be limited, of course, to that band, but I have yet to see the person who, sooner or later, did not lose interest in that band and desire to reach out on the other bands as this band is limited to local communication with ordinary locations and apparatus. This statement is the conclusion reached after months of constant association with this band and various amateurs.

The various articles published in SHORT WAVE CRAFT are all interesting, even though at the time they would seem uninteresting, some months later we became interested in

(Continued on page 615)

Short Wave

1 TUBE S.W. SET

Roy Haver, Delphos, Ohio,

(Q) Can I obtain the diagram of a one-tube short-wave receiver similar to the "One-Tube Scout" which was shown in SHORT-WAVE CRAFT some time ago?

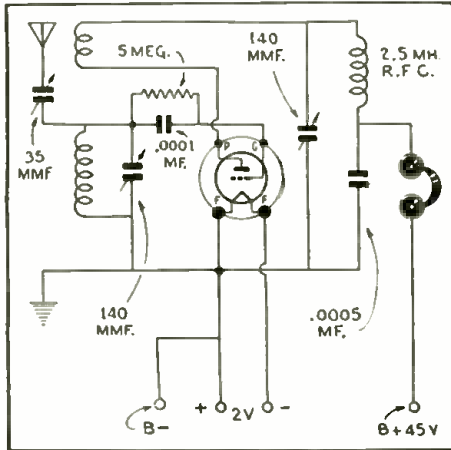

Above—diagram of 1-tube battery receiver.

(A) Above we are showing a diagram of a one-tube receiver that should give you excellent results. However, you must remember that a one-tube set does not give much volume and it is very easy to pass right over a station. Also the tuning is very critical and the antenna condenser must be continually adjusted. The antenna used with the above receiver should be at least 100 feet long and mounted as high in the air as possible.

2-STAGE AUDIO AMPLIFIER

J. G. Tate, Ardmore, Pa.

(Q) Would you please publish a diagram of a two-stage audio amplifier which can be used in conjunction with any 2-volt battery-operated short-wave receiver? This amplifier should use a type 30 as the first stage and a 31 as the output amplifier.

(A) We are very pleased to print the 2-tube audio amplifier diagram. C bias is necessary on both stages; a 22.5-volt C battery having a 4.5-volt tap will serve for both stages.

This amplifier in conjunction with a good battery-operated receiver should give loud-speaker volume on all "foreign" short-wave broadcast stations.

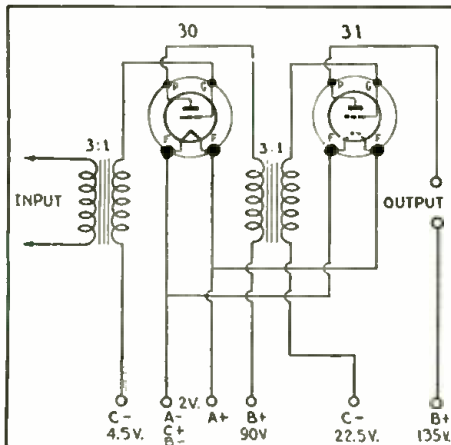

Two stage audio amplifier using dry-cell tubes. Note: bottom views of tube sockets are shown in the diagrams.

DOUBLET ANTENNA BEST?

J. Rand, New York City, N.Y.

(Q) Is the much talked about doublet antenna really better than a single-wire antenna?

(A) If properly constructed and mounted away from interfering objects, the doublet is far superior to the ordinary type. For constructional information we refer you to page 344 of the October 1934 issue. In cases where the flat-top portion of the doublet is not far from noise producing machinery, etc., there is little use of going to the trouble of changing your antenna.

19 TWINPLEX WITH 33 AUDIO

Ben Wolf, Burnet, Texas.

(Q) Will you please print a diagram of the 19 Twinplex with a 33-pentode audio amplifier?

(A) The 19 twinplex proved to be one of the most popular of our simple short-wave receivers. With the addition of a 33 pentode you should obtain excellent loud-speaker volume. Make sure that the .006 mf. by-pass condenser is connected in the plate circuit of the 33. A magnetic speaker can be used directly in the plate circuit of the 33. But phones should be coupled through a transformer.

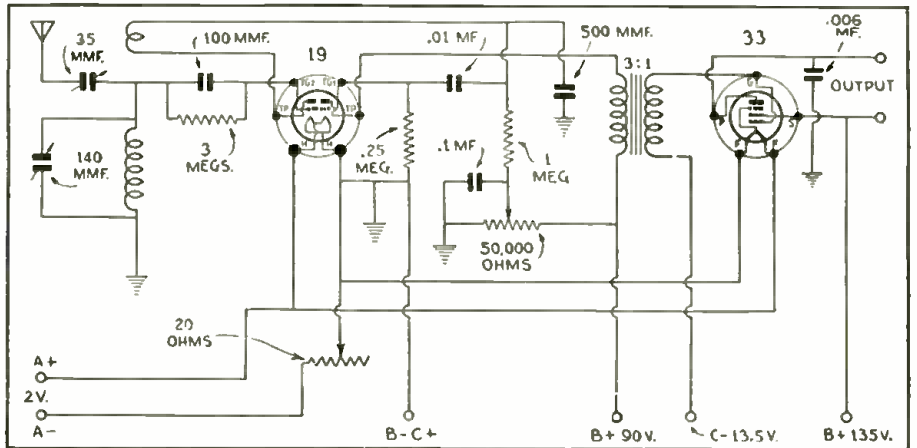

Diagram showing how to add a 33 pentode in the 19 Twinplex.

CRYSTAL TRANSMITTER

Fred Wahrenburg, Granite City, Ill.

(Q) I intend to build an amateur transmitter and would like some information. I would like a transmitter to work in the 40-meter band and have about 15 watts output. This is to be crystal-controlled.

(A) In our June 1934 issue, on page 86, there was a very complete article on a low-power crystal controlled transmitter; we suggest that you read it carefully.

(Q) I would also like to have some information on a simple 5-meter phone rig with about the same output.

(A) For a very efficient 5-meter transmitter we refer you to page 332 of the October 1934 issue.

TUNED R.F. STAGE FOR BATTERY SET

Norman W. Smith, London, Ont.

(Q) I have constructed the Victor "Easy Tune" receiver described in June issue of SHORT-WAVE CRAFT and would like to add a stage of tuned R.F. using a 34. Would you please print the diagram?

(A) The "Easy Tune" was a very fine set and no doubt you will obtain improved results with the addition of an R.F. stage. The diagram is shown to the right.

EDITED BY GEORGE

● Because the amount of work involved in the drawing of diagrams and the compilation of data, we are forced to charge 25c each for letters that are answered directly through the mail. This fee includes only hand-drawn schematic drawings. We cannot furnish "picture-layouts" or "full-sized" working drawings. Letters not accompanied by 25c will be answered in turn on this page. The 25c remit-

REMODELING B.C. SET FOR S.W. RECEPTION

Roy Magnuson, Minneapolis, Minn.

(Q) I have on hand an old Sparton A.C. 7 which I would like to convert into a short-wave receiver. I would appreciate any information or data that you can give me.

(A) From our past experience we have found that revamping broadcast sets in order to make them work on short waves is not a profitable proposition. We believe that it would be much more economical for you to either build a converter or an entirely separate short-wave receiver. In nearly every case where your idea has been carried out the net result has been a de-

stroyed broadcast set and a short-wave receiver that wasn't worth two "hoots." Refer to some of the past issues of SHORT-WAVE CRAFT magazine and you will find plenty of excellent short-wave sets.

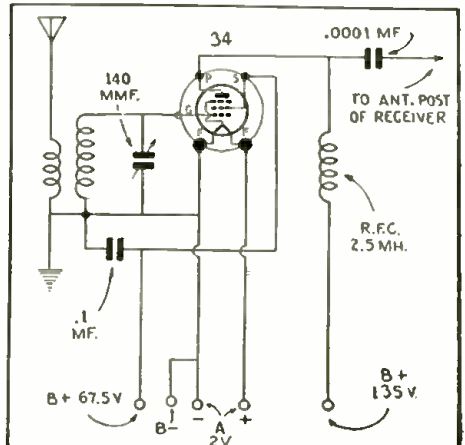

Tuned R.F. amplifier which can be added to any battery receiver.

QUESTION BOX

W. SHUART, W2AMN

tance may be made in the form of stamps or coin.

Special problems involving considerable research will be quoted upon request. We cannot offer opinions as to the relative merits of commercial instruments.

Correspondents are requested to write or print their names and addresses clearly. Hundreds of letters remain unanswered because of incomplete or illegible addresses.

✕ ADDING A 33 TO THE TWO TUBE DOERLE

N. J. Sundario, Jaro, Iloilo, P.I.

(Q) Kindly give us a circuit for adding a 33 pentode to the two-tube Doerle battery set. Would this be better than just changing the present 230 audio tube to a 33 pentode?

(A) The two-tube battery Doerle is a "Gem" and with the addition of a 33-pentode audio you should have lots of fun with it. We are printing the complete diagram.

(Q) The coils up to 200 meters have given excellent results. Now what I want is a coil that will cover the regular broadcast band.

(A) If your coil forms have a diameter

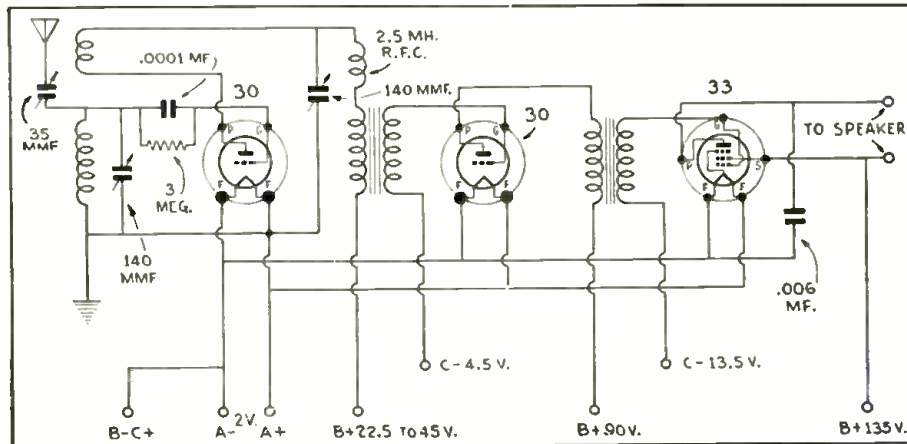

Circuit diagram of 2-tube battery Doerle with the addition of a 33 pentode.

of 1 1/4 inches the grid coil should have 120 turns of No. 28 enameled wire and 20 turns of the same size wire for the tickler. This will not cover the entire band with a 140 mmf. condenser but the major stations will be received.

LACK OF REGENERATION

L. H. Andrews, Manitoba, Canada.

(Q) I have recently wired up the Victor "Easy Tune" 2-tube Band Spreader illustrated in the June issue of SHORT-WAVE CRAFT. I cannot get regeneration below 31 meters. The wiring on the R.F. side is as short as possible, 35-foot antenna; my ground would have to be 20 feet, so I do not use one. I shall be very pleased if you can solve this problem for me.

(A) You may have insufficient number of tickler turns or your detector tube may not oscillate easily. Try another tube and also increase the number of tickler turns slightly. Also the antenna coupling condenser should have a very low minimum capacity.

3 TUBE SET WITH 6.3 VOLT TUBES

Lloyd W. Fohring, Cleveland Hgts., Ohio.

(Q) Would you please publish a diagram of a receiver using a 39 as a tuned

R.F. amplifier, a 37-regenerative detector resistance-coupled to a 38-pentode audio amplifier. This set is for the regular short-wave bands.

(A) To the right you will find a diagram using the above-mentioned tubes. This receiver can be run on 6 volts, either A.C. or D.C. and should give excellent results when used with a good antenna.

✕ TOO MUCH FEED-BACK

C. J. Fanslow, New York City, N.Y.

(Q) I built the 3-tube set using 24A, 27, and 27 which was shown in the September issue on page 293. When I turn the regeneration control up just a little there is a very high-pitched squeal in the phones. Below that point there seems to be no sensitivity. Disconnecting the antenna seems to make no difference. Can you help me?

(A) The trouble undoubtedly is too much regeneration and the detector is operating in super-regenerator fashion. The initial voltage in your power supply is probably so high that the adjustment of the potentiometer is very critical. Try increasing the .1 meg. resistor to 250,000 ohms and reducing the number of tickler turns slightly.

with a loud-speaker? This is for battery operation.

(A) In the oscillator circuit that we

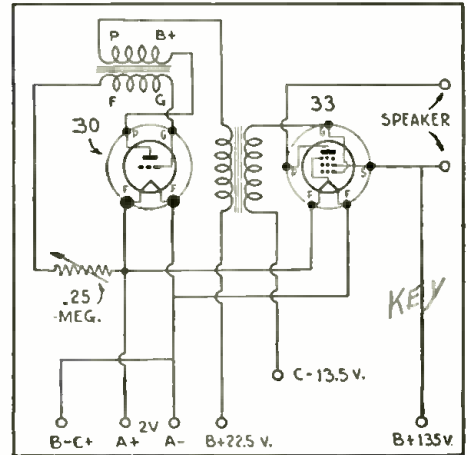

2-Tube Audio Oscillator for code practice.

have given, the oscillator tube is a 230 and the amplifier is a type 33. This should give enough volume for the average size room. The key is placed in the "B" plus lead of the oscillator; the variable grid-leak will provide a means of varying the tone. Two audio transformers are used, both of 3:1 ratio. The one in the oscillator circuit must be connected as shown. If no oscillation is obtained try reversing the leads to the primary winding.

The key should be placed in the B plus lead. A .002 mf. condenser across the key will reduce clicks. For increasing the pitch of the oscillator tune the secondary with a .0005 variable condenser.

COIL-WINDING FOR OSCILLODYNE

J. Linzmayr, Atlantic Highlands, N.J.

(Q) Please print in your QUESTION BOX the correct coil winding data for the one-tube Oscillodyne receiver.

(A) The coils for the Oscillodyne should be wound as follows, on 1 1/2 inch coil forms.

Approximate wave-length	Secondary turns	Primary turns
14- 25 meters	4	6
23- 41 meters	7	9
40- 85 meters	14	12
83-125 meters	23	23
120-200 meters	36	36

Spacing between tickler and grid coil 1/2 inch.

✕ CODE-PRACTICE OSCILLATOR FOR SPEAKER

C. W. Earley, Akron, Ohio.

(Q) Would you be kind enough to print in your QUESTION BOX, a diagram of a code-practice oscillator that can be used

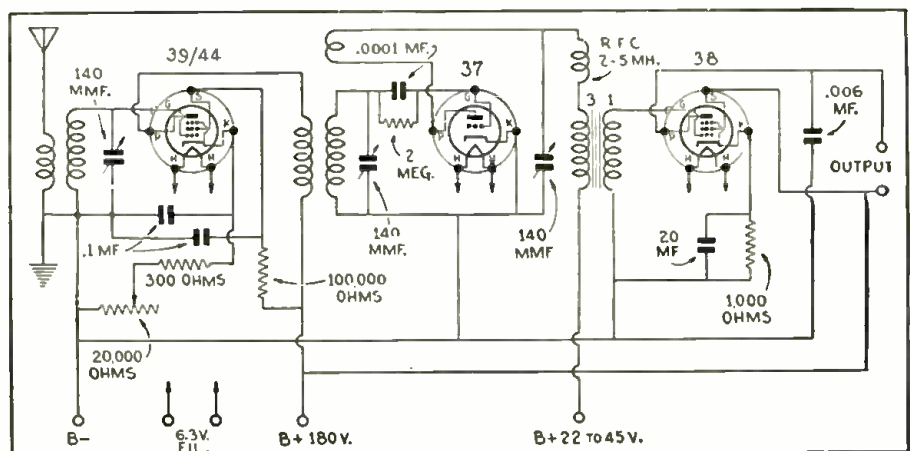

A 3-tube T.R.F. short-wave receiver using 6.3-volt tubes.

How You Can Obtain HIGH FIDELITY Results With Old Receivers

By WILHELM E. SCHRAGE

● Everyone today is demanding high fidelity. In this article, the author endeavors to set forth some worth-while short cuts in improving the "Sound Quality" of your present receiver.

● IF we look at the audio frequency spectrums of radio receivers generally in use today (see fig. 1) we recognize easily that their range of reproduction embraces the frequencies from 170 to 4500 cycles, despite the fact that scientific tests show us that for a true performance we need at least an audio frequency reproduction of from 50 to 7500 cycles and more! Now we can understand why musicians very often call radio music: "canned music"!

Their trained ear tells them there is a limited range of audio frequencies, certain high tones are lacking in power, but of real importance if we wish to obtain a *true tonal reproduction*. We can compare these audio frequencies which are lacking to the salt and the spices of our daily meals. We use small quantities of these only, but our trained tongue perceives at once any lack of these condiments.

When we recognize the bad acoustical "taste" of the radiated programs, we have no reason to complain that the radio studios use a "meat" of a bad quality, or serve poorly prepared "meals" for our ears. On the contrary the broadcasting companies engage the most famous artists, and these artists try their best to give us a first class performance. But an unwritten law of broadcasting technique makes them

accommodate their art to the limited reproduction range of ordinary receiving sets, which cannot reproduce the entire frequency range from 50 to 7500 cycles. It forces the broadcasting engineers to work week after week, to find a trick gadget that will reproduce in our loud-speaker sound waves, which give us the impression for example, that chains and keys are rattling and clanging in front of the microphone.

There are now many broadcasting stations in this country equipped with microphones and amplifiers to reproduce naturally the audio frequencies from 50 to 10,000 cycles, but nevertheless, the artist has to give us a makeshift version of his act, and the broadcasting engineer has to use trick gadgets only because our receivers do not reproduce the radiated program naturally. If we wish to obtain the full enjoyment of the first-class "meat," used in the "tone kitchen" of the broadcasting stations, it is up to us.

The recipe is quite simple. It consists of two points only: First we must eliminate all the sources of distortion in our receivers, and secondly we have to broaden the reproduction range of our sets.

Determining Distortion

Let's start with the distortion about which there is (Continued on page 626)

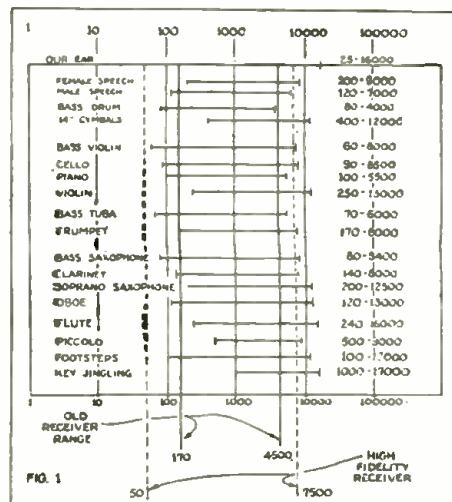

This graphic chart shows the acoustic frequency ranges of various musical instruments, as well as the human voice.

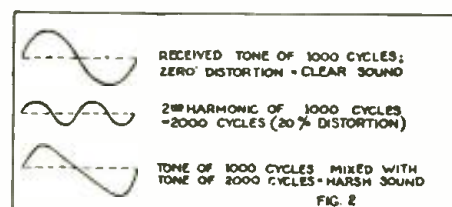

FIG. 2 shows harmonics and fundamental sound curves with resultant quality of sounds. Fig. 3—How "capacitive potentiometer" can be used to improve quality of sound. Fig. 4—Experimental "high fidelity" circuits.

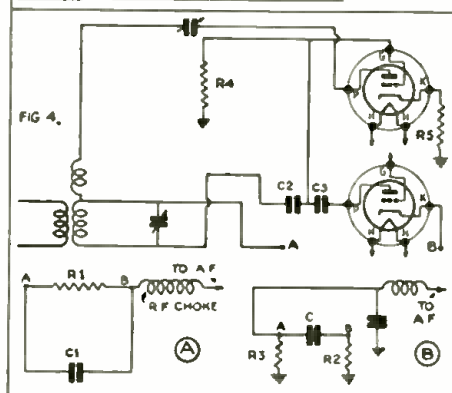

FIG. 4—Experimental "high fidelity" circuits. The diagram shows a transformer with primary terminals A and B, and secondary terminals A and B. A resistor R1 is connected across the secondary. A capacitor C1 is connected across the secondary. A resistor R2 is connected between the secondary terminals. A capacitor C2 is connected between the secondary terminals. A resistor R3 is connected between the secondary terminals. The output is taken from terminal A.

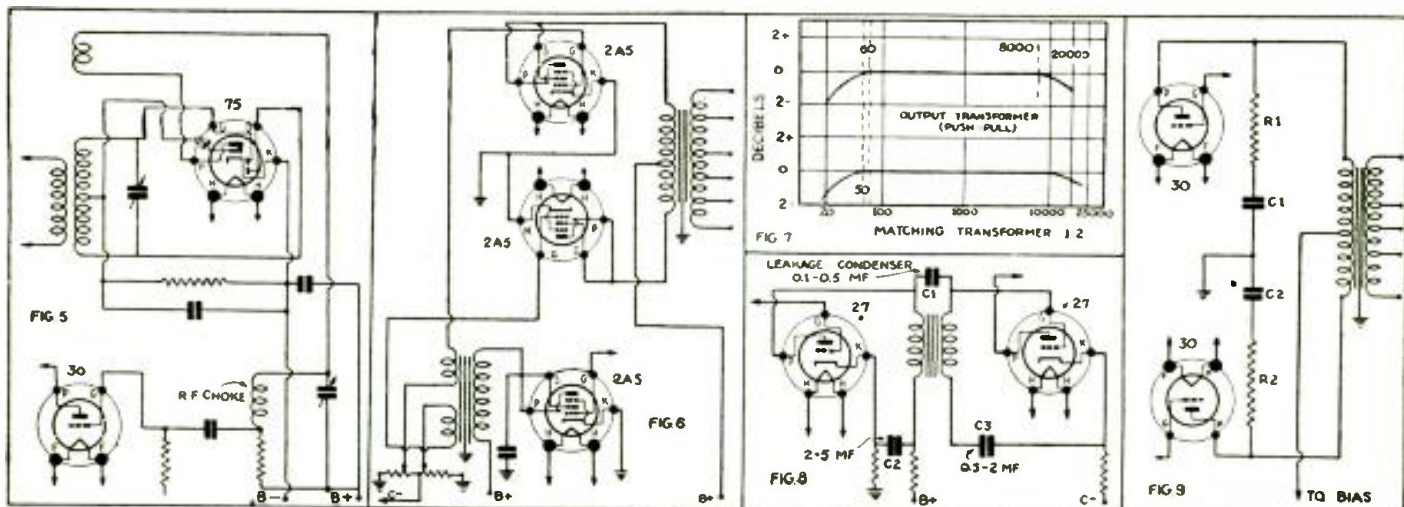

Fig. 5—Hook-up for duplex diode-triode. Fig. 6—Pentodes used as triodes. Fig. 7—High fidelity requires A.F. transformers to have a frequency response curve like that shown. Fig. 8—Connection of condenser to boost transformer at low frequencies. Fig. 9—Suggested way to stabilize impedance of speaker-output system by use of condenser-resistor network.

Calling All Cars On 10 Meters

(Continued from page 582)

very narrow and requires apparatus of great refinement, stability, selectivity, and reliability, to be successfully used.

The Newark police radio system, purchased from the Graybar Electric Company, was designed by Bell Telephone Laboratories and manufactured by the Western Electric Company, most of the work being done at their plant at Kearny, N.J.

All police communication facilities have been concentrated in three adjacent rooms on the fourth floor of Police Headquarters, at the City Hall on Broad Street, Newark. In one room is the police telephone switchboard and in another the police teletype machines. The third room located between these two is the radio room from which the police dispatcher broadcasts alarms to the motor patrol.

The radio room contains a microphone and amplifiers as well as maps of the city giving the position of every police car. A fire alarm indicator is also in this room. The dispatcher controls the entire radio system from this room by push-button control.

From here telephone and control lines lead to the 34th floor of the National Newark & Essex Bank Building, highest building in Newark, at which point is located the ultra-high frequency radio transmitter and duplicate dispatching equipment which makes it possible to continue operation even though cut off from headquarters by some unexpected emergency. The entire transmitting apparatus is contained in a single cabinet, 7 feet high and 1 foot, 9 inches wide. The transmitter draws its power directly from the power circuits of the building. Mercury-vapor rectifier tubes transform the alternating current into direct current of the proper voltage. Three tubes amplify the voice currents and there are four stages of amplification for the carrier or radio frequency.

Thin Quartz Crystal Stabilizes Waves

A quartz crystal of new type holds the transmitter on its assigned frequency with extreme accuracy. This tiny crystal, perhaps the most vital part in the system, is ground to paper thinness by skilled craftsmen using delicate machines. When so ground it has the characteristic of vibrating under electrical impulses at exactly one-sixth of the carrier frequency or about 5,000,000 times per second, and thus establishes the fundamental frequency of the transmitter. Hitherto the best crystals available have required the use of heating devices to maintain their operating temperature within the narrowest practicable limits. As a result of extensive research by Bell Telephone Laboratories, it has now become possible to manufacture crystals which do not require the complications of these accessories to achieve the desired constancy of oscillation frequency.

A series of vacuum tubes multiplies the electrical oscillations of the crystal until they reach 30,100 kilocycles (9.97 meters).

By several switches associated with four meters, the operator can instantly measure the performance of 14 circuits within the equipment. All tuned circuits can be locked to avoid tampering and to assure the permanence of adjustments once they are made. A blower in the top circulates cooling air through the transmitter, a spun glass filter at the bottom cleaning the air as it enters. The blower is rubber-mounted to prevent vibration. No live parts are exposed and a safety lock cuts out high voltages as soon as the back door of the transmitter is opened.

Concentric Transmission Line Used

From the transmitter a "concentric" transmission line runs 100 feet to the roof of the building. This line consists of two copper tubes, one within the other, the outer being a little less than an inch in

THE NEW FIVE-IN-THREE FULTONE V

All Electric—AC—DC—6F7—76—12A7

Here's the set that pulls 'em in!—It's inexpensive—But how those distant stations do roll in on the speaker! Even the most hard-boiled old-timer sits up and takes notice at the volume and clearness of speech with which D.J.D. and D.B.R. Germany; G.S.R. and G.S.C. England; E.A.Q. Spain; F.Y.A. France; and many others are received! And even those hard-to-get stations—J.V.N. Japan; V.K.3.M.E. and V.K.3.L.R. Australia; and I.N.E. Russia came in with surprising ease! Amateurs? From all over the world!

Here's the set that we know you will be proud to own! That will give you and your friends a thrill at every turn of the dial! Plugs into any 110 volt AC or DC house current outlet. Coils supplied tune from 15 to 200 meters. Provision for built-in speaker—external speaker—or headphones. Correct design insures full five tube performance—screen grid RF—regenerative detector—1st AF—Power pentode output and rectifier. All from three dual purpose tubes! Entirely self-contained. This is a receiver that is easy to build—easy to operate—and which will outperform higher priced sets! Correct design and the use of highest grade parts insures consistent and ever-remarkable performance for many years!

Order your Fultone V today! We know that you, too, will say—Excellent!!

SPECIAL COMBINATION OFFER \$12.75
Complete Kit, Tubes, Speaker Cabinet and Broadcast band coils
(Wired and Tested—add \$1.25)



Complete kit, including all necessary parts, crystal lined metal chassis with all holes, and complete, easily followed instructions..... **\$7.45**
Set of matched guaranteed Sylvania Tubes..... \$2.20
Metal cabinet as illustrated..... 1.25
Special loudspeaker..... 1.45
Two broadcast band coils..... 1.25

BATTERY MODEL FULTONE V
Full output with low current drain means economical long life of batteries. Four 1½ volt Dry Cells (or a 6 Volt storage battery) and three 45 Volt B Batteries are used. Complete Kit..... **\$6.95**
COMPLETE COMBINATION OFFER \$12.20

THE HARRISON ORIGINAL 12,500 MILE TWO TUBE SETS



Here's the set that everyone is talking about! We have sold thousands since we first introduced this excellent receiver over two years ago. Every S.W. station in the world has been received with these sets!

The remarkable performance, neat appearance, and low cost make this the outstanding value today! No skimming! The finest parts throughout!

Heavy chassis—audio transformer—four coils 15 to 200 meters—very efficient design. The simplicity of construction and ease of operation make it the ideal Beginner's Set!

Battery Model uses two type 30 tubes and inexpensive long life dry batteries. AC Model uses two 27 or 56 tubes. Either Model **COMPLETE KIT—\$4.45**
Set of two Sylvania Tubes—\$1.10

AC-DC ALL-ELECTRIC MODEL

The world famous Harrison 12,500 mile set with a built-in hum free power pack supplying all necessary heater and plate voltages. Entirely self contained. No batteries! Just plug into the 110 volt house line. Complete kit including drilled metal chassis, all parts, and clear pictures and diagrams. **\$5.95**



Set of three matched Sylvania tubes. \$1.50.

Any Kit on this page Assembled—Wired—and Tested..... **\$1.25**

HARRISON RADIO CO.
★ THE HOME OF FOUR STAR SERVICE ★

READ Like an Expert SEND CODE

Learn Quickly at Home—Get Real SPEED

It's easy, fascinating, to become a good up with the New MASTER TELEPLEX Code Teacher to help you. Only instrument ever produced which records your sending in visible dots and dashes—then sends back to you. Also sends practice work, recorded by an expert, at any speed you want. Thousands agree this method is surest, quickest—has taught more ops in past few years than all other systems combined. Used by U. S. Army, Navy, A. T. & T., R. C. A., and others. We furnish Complete Course, lend you Master Teleplex, give you personal instruction with a **MONKEY-BACK GUARANTEE**. Low cost. Send today for booklet R.S. 26; no obligation; post card will do.

TELEPLEX COMPANY
76 Cortland St.
New York, N.Y.

FREE BOOK



The FULTONE "DUETTE" ALL-ELECTRIC TWO-IN-ONE

4"x4"x5½" 2½ pounds complete
A powerful handful of radio that will surprise you with its volume and reception ability. European S.W. Broadcast stations are easily picked up with excellent headphone volume! Use the new two-in-one type 12A7 Tube! High gain pentode detector and power rectifier. A real powerful two tube receiver! This set is certainly no toy!

Small enough to fit in the palm of the hand! Very very inexpensive! Yet—the Fultone "Duette" has features found only in much higher priced receivers—Smooth action friction drive variable dial! Unit transformation controls—Front panel adjustment for sensitivity—Built in power supply providing all voltages needed. Set plugs into any 105 to 130 volt AC or DC house line—Line tube and tunable hum filter—Power switch—Attractive durable metal chassis and cabinet—Complete coverage from 15 to 625 meters (It costs everything!) Easy construction kit includes all necessary parts, drilled chassis and cabinet, 15 to 200 meter coils and final instructions. Sylvania 12A7 tube..... \$.95
200 to 625 meter broadcast band coil..... \$1.25

SPECIAL COMBINATION OFFER \$6.25
Complete Kit, tube, and B.C. coils
FULTONE "DUETTE" BATTERY MODEL
Uses the new type 12 tube—two separate tubes in one bulb! Detector and one stage audio amplifier. Economical operation on two dry cells and one or two B batteries. Complete easy construction kit as above..... **\$3.75**
COMBINATION OFFER \$5.50
Complete Kit, tube, and B.C. coils

A Mighty Mite!!



ACCESSORIES

Neat black crystal finished metal cabinet with hinged lid for the 12,500 Mile receiver. Protects tubes, coils, and wiring from damage and dust. **\$1.00**
Set of two broadcast band coils for any of the sets described above. Tune from 200 to 625 meters. Enables you to hear all the regular Broadcast stations and the long wave ship and gram transmitting frequencies by plugging in these coils. Make your set a real All-Wave Receiver! Set of two coils..... **\$1.25**
AC Power Pack for AC model. Delivers 250 volts and 2½ volts. Also excellent for amplifier or transmitter. Complete Kit \$3.45
Sensitive Light weight headphones; 2000 ohms. \$1.05; 4000 ohms. \$1.45
Complete Antenna kit—includes antenna wire, lead-in wire, insulators, ground clamp, knobs, etc..... **75c**

Dept. C-2 New York City
142 Liberty Street

AEROVOX

OIL-FILLED CAPACITORS

Ingenious design . . . selected materials . . . mass production. Result: Lowest-priced highest-quality units obtainable. Compact round or square metal containers . . . absolutely seepage proof . . . genuine high-tension insulators. Thoroughly dehydrated sections resist strain and capacity variation . . . oil-immersed . . . bathed in oil . . . compare quality . . . compare prices . . . compare performance. That's all! **FREE DATA:** 1935 Catalog just off press covers complete condenser and resistor line. Also free copy of monthly Research Worker.

AEROVOX CORPORATION
72 Washington Street
BROOKLYN, N.Y.



Please mention SHORT WAVE CRAFT when writing advertisers

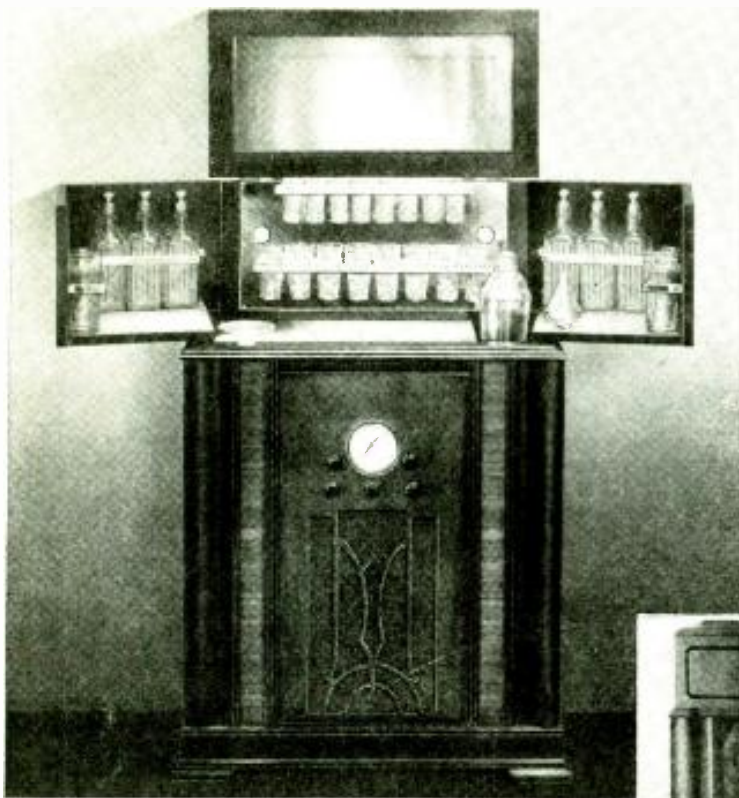

MODELS 505-506-508 OPEN

America's New Radio Sensation!

Radiobar

REG. U.S. PAT. OFF.

"RADIOBAR" is America's greatest value in radio. It gives you a handsome piece of furniture, a fine radio, and when opened a cocktail bar!

Model 105 and 106—"RADIOBAR" Walnut Finish Cabinet. Size when closed 43 1/2" high, 27" wide, 13" deep. When opened it is 54" high, 45" wide. The equipment includes six highball glasses, six cocktail glasses, four whiskey glasses, four liquor decanters, one ice container and one electric light. Fittings are of heavy chromium plate.

Model 505, 506, and 508—"RADIOBAR" Walnut Cabinet. Beautiful matched grain Oriental and Butt Walnut. Size when closed 45 3/4" high, 30 1/2" wide, 16" deep. When open it is 58 3/4" high, 54 1/2" wide.

The equipment includes eight cocktail or small highball glasses, eight liquor glasses and six large highball glasses, six liquor decanters, one ice container, one refuse container, two electric lights, cocktail shaker, funnel, stainless steel knife and special corkscrew and bottle opener. Space is provided for seltzer water and ginger ale bottles.

Model 105—"RADIOBAR" The radio is the latest 5-tube short wave (19 to 50 meters). American

and foreign broadcast. RCA licensed chassis. Price complete, \$99.50. Less Radio, \$69.50.

Model 106—"RADIOBAR" The radio is the latest 6-tube full all wave (15 to 575 meters). RCA licensed chassis. Price complete \$119.50. Less Radio, \$69.50.

Model 505—"RADIOBAR" The radio is the latest 5-tube short wave (19 to 50 meters). American and foreign broadcast. RCA licensed chassis. Price complete, \$139.00. Less Radio, \$109.00.

Model 506—"RADIOBAR" The radio is the latest 6-tube full all wave (15 to 575 meters). RCA licensed chassis. Price complete, \$159.00. Less Radio, \$109.00.

Model 508—"RADIOBAR" The radio is the latest 8-tube full all wave (15 to 575 meters). RCA licensed chassis. Price complete, \$189.00. Less Radio, \$109.00.

OTHER MODELS No. 528, \$249; No. 510, \$295; No. 526, \$219.

WRITE FOR DETAILED INFORMATION. DISTRIBUTORS AND DEALERS FULLY PROTECTED.

RADIOBAR COMPANY OF AMERICA

13 East 47th St.
New York, N.Y.

7100 McKinley Ave.
Los Angeles, California, U.S.A.



diameter and the inner somewhat smaller than a pencil. This one is held precisely in the middle of the outer by spaced rings of insulating material known as isolantite. The outer tube is bare of insulation, coming directly in contact with bricks, plaster, etc., and acting as a ground.

The unique design of this transmission line makes it "water tight" as far as electric current is concerned. The entire electrical field is concentrated within a small space, none escaping beyond the outer tube. There is no loss of energy by radiation.

This line enters the bottom of a hollow steel flagpole which rises 100 feet from the roof of the building. The line runs up the inside of the pole to its tip. Projecting from the tip is a brass tube 22 feet high. The inner tube of the transmission line also projects from the tip of the flag pole, paralleling the brass tube about 7 feet. This sets up an electrical effect which prevents current from surging back into the transmission line and maintains a uniform current in the line. The remaining 15 feet of the brass tube, about 600 feet above street level, become the actual antenna or radiator, being half the length of the radio wave.

About 25 police cars are equipped with receiving sets, the total planned being 40. The plan also calls for receiving sets in headquarters, precinct stations and the homes of a number of police and other city officials. A number of Fire Department official cars will likewise be equipped.

6 Tube Superhet Receivers Employed

The receiving sets are of the 6-tube superheterodyne type. They are 6 by 7 by 10 inches in size, including the loud-speaker. Their operation is simple, involving only two controls, both located on the receiving set. One is the on-off switch which also controls volume. The tuning of the receivers is fixed when they are first installed and the second control is merely to adjust them for small "drifts" in frequency, which may be necessary once or twice a day. This drift control is required on account of the extremely sharp tuning characteristic with which the receivers are designed to eliminate the possibility of interference. This second control can at any time be done away with by equipping the receivers at low cost with the same type of quartz crystal frequency control utilized in the transmitter, thus making the drift control automatic and still retaining the sharp tuning characteristic.

The loud-speakers also have automatic volume control, preventing any sudden bursts of sound and similarly maintaining the volume in spots where reception weakens, such as behind some buildings which cast a "radio shadow."

In the Ford coupes used by the Newark police, the car receivers are located to the rear of the seat. Rubber mountings protect them from jolts and vibration. The antennas are completely concealed so that radio cars, if otherwise unmarked, cannot be identified. The sets are operated by dynamotors which draw their power from the batteries of the cars.



CLOSED

HIT OF THE SHOW!



PERFORMANCE

At a recent demonstration of the new POSTAL '35, before a gathering of well known amateurs and short wave fans, the POSTAL '35 Custom Built receiver outperformed the set that won all foreign DX records.

CAPTAIN HORACE L. HALL

the famous Short Wave Authority who writes for the New York Sun, Radio Tower, Radio News and many foreign publications, choose the New POSTAL '35 for his DX listening post. Proof of its superiority.

OVER 50 IMPORTANT FEATURES

Such as the Postal drawer coils, built in T.R.F. pre-selector stage, continuous bandspread, A.V.C., Audio and R.F. volume control, two 4 1/2 inch calibrated airplane dials, precision tuning meter, 10 tubes, etc.

SOLD WITH A 10 DAY TRIAL MONEY BACK GUARANTEE
WRITE IMMEDIATELY FOR FREE DESCRIPTIVE PAMPHLET NO. 140 AND SPECIAL PRICES TO SWC READERS.

POSTAL RADIO
135 LIBERTY ST. NEW YORK, N.Y.

NEW 1935 S. W. BOOSTER
The new Postal custom built two stage pre-selector is the only two stage self powered short wave booster on the market. Easily connects to any all-wave receiver and is guaranteed to improve reception over 100%.
WRITE IMMEDIATELY FOR FREE 16 PAGE DESCRIPTIVE BOOKLET

SHORT WAVE MANUAL FOR 10 CENTS

● Would you like to obtain, for ten cents, a 1935 SHORT WAVE MANUAL, put out by the famous house of Hammarlund, and containing numerous articles on the construction of short-wave receivers? This SHORT WAVE MANUAL contains numerous articles, including "A Boy Scout's S.W. Receiver"; The Dragnet; The Sporting Twin Receiver; The Argonaut; A Power-Pack for S.W. Receivers; The Gainer Two-Tuber; 3-Tube Band-Spread A.C. Set; The Ray 5-Meter Set; The Famous Doerle 2-Tube Receiver; The Pentaflex; A Dual Regenerative Receiver; The A.R.R.L. "Ham" Receiver.

Simply send your name and address, together with 10c (simply to cover the cost of mailing and addressing), and ask for Book No. 503 to the following:

Service Department
SHORT WAVE CRAFT
99-101 Hudson St.
New York City

Please mention SHORT WAVE CRAFT when writing advertisers

A 13-200 Meter Converter

(Continued from page 601)

verter itself in the accompanying photographs.

Four tubes are used. The mixer or first detector V1 is a 6C6, the local oscillator V2 a 76. Four pairs of fixed coils, with suitable trimmer condensers, are controlled by a 5-position switch, giving comfortably spread out bands as follows: 1.5 to 5.2 megacycles, 3 to 6.8 mc., 5.7 to 12.5 mc., and 11.5 to 25 mc. In the fifth position the switch connects the aerial directly to the broadcast receiver.

A special three-foot length of shielded cable is provided to connect the output of the converter to the input posts of the B.C. receiver. Providing the latter itself has good shielding, this cable prevents pick-up of broadcast signals when the converter is in use. Pick-up of this kind is common with un-

ter showed its than a minute to , with the latter ediate brought n downtown New us amateurs and

ve Converter ist variable condenser

mer ner frequency choke

V2—100
V3—6D6 tube
V4—80 tube

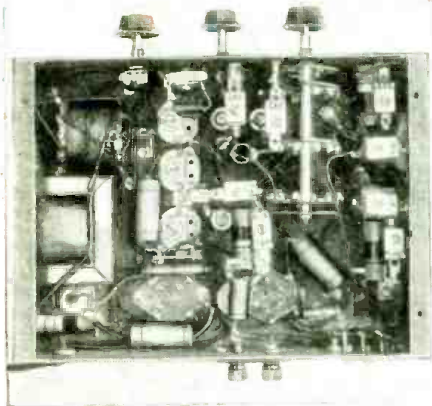

Underside of S-W Converter

S. W. League

(Continued from page 609)

building some set or transmitting part, so out would come the back issues and we would find that briefly read article which was just the dope needed. So continue to give your readers a variety of constructional articles and may everyone, sooner or later, find one that has just what he wants all set for him.

If, as you say, some persons are unable to learn the code, the only thing for them to do is to become "radio announcers." HIL.

Sincerely,
C. T. SHEAKS, WSKSG.
401 Highland Ave.,
Turtle Creek, Pa.



OFFICIAL RECORD—
(never equalled)
56½ WPM
CHICAGO
1922

AUTHENTIC RECORD—
(not in tournament)
73 WPM
CHICAGO
1933

T. R. McElroy

World's Fastest Radio Telegrapher*

Announces the
Mac-Key

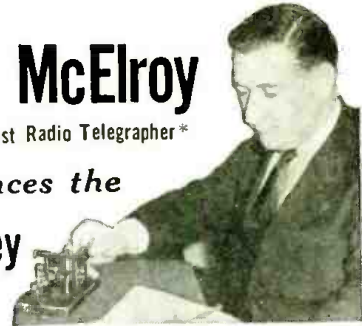

Official champion of the world, 1922 to 1933

"I'll not write a lot of bunk about my key. I'll tell you these truths: Each Mac-Key is adjusted by myself and shows perfect speeds 8 wpm to 45 wpm; each is an exact duplicate of the key with which I've established records in sending Morse & Continental code these past 15 years. Each is sold with my guarantee that you can send better with a Mac-Key than with any other instrument made—or your money refunded after 5 days trial."

- 1—Correctly designed vibration damper.
- 2—Straight key changeover lever.
- 3—Absolutely accurate speed adjustment.
- 4—Heavy 3/16 sensitive & costly contact points on bars for correct alignment.
- 5—Main spring selected after costly metallurgical research and personal, painstaking experimental work.
- 6—Base & superstructure, one piece, extra heavy cast-iron. Rigidity necessary for accurate smooth rhythmical sending.
- 7—Dash lever suspended from main lever. This is one of the most important features of my key. All levers on tool steel pintons swung

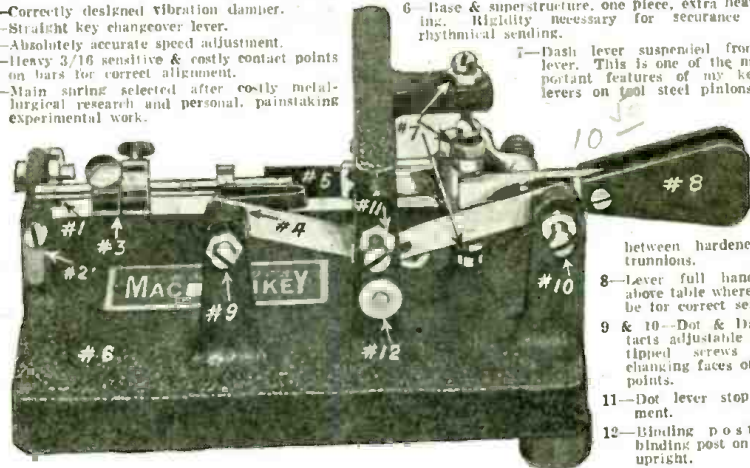

between hardened pivot trunnions.

- 8—Lever full hand width above table where it must be for correct sending.
- 9 & 10—Dot & dash contacts adjustable by fine tipped screws without changing faces of contact points.
- 11—Dot lever stop adjustment.
- 12—Binding post. Other binding post on opposite upright.

I emphatically assert that my key is the only one made with which it is possible to send perfect Continental code with its multiple dash figures and letters. Price \$17.50 f.o.b. Boston. Temporarily subject to 40% discount. Whether I can continue this customary discount depends upon volume. Take another

peek at my guarantee. Then see your local dealer or write me direct enclosing money order for \$10.50. If you think you've been enjoying ham radio heretofore, wait'll you try a Mac-Key and hear code you never dreamed yourself capable of turning out. But do it now, please. I've put my whole life into my key. Honestly, it is marvelous.

T. R. McELROY, Dept. S-2, 23 Bayside Street, Upham's Corner P. O., Boston, Mass.

Distributed in metropolitan Boston by the RADIO SHACK, 46 Brattle St., Boston
In New York by GROSS RADIO, INC., 51 Vesey Street, New York City

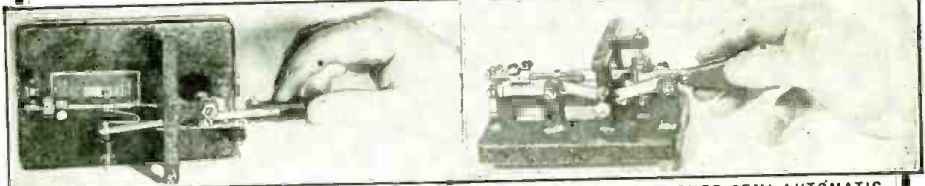

A PERFECTLY BALANCED STRAIGHT KEY

BEAUTIFULLY DESIGNED SEMI-AUTOMATIC

STOPPANI COMPASS

A Precision Instrument made in Belgium. Purchased by the U. S. Government at more than \$30.00 each. Ideal for Radio Experimenters Laboratory, also may be used as a Galvanometer for detecting electric currents in radio circuits. Ruby, jeweled, solid bronze, 4 inches square, fitted in a hardwood case.

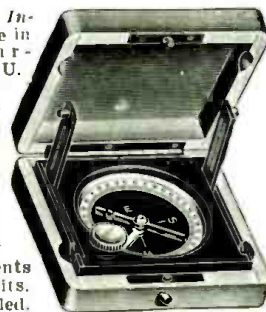

Our price prepaid \$4.50 each
Gold Shield Products Co., 98 Park Place, N.Y. City

We Carry MAC-KEYS in Stock

Price \$10.50
In fact, we always handle the most up-to-date parts for "Hams".
Write us for anything you need.
GROSS RADIO, INC.,
Dept. C., 51 Vesey St., New York City

Just Off the Press!

RADIO'S GREATEST VALUES

100 Pages. Filled with Latest Design Portable, Mobile and Rack & Panel, Public Address Amplifiers, Short-Wave and All-Wave Receivers and Converters, Inter-Office Call Systems, Test Equipment, Replacement Parts, Kits, Tubes, and Accessories—all at Unbeatable Rock Bottom Prices! Send For Your Copy To-Day!

COAST-TO-COAST RADIO CORP.
125 S. WEST 17th STREET, NEW YORK, N.Y.



BUD Presents—New

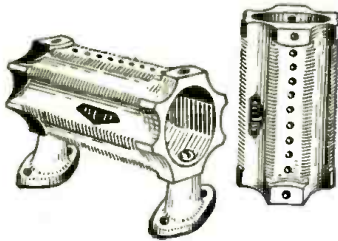

Bud Isotex Coil Forms

Suitable for 20, 40, 80 and 160 meter oscillators, amplifiers, etc. This form is threaded for No. 10 wire or smaller and drilled with sufficient holes for wires and supports. ISOTEX is a specially impregnated moulded ceramic material having exceptionally low loss properties. Size of form 3" O.D. x 6" long, and threaded for thirty-four turns of wire.

- No. 376. Coil only, no supports.....\$2.50
- No. 377. Coil with supports and hardware.....\$3.00

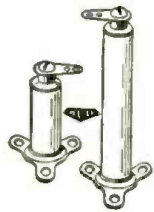

New Bud Low Loss Stand-off Insulators

Made in two sizes. This handy stand-off Insulator made of Isolantite—has a 3 point crowfoot type mounting base. Very useful in mounting transmitter inductances.

- No. 738. Length 1 3/8".....\$.25
- No. 739. Length 2 3/8".....\$.35

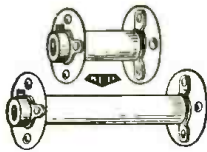

New Bud High Voltage Flexible Shaft Couplings

Insulated with Isolantite rod. Made in two sizes.

- No. 740. Length 1 3/4".....\$.90
- No. 741. Length 3 1/4".....\$1.10



New Bud Lead-in

This Lead-in has a threaded brass rod that is insulated almost the full length. It may be cut off to the proper length to fit the individual use to which it is to be applied.

- No. 742.....\$.60



BAKELITE BAR KNOBS. Pointer type. Screw mounting. 1/4 inch hole. White pin line. Two sizes furnished in either black or brown bakelite.

- No. 579. 1 1/4" Black.....\$.15
- No. 581. 2 1/4" Black.....\$.20
- No. 580. 1 1/4" Brown.....\$.15
- No. 582. 2 1/4" Brown.....\$.20

Listed above are but a few of the items in the complete BUD line. Write for New 1935 Catalog! All list prices shown in this advertisement are subject to 40% discount when purchase is made from an authorized BUD jobber. If your jobber cannot supply BUD parts, send your order direct to us together with your jobber's name and we will make shipment direct.

BUD RADIO INC. 1937 E. 55th STREET CLEVELAND, OHIO

Short Waves and Long Waves

(Continued from page 597)

of the Navy network in this country. Hope this will give your readers some impression of a British "rig."

JACK CUTHBERTSON, G5CU, Scarborough, Yorkshire, England.

(Fine, Jack, and we shall be glad to have amateur station owners as well as S.W. "listeners" in other countries write us and send along pictures of their stations.—Editor)

When to Listen In

(Continued from page 608)

most satisfactory ones. In addition they have adopted a new set of call letters for their stations. 12RO seems to have been dropped. The 49.3 m. channel, 6085 kc. which is used for the North America program at the moment is known as IRA. The station operates on 9780 kc. on Tuesday, Thursday, Saturday, and possibly Sunday, from about 2:30-7 p.m. with a program for South America and possibly Africa. The following is a list of known frequencies which have been assigned to the station in addition to those mentioned: 5555, 5610, 5660, 5725, 6065, 6160, 6980, 9600 and 9635 kc.

Davertry

For January: Trans. 1 on GSF, and GSD 3:30-5:30 a.m. Trans. 2, Sunday 7:30-9 a.m. on GSE and GSF; Weekdays 6-7:30 on GSG and GSF; 7:30-9 a.m. on GSE and GSF. Trans. 3, 9:15-10:45 a.m. on GSE and GSB; 10:45 a.m.-12:15 p.m. on GSA and GSB; 12:15-12:45 p.m. on GSD and GSA. Trans. 4, 1-3 p.m. on GSD and GSB; 3:5-4:5 p.m. on GSB and GSA. Trans. 5, 6-8 p.m. on GSA and GSC. Two new wavelengths have been assigned to Daventry, GSI, 15260 kc. and GSJ, 21530 kc. Neither are in use as yet.

Caracas

YV2RC as Caracas, Venezuela, on 6112 kc. now operates on a new schedule: Sunday, 1:30-10:30 p.m.; Weekdays 11 a.m.-1:30 p.m.; Monday, Thursday, and Saturday, 5-10 p.m.; Tuesday, Wednesday, 5-9:30 p.m.; Friday, 5-9:45 p.m.

Sydney

VK2ME at Sydney, Australia, on 9590 kc. operates each Sunday in January and February from 1-3 and 5-11 a.m.

Japan

JVT at Nazaki on 6750 kc. is now the star early morning station. It relays JOAK, a Tokyo broadcast station, every morning from about 3-7:45 a.m. It is being well received throughout the country. English news bulletins are broadcast from 4:55-5:00 a.m.

All time given is Eastern Standard Time. (Continued on page 623)

Short-Wave Chokes

(Continued from page 593)

When the cement has set firmly, but is not yet hardened, the winding should be removed from the wooden tube and the cardboard pulled out, by rolling it into a tight spiral. Finally the dampened paper should be removed, taking care not to pull too much. As the cement is waterproof, it will not stick to the wet paper, so the resulting coil will be completely supported by the cement, which is largely composed of celluloid and is an excellent insulator.

The choke thus made will be not only light in weight, but also unusually high in efficiency. The same method can be employed for winding other types of coils, but the turns must touch (be adjacent and not spaced out) or the coils will not hold together.

2 NEW Thrills for the S.W. FAN!



Lafayette TRANSCEIVER

One of the most powerful portable units ever offered in this class. Using a type 19 tube in a h.p. oscillator it has a power output of approx. 2 watts (about 10 times the power of units in this class). More than enough output is obtained for speaker operation if desired. Entirely self contained. Wgt. 26 lbs., with batteries. Price, less tubes and batteries, \$17.95. Kit of tubes, \$1.75. Set of batteries, \$3.77.



NEW STATION FINDER!

Use it with any radio! As you turn dial over exact spot where carrier wave comes in you get a loud musical tone. Throw off the station finder and there's your station! Removes all guesswork in tuning short waves! No more need to try pulling in stations through background noise! Tube type; giving 500 cycle tone. Very musical. Your cost, \$4.50 less tubes.

BE SURE TO GET YOUR COPY OF THE FREE Catalog NO. 56



FREE CATALOG

Special Pre-Inventary Bargain Supplement of 36 pages in which are listed some of the most amazing values that you ever saw! Now is the time to **SAVE MONEY**—by buying from this Bargain Book in which prices are way, way down! Address Dept. SW-25.

WHOLESALE RADIO SERVICE CO.

NEW YORK ATLANTA
100 Sixth Avenue 430 W. Peachtree St. N.W.
Local Branch 219 Central Ave., Newark, New Jersey

Please mention SHORT WAVE CRAFT when writing advertisers

DX2 All-Wave Set

(Continued from page 601)

and have a range of about 5-65 mmf. The condenser C4 is used to prevent the occurrence of noise as this control is varied. The plate resistance of the type 30 tube, being relatively low, permits the use of a small external plate resistor R3. This in turn allows the use of a rather low voltage B battery supply.

The signal output of the detector is fed into the grid of the audio amplifier by means of the coupling condenser C5, which has a value of 0.01 mf. A grid leak having a resistance of 500,000 ohms is required for the power tube. An external C battery having from 7½ to 13 volts is required for the bias on the power stage. Due to the relatively low plate resistance of the 33 power pentode, one may connect the headphones directly in the plate circuit of this tube with very good results. The high amplification factor and power sensitivity of this tube results in the production of a very satisfactory signal by this receiver.

The filaments operate from two dry cells connected in series, the voltage being reduced to the required two volts by means of the rheostat R2. If one prefers, one of the two-volt "air-cell" batteries may be used instead with equally good results. A plate voltage of 45 to 135 volts is recommended, the higher values producing the greatest volume.

An antenna having an over-all length of from 30 to 100 feet should give satisfactory results. A good ground connection is also required.

Four plug-in coils enable one to cover the wave length range of approximately 10-205 meters. Two additional coils are available which extend the wave length range up to about 600 meters, and make an all-wave receiver.

The entire receiver is mounted upon a fine, heavy metal chassis and panel, finished in black-crackle lacquer, and presents an unusually neat appearance.

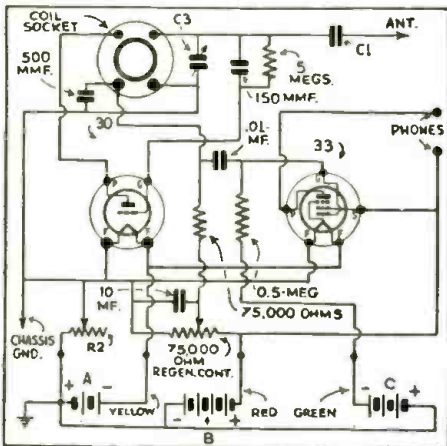

Hook-up of "DX2" All-Wave Receiver. Note that by-pass condenser marked 10 mf. should read .1 mf.

\$20.00 PRIZE MONTHLY FOR "BEST" 1-TUBE SET

Or other short-wave set article accepted and published. Send diagram first or set if you prefer.

Sets must be sent PREPAID and should be CAREFULLY PACKED in a WOODEN box!

The closing date for each contest is sixty days preceding date of issue (March 1 for the May issue, etc.). In the event of a "tie" an equal prize will be paid to each contestant so tying.

The judges will be the editors of SHORT WAVE CRAFT, and George Shuart and Clifford E. Denton, who will also serve on the examining board. Their findings will be final.

Address your entries to:

Editor, SHORT WAVE CRAFT,
99-101 Hudson St., New York City.

New Low-Loss COIL SETS and COIL FORMS by HAMMARLUND

USERS say they get more stations, louder signals and sharper tuning with these low-priced Hammarlund Coils, than with any other new Hammarlund low-loss dielectric, makes the performance of these coils the season's radio sensation. Set of four coils (4 prongs, 2 windings) for 15-270 meters, \$3.00. Set of four coils (6 prongs, 3 windings) and \$1.50 respectively. 40% discount to experimenters.

No artificial coloring to cause losses in Hammarlund "XP-53" Coil Forms. Ribbed for air-spacing. Easy-grip flanges and handy "Meter-Index" inserts for recording coil ranges. Coil Forms (4 or 5 prongs). 35c each. 6-prong forms, 40c each. 40% discount to experimenters.

Mail Coupon for Details
HAMMARLUND MANUFACTURING CO.
421-38 W. 33rd St., New York, N. Y.

Check here and attach for Hammarlund 1935 Short-Wave Manual, describing most popular circuit of past year. Check here for FREE new 1935 Catalog.

Name _____ Address _____



FOREIGN RECEPTION GUARANTEED!

The Startling Superba Model

ADVANCED engineering embodied in the new Supertone Superba seven-tube short-wave superheterodyne creates results utterly surpassing and amazing! Certainly foreign reception is guaranteed. Why not? There are two intermediate stages, a separate 56 oscillator is used, and the modulator is the most sensitive 57. The 2A6 helps maintain maximum sensitivity—tone quality preserved by linear diode detection, and amplification highly supported by the high-mu amplifier. This is a high-gain set, sensitive all the way to 20 mc, even in the region where other sets fall down.

The intermediate frequency is 465 kc. Automatic volume control minimizes fading.

Finest parts are used, including products of Hammarlund Mfg. Co., National Co., etc.

Combining engineering skill and economy resulting from quantity production, we are able to offer this world-beating receiver at a very low price.

It is no feat at all to tune in stations all over the world—even low-powered and otherwise hard-to-get stations—on the Supertone Superba, 15 to 200 meters.

The Superba is housed in a luxurious table model cabinet and is supplied complete in every respect. For 90-125 v. a.c., 50-60 cycles. The wired model, with seven tubes, eight plug-in coils (two for each band), cabinet, speaker, all in perfect condition, ready to play. **\$34.**

Wired chassis, with seven tubes, eight coils, speaker (same as above, less cabinet).....\$30.00
Complete kit, with seven tubes, eight coils, speaker, and blueprint.....25.88

SUPERTONE PRODUCTS CORP.

35 Hooper Street,

Dept. S-2 35,

Brooklyn, N. Y.

SPECIAL

FOR THIS MONTH ONLY.

Send \$1.00 (\$1.25 Canada and foreign) and we will send you SHORT WAVE CRAFT for Eight months. DO IT NOW!

SHORT WAVE CRAFT
99-101 Hudson Street New York

ANTENNAE FOR ALL WAVES

BUILT READY-TO-HANG-UP. LYNCH materials used exclusively. For suggestions and estimate, send sketch of location.

Illustrated: LYNCH Hi-Fi Duplex Cage, Giant Killer lead-in ALL WAVE Antenna System complete \$13.75.

AMPLIVOX LABORATORIES 227 Fulton St. New York City

100% Short Wave Book and it's

FREE!

Exclusively Short-Waves From Beginning to End
52 PAGES 50 HOOK-UPS 500 ILLUSTRATIONS

A Real Text Book On Short-Waves

ANOTHER GREAT EVENT! This special edition of our famous Treatise is exclusively short-wave from beginning to end. Packed between its two covers is a wealth of information covering the entire short-wave field. Every word in it is new.

This Short-Wave Treatise contains 52 solid pages of useful short-wave information, diagrams, illustrations, short-wave kinks and real live short-wave radio merchandise. It contains more valuable short-wave radio information—more real live "meat"—than many text books on the subject. Special attention has been given to the short-wave beginner. Numerous articles are devoted entirely to his interest. Yet, we have not forgotten all you ol'-timers. There is plenty of real "dope" for you too.

PARTIAL LIST OF CONTENTS

Getting Started in Short-Waves—Helpful Short-Wave Kinks—Principles of Short-Wave Converter Operation—Bandreading Explained—How to Build the "19" Unknown Triplex For Less Than \$5.00—How to Tune For Foreign Short-Wave Stations—How to "Band-spread" the 2-Tube Electrified Doerle Set—How to Build a 5 and 10 Meter Phone and C.W. Push-Pull Transmitter—How to Build a Medium Power Transmitter Using the New 203-A Tubes—All About the New Short-Wave Transmitters and Receiving Antennas—Notes on Short-Wave Operation (Effect of Time of Day and Season of Year on Short-Wave Reception)—Complete Up-to-Date Characteristics of Transmitting Tubes, etc., etc.

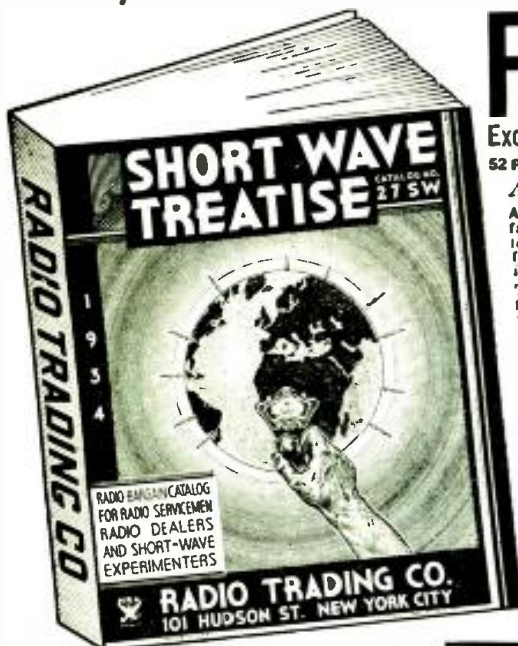

Record Foreign Programs

(Continued from page 587)

signal which will fully load up the last stage to its rated output. A careful check on the volume level should be kept while recording, for if the signal is too strong the needle will jump from one groove to another, and if the signal is not strong enough a weak record will result. A little experimentation at different volume levels and with slightly different weights on the recorder will soon show the experimenter the best arrangement. Fig. 1 shows the arrangement of the equipment for this simple recording set-up. It is important that the recorder's impedance is matched to the impedance of the output of the receiver. This can be done by several methods as illustrated in Figs. 2, 3, 4. For "playing back" the finished record, the pick-up is connected to the input of the audio system of the set (see Figs. 5, 6) a special play-back needle is inserted in the pick-up and the record is then played in the ordinary manner. No weight is used on the pickup when playing back.

Fig. 7 shows a complete set with provision made for "cutting in" the pickup for playing back and for recording.

Best System Uses Feed-Screw

A more expensive method of recording uses a feed-screw mechanism and un-grooved records. The feed-screw guides the recording head and grooves the disc while recording. This method is more satisfactory in that better quality recordings with less needle scratch are obtained. Recording can be done on either aluminum, celluloid or acetate-coated aluminum. For general use aluminum and coated aluminum are most satisfactory. These two types require entirely different types of needles for recording. Recording on aluminum requires a weight of about 10-14 ounces on the recorder, while recording on the coated aluminum requires but 1 or 2 ounces pressure. The coated record gives a higher degree of fidelity with slightly more surface noise.

When the aluminum records are played back it is necessary to use a fibre or cactus needle. The acetate-coated aluminum records require either a fibre, cactus or an acetate-steel needle for playing back. The composition records are played back with the special blunt red-shank needle made especially for them. This needle may be used for recording on the pre-proved composition blanks as well as for play-back. Figs. 8 and 9 show how a feed-screw mechanism is used for recording. In playing the finished record it is not necessary to use the feed-screw, as the record is then grooved properly. The recording head should not be used for playing back. A separate pickup is necessary for playing back. The cheapest recorder with feed-screw in the open market costs around \$25. To this must be added the cost of the pickup (unless the experimenter already has one). (Fig. 9.)

Strong Motor Needed for Recording

In all recording it is essential that the turntable motor, whether it be of the spring, electric or gravity type, should possess sufficient power to permit the turntable to revolve at a steady speed while recording. Considerably more power is required for this than in ordinary playing back of records due to the fact that the recorder is weighed down and is also forming grooves in the record. A commercially available unit consisting of a powerful electric motor and turntable, a recording head and feed-screw, a separate pickup and a volume indicating meter, all mounted in a special case is illustrated in Fig. 10. Such equipment will range in price from about \$55 to \$200.

A volume-indicating meter is a very useful and important accessory in recording. It can be in the form of a vacuum tube voltmeter (see Fig. 11) or may be a 0-1 millimeter with a small meter type oxide rectifier in series with it, together with a series resistor (see Fig. 12). The series resistor value should be near the value of the impedance of the cutting head. For

WRITE TO-DAY
RADIO TRADING CO.

Enclose five cents coin or U. S. stamps for postage — Treatise sent by return mail. PRINT NAME AND ADDRESS CLEARLY.

101A Hudson St.

New York City

The MARTIAN EAGLE **AC 6 Tube Super-Heterodyne**

"SWOOPS" ACROSS THE CONTINENTS —AND IT TAKES A SUPER TO DO IT!

Complete Kit of Parts **\$17.95**
Less tubes and Speaker
Rola Dynamic Speaker \$3.45

Set Constructed—Ready to Work, Including Speaker
Less Tubes **\$28.50**

An EAGLE All-Wave is a Round Trip Ticket for Everyone at Home. Visit Germany, England, France, Japan, China, Australia, Brazil, San Domingo, etc.

Technical Data on Both Sets—FREE on Request. Your Spare Money. Build Slowly and Carefully.

EAGLE RADIO 84 Cortlandt St., New York

Outstanding Performance Assured

EAGLE "7" ALL WAVE Matched Super-Heterodyne Kit

A perfectly matched set of Wave Band Coils, Selector Switch, I.F.'s, Packers, etc., with which you can build a powerful 7 Tube All-Wave Set or convert your present Receiver into a splendid All-Wave Super.

EAGLE \$8.95
Foundation KIT
DRILLED \$1.50
Foundation CHASSIS

The EAGLE "7" Complete Including the following: A—EAGLE Foundation Kit, B—DRILLED Foundation Chassis, C—All other requirements to complete the set—Less speaker

\$21.50

Ask about our "Pay-As-You-Build" Plan. Buy Parts with

7-POINT MIKE
FELL 20 FEET
...STILL GOOD AS EVER

... AND STILL NO FEEDBACK!
Johnston P. A. Service, Oneonta, N.Y., writes us: "We are certainly well pleased with your velocity mike (the 7-Point Mike). We believe that no other mike can take the punishment it has and still work. One time it fell 20 feet to the ground. And dozens of times it has seen rain. We use it in our mobile outfit, and it's just as good as ever. Also a wonderful help in eliminating acoustical feedback." Guaranteed. Order from your wholesaler, or write for illustrated Bulletin 72.

AMPERITE Corporation
561 BROADWAY NEW YORK

AMPERITE VELOCITY MICROPHONE

Short Wave League Members

IDENTIFY THEMSELVES WITH THE ORGANIZATION

In order that fellow members of the LEAGUE may be able to recognize each other when they meet, we have designed this button, which is sold only to members and which will give you a professional appearance.

If you are a member of the LEAGUE, you cannot afford to be without this insignia of your membership. It is sold only to those belonging to the LEAGUE and when you see it on another, you can be certain that he is a member.

See Page 636

Lapel Button, made in bronze, gold filled, not plated, prepaid..... 35c
Lapel Button, like one described above, but in solid gold, prepaid.....\$2.00

Please mention SHORT WAVE CRAFT when writing advertisers

example with a 4000-ohm recorder a 3000-ohm resistor will be found suitable. The vacuum tube voltmeter while more expensive to build is more satisfactory as it draws no current from the recorder. The oxide rectifier type on the other hand will reduce the output of the recorder when connected across it and make necessary an increase in the volume level of the amplifier to compensate for it.

Recording Needles

In recording, sapphire needles or sometimes diamond point needles are used. In recording on ungrooved aluminum a sapphire needle which makes an angle of between 25 and 28 degrees with the vertical is used. For recording on pre-grooved aluminum and composition discs, a sapphire needle with slightly duller point is used. For recording on acetate-coated and celluloid records, a very hard sapphire point (chisel point) needle, making an angle of 2 degrees with the vertical is used. These needles are supplied with bent shanks to secure the proper angle.

Details of Powerful Amplifier

For those who do not possess a sufficiently powerful amplifier for recording the circuit of a suitable amplifier with all values is given in Fig. 13. The output of the detector of the s-w. set is connected at the input of the amplifier. The recorder is connected to the output of the amplifier; in playing back the pickup is connected to the amplifier input in place of the s-w. set by a switch, and the loud-speaker is connected to the output of the amplifier. When recording, the speaker may be disconnected and a pair of headphones plugged in the phone jack of the amplifier for listening or "monitoring."

The average phonograph pickup has a high impedance and may be connected across the primary of the output transformer for recording. Some recording heads are of high impedance also and may be similarly connected. If the pickup used for recording is of the low impedance type (10 to 500) ohms, or if a low-impedance recording head is used it will be necessary to secure a matching transformer to connect the recorder to the output of the set or amplifier (see Figs. 3 and 4). If the experimenter is using a powerful receiver which requires no additional amplifier and which contains a dynamic speaker, it may be possible for him to ascertain from the manufacturer the impedance of the voice coil of the loud speaker. (This generally ranges from 1-20 ohms.) Knowing this impedance it should be possible to secure a pickup for use as a recording head, or a special recording head, whose impedance is identical to the voice coil of the speaker. If this is the case the recording head may be connected in place of the voice coil of the speaker and a perfect match secured. It should be noted in this case that the voice coil of the speaker must be disconnected while the recorder is connected, in order to obtain best results. Fig. 16 shows how to use wafer adapters for attaching or connecting recorders to pins of output tubes. (See Fig. 14.)

Short Wave Scouts

(Continued from page 595)

- lays WCAU—heard daily, in evenings.
- W3XAU—Philadelphia, Pa.—31.23 meters—relays WCAU—heard daily in afternoons.
- W8XAL—Cincinnati, Ohio—49.50 meters—relays WLW—heard in mornings and near 12 p.m.
- W8XK—Pittsburgh, Pa.—13.97 meters—relays KDKA—heard irregularly in morning.
- W8XK—Pittsburgh, Pa.—19.72 meters—relays KDKA—heard regularly in mornings.
- W8XK—Pittsburgh, Pa.—25.27 meters—relays KDKA—heard regularly at 5 p.m.
- W8XK—Pittsburgh, Pa.—48.86 meters—relays KDKA—heard daily every evening.
- W9XAA—Chicago, Ill.—49.34 meters—relays WCFB—heard irregularly on Sunday.
- W9XF—Chicago, Ill.—49.18 meters—relays WENR—heard daily every evening.
- CJRX—Winnipeg, Canada—25.5 meters—Canadian Radio Commission programs—heard evenings.

An Outstanding Short Wave Value—



New Price Standard Model \$54.50
Complete with Tubes and Dynamic Speaker Unit

Sargent 8-31 All Wave Amateur Super Het.

A high quality commercial type receiver for the amateur and short wave fan. Covers 15-250 meters, has Band Spread, Separate C.W., Oscillator, self-contained Power Supply, Halftime Selectivity, Fractional Microvolt Sensitivity.

Receives foreign amateurs and broadcasts, police calls, airplanes, commercial telegraph—everything a good short wave set should pick up. High efficiency over entire tuning range, no "dead spots,"—each receiver individually tested on actual signals, and guaranteed.

SOLD ON 5-DAY MONEY-BACK TRIAL.

ORDER YOURS TODAY

We are glad to quote you price on an 8-31 for operation on any A.C. or D.C. voltage or on batteries. Write.

"Round-The-World 3"

Complete 3 tube Short Wave Set, wired for A.C. operation, including tubes, plug-in coils and headphones \$16.50 net. Covers 15-200 meters—Nothing else to buy. Write.

Marine Model 8-34

For only \$8.00 extra, \$62.50 complete, we can supply the Marine Model 8-34 Receiver. This covers all wavelengths from 15 to 1500 meters. Gets the ship waves and airplane beacons in addition to usual "All-Wave" features.

Price Announcement

Continually rising prices of material have forced us to raise the price on the 8-31 Receivers. These new prices are effective Jan. 1st. At the new price the 8-31 is still 30% lower than other sets that give approximately equal performance. It is the greatest value on the short wave market.

No New Model

Hundreds of 8-34s sold to enthusiastic users everywhere is our best answer to those who inquire whether we will be putting out a "35" model soon. The 8-34 has been so satisfactory that there will be NO NEW MODEL. The 8-34 is our "35" model and will stand without change throughout the entire season.

E. M. Sargent Co.
212 Ninth St., Oakland, Calif.

Short Wave League Letter-heads

Designed for Members



This is the official letterhead

It is invaluable when it becomes necessary to deal with the radio industry, mail order houses, radio manufacturers. It can be used in many ways and gives you a professional standing. No member of the LEAGUE can afford to be without this letterhead.

This can only be used by members of the LEAGUE. No one else can purchase it.

See page 636 of this issue for order blank. Take advantage of this opportunity to handle your LEAGUE correspondence in a business-like manner.

SHORT WAVE LEAGUE
99-101 Hudson St., New York, N. Y.

When It's Needed in a Hurry!

Servicemen—Amateurs—Experimenters
Depend on
BURSTEIN-APPLEBEE CO.
America's Largest Radio House
in America's Handiest Shipping Point.
1012-A McGee St., Dept. 132
Kansas City, Mo.

1935 Catalog
148 Pages
Write us if you haven't a copy.

Learn CODE The CANDLER Way PRACTICE EQUIPMENT Furnished FREE With SCIENTIFIC CODE COURSE

Complete Training in Code, Radio Fundamentals and Theory to enable you to pass the Exam., build your own station and operate it.

All skilled amateurs and com'l ops will tell you CANDLER Training is the best that can be had, and that our students read fast press and traffic as easily as they read a newspaper, and copy behind with "infill" or pencil.

FREE—CSCG SCHEDULE, listing all CSCG stations broadcasting daily practice programs from every district. Listen to CANDLER trained ops on your s-w. receiver.

"Work your former student, Watson, Chief Op. BEAR OF OAKLAND, WHEW, every night. One of finest ops I ever worked. We hit up to 45wpm right along. I work Candler men in all parts of world. They're fast—plenty! CANDLER COURSE best investment I ever made."
73. L. S. HENDERSON, Op., KFS, M.R.T. Half Moon Bay, Calif.

CANDLER signed GUARANTEE (not promise) protects you. Money back if you "Dunk"

Get your training where the champions and world's fastest ops got theirs. Small cost, easy payment plan. FREE BOOK OF FACTS gives details. A card will bring it.

CANDLER SYSTEM Co. Dept. 9-2
6343 S. Kedzie Ave., Chicago



THE BEST IS NONE TOO GOOD

The Trimm Featherweight is not a common headphone. It is a scientifically developed and precision built product.

We specialize in solving unusual applications. Let our engineers know your headphone problems. We have a model to meet each need.

TRIMM RADIO MFG. CO
Dept. SW-2-35
1528 Armitage Avenue Chicago, Illinois



2 new BOOKS on SHORT WAVES

HERE are two brand new books which you have been looking for for a long time. They contain everything that you have been asking for for many months. These new books will give you the latest information of everything you wish to know in two respective fields. Be sure to order them today. You will not regret it.

They make excellent companions to our other handbooks, which you may have.

7" x 10"

"How to Get Best Short Wave Reception"

By M. HARVEY GERNSBACK

Here is a book that gives you everything you have ever wanted to know about short-wave reception.

The author, a professional radio listener and radio fan for many years, gives you his long experience in radio reception and all that goes with it.

Why is one radio listener enabled to pull in stations from all over the globe, even small 100 watters, 10,000 miles away, and why is it that the next fellow, with a much better and more expensive equipment, can only pull in the powerful stations that any child can get without much aid?

The reason is intimate knowledge of short waves and how they behave. Here are the chapters of this new book:

1. What are Short Waves and what can the listener hear on a short-wave receiver or converter?
2. How to tune and when to listen in on the short waves.
3. How to identify short-wave stations.
4. Seasonal changes in short-wave reception.
5. Types of receivers for short-wave reception.
6. Aerial systems for short-wave receivers.
7. How to get verifications from short-wave stations.
8. Short-wave hints.

The book is profusely illustrated with the best kind of illustrations that it was possible to obtain.

Please note that this is not a re-hash of anything that has appeared before. Everything in the entire book has been written to order, and there is no duplication of anything here that has appeared in print before.

The book will make excellent reading matter, whether you are a rank beginner or whether you have been at it for a long time. There are many tricks in short-wave reception that even some of the "old-timers" do not know. That is the reason for this book. Be sure to get it.

Place your order at once. **50c**
72 pages, over 40 illustrations.
Price

101 SHORT WAVE HOOKUPS

Compiled by the Editors of SHORT WAVE CRAFT

Here is a worthwhile book that every short-wave listener, every short-wave fan, and every short-wave amateur has wanted for a long time. It gives you the 101 best short-wave hook-ups which have appeared heretofore. It is a veritable encyclopedia of the best in short-waves when it comes to hook-ups.

And do not run away with the idea that we just give you a few plain hook-ups. Each and every hook-up and diagram illustrated is also accompanied by a thorough explanation of what this particular hook-up accomplishes, what parts are required, odd-winding information, values of resistors, etc. In fact, everything you want to know in order to build the set or to look up the data required.

To be sure, all of the important sets which have appeared in print during the past five years are in this valuable book. Sets such as the Doerle, Dinsmore, the "19" Twinplex, Oscillodyne, Duo-Appidyne, Denton "Stand-by," Megadyne Triplex 2, "Globe-Trotter," 2-Tube Superhet, Minihyline, "Loop" Receiver, "Doerle" 2-tube Battery, "Doerle" 3-tube Battery, "Doerle" 2-tube A.A., "Doerle" Band-Spread 2-tube Receiver, "Signal Gripper," "Unifrol" Band-Spread 2-tube Receiver, 3 Meter Portable Transmitter and Receiver, Duo H.F. 4-tube Receiver, The Sargent 9-33 Tapped Coil Receiver, Globe-Girdler 7, The 2-Tube "Chanup," 2 Tubes Equal 3, Ham-Band "2-tube Pee-Wee," Wyeth All-Wave 6, "Rex" Portable Super-het Receiver, The "53" 1-tube Twinplex, Stuart Band-Spread S.W. Converter, The "Ace" Band-Spread 3, Denton Economy 3, 2-Tube "Regenerative-Oscillodyne" will be found here, with full descriptions. In many cases, where it was necessary, we have also included a picture hook-up for those who do not wish to follow the regular symbolic hook-up, but wish to have a regular wiring diagram.

Also note, that in many cases, we have not just reproduced old hook-ups or diagrams. In many cases they have been brought up-to-date, to give you the latest information available in such sets.

This is a very handy volume, especially for those "fans" who wish to study the best sets in the short-wave art, from one tube up to ten tubes, instead of leafing through a dozen magazines and going through back numbers.

The present volume brings you everything in a clarified manner, leaving nothing to your imagination. The book is thorough, and up to date, and will be a welcome addition to your radio library.

72 pages, over 100 illustrations. **50c**
Price

- CJRO—Winnipeg, Canada—48.85 Meters—Canadian Radio Commission programs—evenings.
- VE9GW—Bowmanville, Ontario—49.22 meters—Canadian Radio Commission programs—evenings.
- KWU—Dixon, Cal.—19.45 meters—phone to Japan and Java—heard regularly evenings.
- KWO—Dixon, Cal.—19.54 meters—phone to Japan and Java—heard in evenings.
- TIEP—San Jose, Costa Rica—44.52 meters—"La Voz Del Tropica"—daily 6-10 p.m.
- W1XAL—Boston, Mass.—25.35 meters—relays station WEEL—heard very irregularly.
- WEL—Rocky Point, N.Y.—33.52 meters—tests with Europe in evening.
- WEA—Rocky Point, N.Y.—28.73 meters—relays broadcasts to Europe.
- W2XBJ—Rocky Point, N.Y.—87.55 meters—tests with KJTY.
- WET—Rocky Point, N.Y.—31.70 meters—tests with Schooner "Seth Parker."
- KNRA—Schooner "Seth Parker"—33.48 meters—heard every Wednesday evening at 8 p.m.
- WNC—Hialeah, Florida—19.91 meters—phone to Colombia—mornings, daily.
- WLL—Rocky Point, N.Y.—17.73 meters—phone to Europe—experimental.
- WDN—Rocky Point, N.Y.—73.81 meters—tests with Schooner "Seth Parker."
- WEJ—Rocky Point, N.Y.—6470 kilocycles—relays messages from Europe.
- WES—Rocky Point, N.Y.—9450 kilocycles—tests with Byrd Expedition.
- WQV—Rocky Point, N.Y.—14500 kilocycles—tests with RKI and RNE Saturday a.m.
- WQO—Rocky Point, N.Y.—6725 kilocycles—tests with Schooner "Seth Parker."
- WQP—Rocky Point, N.Y.—13900 kilocycles—tests with Russia each Saturday a.m.
- WCG—Rocky Point, N.Y.—10380 kilocycles—tests with Schooner "Seth Parker."
- WEM—Rocky Point, N.Y.—7400 kilocycles—relays broadcasts from Europe.
- WEF—Rocky Point, N.Y.—9490 kilocycles—used in Byrd Expedition broadcast.
- WKU—Rocky Point, N.Y.—14830 kilocycles—used to rebroadcast from Europe.
- WKK—Lawrenceville, N.J.—14.01 meters—phone to stations in South America.
- WOO—Lawrenceville, N.J.—17.52 meters—phone to Europe—early mornings.
- WLM—Lawrenceville, N.J.—18.44 meters—phone to England—early mornings.
- WLK—Lawrenceville, N.J.—18.44 meters—phone to England—forenoon.
- WNA—Lawrenceville, N.J.—9163 kilocycles—phone to England—evenings.
- WNB—Lawrenceville, N.J.—10675 kilocycles—phone to Bermuda—afternoons.
- WKF—Lawrenceville, N.J.—19220 kilocycles—phoning South America in afternoon.
- WOA—Lawrenceville, N.J.—6775 kilocycles—phoning Europe in evening.
- WOB—Lawrenceville, N.J.—5855 kilocycles—phone to England.
- WNK—Lawrenceville, N.J.—16697 kilocycles—phone.
- VK3LR—Melbourne, Australia—31.35 meters—Weekdays 3 to 8 a.m.
- DJB—Berlin, Germany—19.73 meters (15200 kc.)
- DJD—Berlin, Germany—25.51 meters (11760 kc.)
- DJA—Berlin, Germany—31.38 meters (9560 kc.)
- DJC—Berlin, Germany—49.83 meters (6020 kc.)

Trophy Contest Entry Rules

● THE rules for entries in the SHORT WAVE SCOUT Trophy Contest have been amended and only 50 per cent of your list of stations submitted need be verified. If, for example, you send in a list of 100 stations with 50 verification cards, you will receive credit for the other 50 per cent or 100 stations total. The trophy will be awarded to the SHORT WAVE SCOUT who has logged the greatest number of short-wave stations during any 30 day period; (he must have at least 50 per cent verified) this period need not be for the immediate month preceding the closing date. The complete list of rules appeared in the August issue of this magazine.

In the event of a tie between two or more contestants, each logging the same number of stations (each accompanied by the required 50 per cent verified) the judges will award a similar trophy to each contestant so tying. Each list of stations heard and submitted in the contest must be sworn to before a Notary Public and testify to the fact that the list of stations heard were "logged" over a given 30 day period, that reception was verified and that the contestant personally listened to the station announcements as given in the list.

Only commercial "phone" stations should be entered in your list, no "amateur" transmitters or "commercial code" stations. This contest will close every month or the first day of the month, by which time all entries must be in the editors' hands in New York City. Entries received after this date will be held over for the next month's contest. The next contest will close in New York City, February 1.

The judges of the contest will be the editors of SHORT WAVE CRAFT, and their findings will be final. Trophy awards will be made every month, at which time the trophy will be sent to the winner. Names of the contesting SCOUTS not winning a trophy will be listed in Honorable Mention each month. From this contest are excluded all employees and their families of SHORT WAVE CRAFT magazine. Address all entries to SHORT WAVE SCOUT AWARD, 99-101 Hudson Street, New York City.

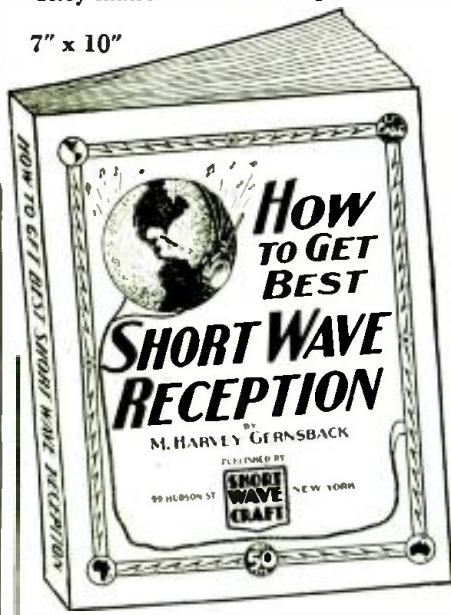

TWO BRAND NEW BOOKS WHICH EVERY ALERT SHORT-WAVE FAN SHOULD HAVE IN HIS LIBRARY

7" x 10"

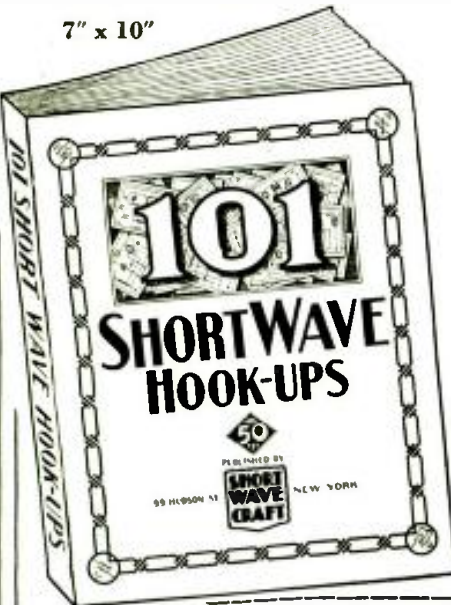

SHORT WAVE CRAFT, 99 Hudson Street, New York City.

Gentlemen:
I enclose \$ for which you are to send to me, postpaid, immediately upon publication, the books checked below:
"How to Get Best Short Wave Reception"
"101 Short Wave Hookups"

Name

Address

City and State

(Send check or money order. If you send cash or uncancelled U. S. Postage Stamps, register it.)
SWC-2-35

Please mention SHORT WAVE CRAFT when writing advertisers

Short-Wave Scout News

(Continued from page 594)

meters, week day except Sunday, 3-7:30 a.m. and 8 a.m., often from 8-9:30 a.m.; Victoria, VK3LO, relay programs through VK3LR, and is a sister station to VK3LR, (irregular) Victoria, VK3AW, 31.31 meters, "His Majesty's Guard Band," relay through VK3ME, and sister station to VK3ME—often on its own; irregular as yet, heard Sunday 5-7:30 a.m. Melbourne, VK2MC, 31.28 meters, Sunday 1-3 a.m., 4:30-8:30 a.m., 9-11 a.m.; Wednesday and Saturday, 5-7 a.m.; Melbourne, VK3ZX, 42.83 meters, Sunday 5-7 a.m.

This post will receive verification on all but VK3ME-VK2ME, which I have now. There are no short-wave stations in Perth, Australia. Receiving my *Western Australia Wireless News* magazine from Perth tells me so; this magazine was sent to this post by a good friend, Mr. Harry Jackson of Leederville, Australia. But here are a number of B.C. stations for that 11 tube DX-er. Try for them! they are on the air any evening from 7 to 12 midnight, E.S.T. Here they are:

- 6WF, 435 meters, 690 kc., 3500 watt.
- 6PR, 341 meters, 880 kc., 500 watt.
- 6AM, 275 meters, 1090 kc., 500 watt.
- 6ML, 264 meters, 1135 kc., 500 watt.
- 61X, 204 meters, 1170 kc., 300 watt.

Report from H. W. Hansen, South Omaha, Nebraska

● RECEPTION between 40 and 50 meters has shown a great improvement during the first two weeks of November, with the 19-meter band coming in the best during the daytime.

Many new South American stations have been heard that could not be identified here.

A new European signal to reach this listening post with good volume is 2RA in Rome, Italy. This station broadcasts on about 30.5 meters and was first heard here on Monday, Oct. 29, 6:30 to 7:10 p.m., C.S.T. All announcements were in English. This station was again picked up on Monday, Nov. 5, from 6 to 6:30 p.m. C.S.T. The last several weeks this station has been heard broadcasting on the same wavelength around 4 p.m. C.S.T.—Harold W. Hansen, Rt. 5, Box 169, South Omaha, Nebraska.

Heinie Johnson's "Listening Post" Report

● TO hear all stations well would require one to move their receiver all over the nation. You have probably heard CNR on 28 meters during November, as well as

TIEP on 44 meters, and the wonderful new NIROM station (Bandoeng, Java) on 49 meters.

And speaking of tricky ones to figure out, the Peru signal on 50 meters is sometimes DUSA and sometimes OA4B—same announcer.

DJN is the call of a new German signal ushered in on 31-meter band during November. Pretty good too!

If you wish to hear HIX on close to 50 meters at their best and the Jap on 44 meters, when most enjoyable, you'll do well to listen at or around 3:30 to 5 a.m. Sunday mornings and if you like Cuban signals try COH on about 32 meters in late afternoons—all Central Standard Time.—Heinie Johnson, Big Spring, Texas.

O.L.P. from Edward M. Heiser, Brecksville, Ohio

● RECEPTION at times during the past month has been comparable to summer reception in that there has been quite a bit of static.

On evenings when Germany and England were coming in very loud on the 49-meter band, the South American stations could hardly be heard. On other evenings, they all came in well. There is a new Cuban station, COH, operating on about 31.8 meters which has been coming in well. The new Rome transmitter was heard on about 49.2 meters and came in very loud. There is a bad heterodyne whistle though, which spoils their program. The call used is IRA.

DJC on 49.83 meters is coming in again as they used to, because I believe the Mexican station has moved their wavelength a little higher, just below COC.

Since winning the *SHORT WAVE SCOUT Trophy*, I have received many letters from those who built the *Tetradyne* set. One set was built by a "fan" in New Bedford, Mass., but he could not get any stations on the short-wave bands, so he sent the set to me to see if it could be made to "perk." The necessary changes were made in the set and the following stations were tuned in over a period of a few days: W1XAZ; COH; EAQ; PRF5; WNC; FYA on 19 and 25 m.; HJY; DJB; GBS; KWK; GSD; KKP; CGA4; YV3RC; GSA; DJC; COC; W1XAL; HJ1ABB; W2XE; WQO; YV5RMO; VE9GW; W8XAL and IRA.

YV5RMO was heard one evening on the wave used by YV4RC.

I am enclosing a log of stations heard during the past month.—Edward M. Heiser, Brecksville, Ohio.

Short-Wave Log—Time is Eastern Standard

Date	Time	Call	W.L.	Location	Remarks
Oct. 25	7:20 P.M.	TIEP	44.75	Costa Rica	Very Loud at Times
Oct. 25	7:10 P.M.	HJ3ABD	40.54	Bogota, Col.	Very Steady and Loud
Oct. 31	7:05 P.M.	CGA4	32.00	Dr'm'd'le, Ont., Can.	Working GCB
Nov. 1	3:00 P.M.	GSD	25.53	Daventry, Eng.	Exceptionally Loud
Nov. 1	3:10 P.M.	FYA	25.26	Paris, France	Could Just be Heard
Nov. 1	3:25 P.M.	LSX	28.98	Buenos Aires, Arg.	Special Musical Program
Nov. 1	4:00 P.M.	GSB	31.50	Daventry, Eng.	Loud but Terrific Static
Nov. 1	5:35 P.M.	PRF5	31.58	Rio Janeiro, Braz.	Fair, Heavy Static
Nov. 5	10:00 A.M.	FYA	19.68	Paris, France	Exceptionally Loud and Clear
Nov. 5	10:30 A.M.	DJB	19.73	Zeesen, Ger.	Exceptionally Loud and Clear
Nov. 5	10:45 A.M.	W8XK	19.72	Pittsburgh, Pa.	Best this Station Ever Heard Here
Nov. 5	11:05 A.M.	ZFB	29.84	Hamilton, Bermu. Is.	Working N. Y.
Nov. 5	11:15 A.M.	W3XAL	16.87	Bound Br'k, N. J.	Just Understandable
Nov. 5	2:20 P.M.	HJY	16.5	Bogota, Col.	Working CEC
Nov. 5	2:55 P.M.	ORK	29.04	Ruys'ede, Belg.	Good, but Static. No Static in A. M.
Nov. 5	8:00 P.M.	KKZ	21.91	Bolinas, Cal.	Working Honolulu
Nov. 5	8:20 P.M.	COH	31.80	Havana, Cuba	Came in Very Loud. New Station.
Nov. 5	8:40 P.M.	KNRA	33.5	Seth Parker	Very Loud and Steady
Nov. 5	9:10 P.M.	COC	49.92	Havana, Cuba	Very Loud
Nov. 6	5:45 A.M.	VK3LR	31.31	Melbourne, Aust.	Good. Logged Whole Program
Nov. 6	3:45 P.M.	ORK	29.04	Ruys'ede, Belg.	Very Good. Slight Fading
Nov. 7	8:30 P.M.	COH	31.80	Havana, Cuba	Very Good
Nov. 7	8:45 P.M.	HJ5ABD	46.40	Call, Col.	Fair, but Faded
Nov. 11	7:20 P.M.	WET	31.67	N. Y.	Working LSX
Nov. 11	7:45 P.M.	HC2RL	45.00	Guayaquil, Equad.	Fair, but Lot of Static
Nov. 11	7:55 P.M.	DJC	49.83	Zeesen, Ger.	Fair. No Interference
Nov. 20	5:00 P.M.	COH	31.80	Havana, Cuba	Very Loud
Nov. 20	5:05 P.M.	CGA4	32.00	Dr'm'd'le, Can.	Working GCB
Nov. 20	5:20 P.M.	PRS1	31.58	Rio Janeiro, Braz.	Very Clear and Loud
Nov. 23	8:00 P.M.	Germany and England	Very Loud.	South	Americans Very Weak
Nov. 26	10:15 A.M.	HJY	16.5	Bogota, Col.	Testing
Nov. 26	10:25 A.M.	FYA	19.68	Paris, France	Fair
Nov. 26	10:30 A.M.	DJB	19.73	Zeesen, Ger.	Just Understandable
Nov. 26	10:35 A.M.	KWK	Bolinas, Cal.	Working KAZ
Nov. 26	1:35 P.M.	KKP	18.25	Kohuku, Hawaii	Working, CAL.
Nov. 26	7:30 P.M.	IRA	49.2	Rome, Italy	Very Loud

NATIONAL XR-20 COIL FORMS

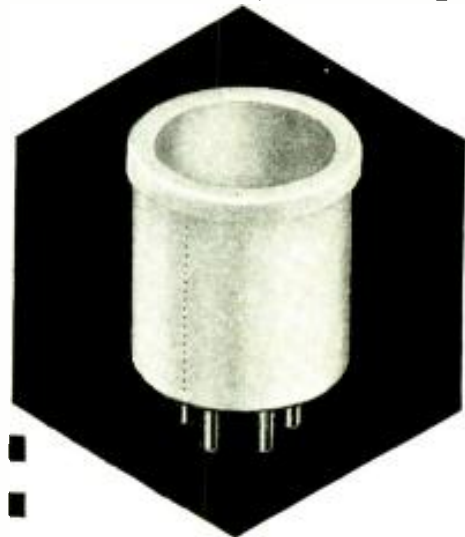

For short-wave receiver construction and experimental work when a small coil form at a low cost will fill the requirements. The XR-20 Coil Forms are made of Steatite, well known Low Loss National Dielectric. They are drilled for leads and left unglazed to provide a tooth for coil dope. Diameter 1 1/2". Made with 4, 5 or 6 prongs and fit Standard Coil-Sockets. List Price, XR-20, \$.35.

NATIONAL R-39 COIL FORMS. Machinable and drillable because made of R-39, outstanding exclusive National Dielectric. Length 2 1/4". Diameter 1 1/2". In 4, 5 or 6 prong types. List Price, XR-4, XR-5 or XR-6, \$.75 each.

List prices subject to 40% discount when purchased through an authorized NATIONAL Distributor.

USE COUPON BELOW

COUPON

National Company, Inc.
Malden, Massachusetts

Gentlemen:
Please send me your new catalogue No. 240. I enclose 6c to cover mailing costs.

Name

Address

.....

SWC-2-35

Please mention SHORT WAVE CRAFT when writing advertisers

Most Amazing TYPEWRITER BARGAIN

10 DAY FREE TRIAL OFFER EVER OFFERED

NEW REMINGTON PORTABLE only

10¢ A DAY

FIRST TIME! Remington's new purchase plan lets you buy a genuine Remington Portable No. 5 direct from factory for 10¢ a day. Not used or rebuilt. Not incomplete. A beautiful brand new regulation Remington Portable. Standard 4-row keyboard, standard width carriage, margin release on keyboard, back spacer, automatic ribbon reverse; every essential feature found in standard typewriters.

With your machine we send you free a 19-page course in typewriting. Teaches touch system quickly, easily. Soon you dash off letters quicker than with pen and ink. You also get a handsome, sturdy carrying case free.

FREE Typewriting Course

BIG PRICE REDUCTION

The amazing low price and easy terms make this the greatest typewriter value ever offered. But everything points to higher prices. Present big price reduction cannot be guaranteed long. So we say, "Act Fast!"

FREE Carrying Case

You Don't Risk One Cent

Try this typewriter in your home or office on our 10-day FREE TRIAL OFFER. Then, if you do not agree that it is the finest portable at any price, return it at our expense. You don't even risk shipping charges. Don't wait. Mail coupon now. It's the best chance you've ever had to own so complete a machine for so little money. So act NOW!

CLIP COUPON NOW

Remington Rand Inc., Dept. 214-2
Buffalo, N. Y.

Please tell me how I can buy a new Remington Portable typewriter for only 10¢ a day. Also enclose your new catalog.

Name _____

Address _____

City _____ State _____

ONE CENT A DAY PAYS UP TO \$100.00 A MONTH

The Sterling Casualty Insurance Co., 256 Insurance Center Bldg., Chicago, Ill., is offering a NEW accident policy that covers every accident. Pays up to \$100 a month for 24 months for disability, and \$1,000 for death for 1¢ a day—only \$3.65 a year. A NEW policy issued by an OLD company that has already paid more than \$175,000.00 in cash benefits. Open to any one, ages 10 to 70, without doctor's examination. They will send you a policy for 10 days' FREE inspection. Send no money. Just mail them your age and beneficiary's name and relationship. This offer is limited. Write today.—Advertisement.

MANY VALUABLE ARTICLES have appeared in past issues of SHORT WAVE CRAFT Send Us 3c for Complete Index

New Type Molded Resistors

(Continued from page 602)

tions. First, instead of a background material of very high insulating value, they substituted a background material which was in itself a resistance material. To vary this material and to get the desired resistance values, another resistance material of lower value is introduced. The entire mass, after it has been reduced to absolute uniformity, is then subject to tremendous pressure and under such pressures extruded into rods.

Consider then the result. Instead of a very small percentage of the cross-section being of a current-carrying material (as is the case with coated or film types), the entire cross-section is current carrying. Further, the cross-sectional area is not composed of a great number of voids and a relatively small number of points of contact, but is microscopically one solid uniform compact current carrying mass. This is the result of the tremendous pressures, the method of extruding, and the composition of the material itself. From the micro-photographs of these units, the results show an absolutely solid structure unlike the craters and pitted surfaces illustrated by the micro-photographs of competitive units. In fact, the new Lynch units are so uniform that they resemble the micro-photographs of a sound section of a steel gun forging. The current-carrying area is large and non-microscopic, and this in itself explains many other results as shown in the succeeding paragraphs.

A study of these units under mechanical loads, shows that resistance value remains constant. This is a most significant fact. Microscopic study under normal and excessive wattage shows that "light" points, or points of excessive microscopic current density do not exist.

The ends of the resistor are coated with fine particles of metal; next there is placed on the end of the resistor and over this metal-coated surface a solid piece of metal in the form of an end cap, to which end cap was integrally attached the pig-tails.

All test loading was applied initially at double wattage, with no effect on the value of the unit. Increased load was applied in the presence of elevated temperatures, still the units were able to show no change in value. Tests were made on an intermittent basis and the loads were varied from less than normal load to more than double load. Tests were carried out by many different groups, and were found to be highly satisfactory.

One of the most recent tests shows that not a single unit dropped in value under various loads up to double wattage and voltage up to 880 volts and greater. Variation of load of any one unit was less than 2%, but the majority of the units were fractions of 1%.

Short Waves Call Firemen

(Continued from page 583)

without alarming the whole population of the town. The fire engine in the French case is also equipped with a short-wave transmitter so that reinforcements can be summoned when necessary. In this case it simply requires that a short-wave receiver, tuned to a pre-determined frequency, be installed in the fire headquarters of the adjacent towns or different quarters of the city.

New 5-Meter Beam Antenna

(Continued from page 602)

The lower extremities of the reflector rods can be adjusted with relation to the lower extremity of the radiator rods by means of the small locking collar immediately above the insulator. The correct distance between the radiator rods and the reflector rods may be obtained by the simple operation of sliding the rear wooden support back and forth on the cross members.

NOW YOU WON'T HAVE TO SHOP FOR S. W. COILS

Because the popular-priced Na-Ald coils have not been increased in price yet they now have Vietron "AA" insulation on the lowest wave coil. Special Na-Ald Processed Low-Loss Synthetic for the other three and all windings treated with Liquid Vietron Coil Dope.

All coils listed below are boxed with diagrams and directions and use 140 mmf. size condenser.

Each of the following three S.W. Coil Sets (13 to 200 meters) have 3 coils wound on the special Na-Ald Processed Synthetic Molded Forms and the fourth coil—13 to 31 meters—is wound on VICTRON "AA", the ultimate in low-loss insulation. Precision-wound coils with convenient color-coded grip-rim for easy insertion and removal from socket.

- 704SWS 4-pln Coils.....List \$2.00 set
- 705SWS 5-pln Coils.....List \$2.50 set
- 706SWS 6-pln Coils.....List \$3.50 set
- Set of 2 Coils for 100-550 meters.
- 704BCS 4-pln Coils.....List \$1.50 set
- 705BCS 5-pln Coils.....List \$1.75 set
- 706BCS 6-pln Coils.....List \$2.00 set
- Band Spreading Coils with ceramic padding condenser mounted on each coil. Simplifies tuning. Spreads stations.
- 705SWB-20-40-80-160 m. Amateur Coils.
- 705SWBC-19-25-31-49 m. S.W. B.C. Coils. List price \$4.00 per set, \$1.00 per coil.
- Long Wave Coils for S.W. Sets using 140 mmf. and 4-prong Coils.
- 704LW1 450-900 meters.....List \$1.00
- 704LW2 940-2000 meters.....List \$1.00
- 704LWS Set of 2 Coils.....List \$2.00 set

Now you can get the Extra Value of the Na-Ald Processed Synthetic Molded Coil Forms at these new low prices. 1 1/2" dia x 2" winding space. Color-coded grip-rim—red, yellow, green and blue.

No. Prongs	List price	No. Prongs	List price
704 4-pln	20c EACH	707 5-pln	30c EACH
705 5-pln		707A 7-sm	
706 6-pln		708 8-pln	

Pop up your weak signals by using coils wound on the ultimate in low-loss insulation.

NA-ALD VICTRON "AA" COIL FORMS
List price \$1.00

Use Liquid Vietron Coil Dope on your regular coil forms as well as on Vietron.

No. LV2 LIQUID VICTRON Coil Dope.....List price 35c can

Here is the NEW Acorn Tube Socket Insulated with genuine Na-Ald Vietron "AA" Standoff construction. Alignment post prevents incorrect insertion. Sheet giving various methods of use supplied with each socket.

No. 4955V Acorn Tube Socket.....\$1.25

Here is the new Na-Ald VICTRON Insulated R.F. Choke Coil with five tapered universal wound cores on a VICTRON form which can be rigidly mounted thus preventing wobbly signals from vibration. Small pie at "hot" plate end of choke for reduced capacitance. Use this choke in all applications and enjoy its greater efficiency. D.C. resistance 30 ohms. Inductance 2 1/2 m.h.

No. 702R—Na-Ald VICTRON R.F. Choke. \$.70
List Price

The New Na-Ald Condenser Insulated with Vietron "AA" whose p.f. at r.f. is only 0.0002. Silver pressure contact on rotor. No grease or film or oxide skin as in bearing contacts. Self centering, self tightening cone bearing cannot loosen or produce noise. Minimized metal gives extremely low minimum capacity. Most practically shaped plates for station separation. Soldered brass plates precision spaced. 140 mmf. max. cap. Universal mounting. Two double solder tabs.

No. C-140 Na-Ald VICTRON "AA" Insulated S.W. Condenser.....\$2.50
List price.....

Here is the new Alden Vernier Dial. Easy to mount, operate and read. Has airplane type face with double pointer, 10 to 1 knob ratio, 40 to 1 lever ratio. Has both fine and coarse graduations. No. 300 Vernier Dial.....\$1.25
List price.....

Now 700 COIL SELECTOR takes any four 4, 5 and 6 prong coils for selection by turning knob. Mounts on chassis and panel. Modernizes old sets—eliminates handling and storing coils. Simple—compact—rugged—highly efficient—reliable self cleaning pressure contacts. Without coils.

No. 700 List price \$3.50

No. 700V NA-ALD VICTRON "AA" Insulated Coil Selector.....List Price \$7.50

No. 700CPL Complete Coupling Hardware for ganging No. 700 Coil Selectors in tandem.....List price 25c

Be sure to send for new 16 page catalog listing new items, including S.W. VICTRON Parts. When writing, include the name and address of your parts supplier.

ALDEN PRODUCTS CO.
Dept. SW 2 BROCKTON, MASS.



5-Meter Transceiver "Kit"!

(Continued from page 602)

and 27 types may also be used in the A.C. model.

If we push the transmit-receive switch to the "receive" position, the 30 tube acts as a self-quenching super regenerative detector. It is called "self-quenching" because it supplies its own low-frequency oscillations, which in other types of circuits are produced by a separate tube with an attached oscillator coil. The oscillation at low frequency is a function of the grid-leak value, in this case 250,000 ohms.

The signals received by the detector are conducted through the switch to the upper primary winding of a special double-primary audio transformer, which in the "receive" position of the switch acts as a perfectly normal A.F. amplifying transformer. The secondary goes to the 33 output tube, and the amplified signal finally reaches the earphones through an output transformer.

Now, if we push the switch to the "transmit" side, the same tubes and parts act altogether differently. With a 10,000-ohm grid-leak in the circuit, the 30 tube becomes a straight-forward R.F. oscillator, the frequency of its output depending, of course, on the setting of the 15 mmf. mid-

et tuning condenser. The lower primary of the special transformer is cut into the microphone circuit, and the transformer becomes a modulating transformer. Likewise the 33 tube, which is still connected to the secondary of the latter, becomes a regular Heising type modulator, and modulates the R.F. output of the 30 oscillator with the speech picked up by the hand microphone attached to the transceiver. The phone circuit is opened in the "transmit" position, so the primary of the output transformer functions as a straight audio choke. The principle of Heising plate modulation has been used for years and is described in detail in all radio textbooks.

The carrying case is made of two pieces: an L-shaped front and bottom, and a complete cover. The latter has two holes in the top for the stand-off insulators that carry the antenna connections, and an opening in the back for the binding post strip. Detailed assembly directions and picture wiring diagrams are supplied with the kits, and anyone who can handle a screwdriver, soldering iron and pair of pliers can put together a complete outfit in a single evening.

When to Listen In

(Continued from page 616)

Brazil

The identity of PSK, PRA3, PRF5 et al is now cleared up. The transmitters of these stations are operated by the Companhia Radio Internacional de Brazil. The transmitters are located at Marapicu near Rio. They are ordinarily used for commercial phone service to the United States, Argentina, and Spain. Six wavelengths are used: PSA on 21080 kc., tel. to N.Y.; PSF, 14690 kc., tel. to Arge. and Spain; PSE, 14935 same as PSF; PSH, 10220 kc., tel. to Spain; PRF5 9500 kc., special broadcast programs and PSK, 8185 kc. telephone service and also special broadcasts to Argentina at night. PSK sometimes relays PRA3, long-wave station in Rio. The power of the transmitters is 60 kw. each! All reports of reception should be sent to: Short Wave Station, Caixa Postal 709, Rio de Janeiro, Brazil, S.A.

YV5RMO

YV5RMO at Maracaibo, Venezuela, S.A., is now operating on 5850 kc. We have an unconfirmed report that YV4RC at Caracas is now on about 6350 kc.

VE9CS

A letter from the operators of this station states that they now operate on 6070

kc. as follows. Sunday, 1:45-9 p.m., 10:30 p.m.-1 a.m. Daily 6-7:30 p.m. Tuesdays 6-7:30 and 11:30 p.m.-1:30 a.m. The power of the station is only 2 watts at present, but will soon be restored to the normal 10 watts. The station is operated by Radio Service Engineers, Ltd., 734 Davie St., Vancouver, B.C., Canada.

Moscow

RW59 at Moscow on 6000 kc. now operates daily from 3-6 p.m. and in addition on Saturday from 10-11 p.m., and on Sundays from 5:15-8 a.m., 10-11 a.m. An English program is radiated on Monday, Wednesday, and Friday from 4:05-5 p.m., on Saturday from 10-11 p.m. and on Sunday from 6-7, 10-11 a.m., and 4:05-5 p.m.

S-W's Link Rotarians

(Continued from page 583)

livered his talk to the assemblage. His message went from the car by ultra-short waves to a receiver, the output of which was fed into the transmitter of W2XAF, and was thus rebroadcast to the meeting. Consequently, all receivers tuned to W2XAF at that time were also able to hear the "police-car" broadcast. In fact, Mr. Head's "speech in transit" was, it has since been learned, clearly received in Buenos Aires.

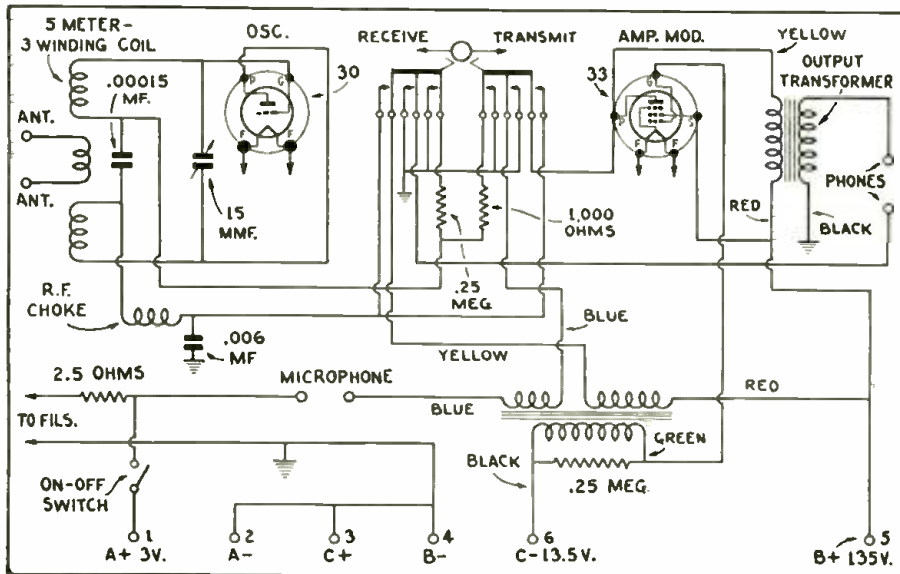

Hook-up of Transceiver

Please mention SHORT WAVE CRAFT when writing advertisers

Shhh! Shhh!
QUIET
Please!

Individually TESTED for NOISE

You Can't Hear Noise Because It Isn't There!

HERE IS THE SECRET



of
ELECTRAD'S
New **QUIET**
VOLUME CONTROL

THE resistance element is baked on the flat outer rim of a rigid Bakelite ring. Over this, the special-alloy floating contact gently glides in a straight path.

Result: The smoothest, quietest, longest-lived volume control ever devised. Absolute quiet is further guaranteed by individual testing of each control at the factory.

The molded Bakelite case, with removable metal end-cover, projects back-panel only 1/2 inch, when mounted. New-type power-switch (approved by underwriters) attached by a single screw. Extra-long, easily-cut aluminum shaft. Made in all standard sizes.

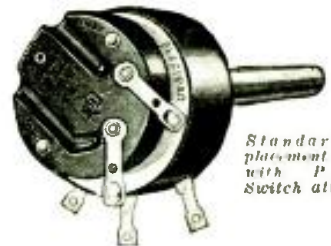

Standard Replacement Unit with Power-Switch attached

from
RESISTOR
Headquarters

ELECTRAD 1935 CATALOG

Electrad, Inc.
175 Varick St., New York, N. Y.

Please send new 1935 Resistor Catalog. Check here for folder on new QUIET Volume Control.

Name _____
Address _____

MAIL COUPON FOR

HOW TO BUILD, TEST AND REPAIR RADIO SETS



Radio Construction Library

Including Television, Short-Wave Receivers and Auto Radios. 3 Volumes. 6x9—1177 pages. 561 illustrations.

This practical Library includes: **PRACTICAL RADIO**—The fundamental principles of radio, presented in an understandable manner. Illustrated with working diagrams. **PRACTICAL RADIO CONSTRUCTION AND REPAIR**—Methods of locating trouble and receding faults and making workmanlike repairs. Discusses modern Short-Wave Receivers and installations of automobile radios fully. **RADIO RECEIVING TUBES**—Principles underlying the operation of all vacuum tubes and their use in reception, remote control and precision measurements.

Helps you to understand modern type receiving sets—full of construction data and practical kinks for the experimenter.

10 Days' Free Examination
Easy Terms

Free Examination Coupon

McGraw-Hill Book Company, Inc.
330 West 42nd Street, New York

Send me the new **RADIO CONSTRUCTION LIBRARY**, three volumes, for 10 days' free examination. If satisfactory I will send \$1.50 in ten days, and \$2.00 a month until \$7.50 has been paid. If not wanted I will return the books postpaid.

Name
Home Address
City and State
Position
Name of Company.....SWC-2-35

WORLD FAMOUS INTERNATIONAL DX
3 TUBE SHORT WAVE RECEIVER
ALL ELECTRIC ALL WAVE

6.75

Complete Kit containing all parts for the set and power supply, including speaker, 4 coils to cover bands from 11 to 220 meters and detailed diagram—
Custom built, extra \$1.75 Broadcast coil 75
3 matched tubes 2.25 Metal Cabinet 1.95

INTERNATIONAL BABY-RADIO
One Tube All Electric ALL WAVE

Kit contains all parts for the set and power supply with cabinet, 3 coils to cover bands from 40 to 500 meters and picture diagram—
Custom built, extra \$1.25
Double Purposetube 1.00
Headphone 1.50
FREE: Circular 130, up to 5 tubes

4.95

EXPERIMENTAL RADIO LABS.
168 WASHINGTON STREET NEW YORK N. Y.

RADIO COURSES

Radio Servicing
Including short wave receivers.

Radio Operating
Prepare for Gov't. license exam.

Radio Amateur Code

Resident Courses
Write for Booklet

New York YMCA Schools
6 West 64th Street New York City

New Battery Charger

● WHILE thousands of the older model homchargers are still in use, and giving satisfactory service after nearly fifteen years' operation, the use of larger and higher compression engines, dual electric horns, more powerful lights, auto radios, etc., has imposed such a drain upon the car battery that a much faster charging rate is necessary than heretofore.

The new Hi-Rate Homcharger is designed to meet these changed conditions, and starts charging at approximately ten amperes, this rate automatically dropping as the bat-



Newest High-Rate Battery Charger (No. 261)

tery becomes charged. Thus, even though the Homcharger may be left connected to the battery indefinitely it cannot harm it, since its output is automatically adjusted to the battery's needs.

While the idea of plugging into a neat receptacle installed on the car's dashboard, thereby getting away from lifting floor boards and soiling the hands in order to recharge a car battery, was originated by the Automatic Electrical Devices Company in 1920, the new Hi-Rate model employs a clamp-on receptacle, which requires no tools, and needs but a single connection to the ammeter terminal in rear of the dash.

Famous Radio School 20 Years Old

● Over 4,000 graduates of a well-known radio school located in Washington, D.C., who have specialized in radio, public address system and short-wave courses, attest to the thoroughness of the studies given by this school. The National Radio Institute has trained hundreds of men for all branches of the Radio Industry. Many of these men today are holding important key positions in the realm of Radio.

Like all large institutions, this school grew like the proverbial story of the "Acorn and the Oak Tree." Twenty years ago, in 1914, this school first came into existence as a resident school with four students, under the expert guidance of J. E. Smith, who has been its president all during its phenomenal growth.

Another expert who joined Mr. Smith in shaping the policies of the school was Mr. E. R. Haas, its Vice-President, and under the expert supervision of these men and a large teaching staff, the curriculum of the school has been gradually converted from a resident to a "home study" school.

This school is the only "home-study" institution in existence which has its own active alumni association. The course of instruction was prepared by some of the most foremost radio experts in America. Some of the "home study" courses given by this school today include instruction on practically every branch of radio, television and short-waves, including electronics. One of the important and distinct features of the N.R.I. course lies in the use of a radio construction kit, furnished students.

FREE

1934 Official Short Wave Radio Manual
1934 Official Radio Service Manual

Our Policy!

Our sales policy is first to quality merchandise to you at a low price. We guarantee a square deal. A 100% REFUND. If you are not satisfied, we will refund your money. We are actively engaged in a test of our policy.

FREE WITH ARCO TUBE PURCHASES, you may select a 1931 OFFICIAL SHORT WAVE RADIO MANUAL which sells for \$2.50, with your order, amounting to \$12. If you prefer, you can get FREE the 1934 OFFICIAL RADIO SERVICE MANUAL which sells for \$3.50 with orders amounting to \$15.00 or both manuals for orders of \$25.00.

THIS OFFER IS SUBJECT TO WITHDRAWAL WITHOUT NOTICE

Complete Stock Ready for Immediate Shipment

Order from this page—Remit 20% with order, balance C. O. D. All prices are F. O. B. FACTORY, Newark. Shipments go forward express or parcel post. No order for less than \$5.00 accepted.

Type No.	Fil. Voltage	Your Cost	Type No.	Fil. Voltage	Your Cost
1V	6.3	.50	75	6.3	.50
00A	5.0	.40	76	6.3	.45
01A	5.0	.30	77	6.3	.50
10	7.5	1.10	78	6.3	.50
12A	5.0	.40	79	6.3	.60
19	2.0	.60	80	5.0	.35
20	3.3	.40	81	7.5	1.10
22	3.3	.60	82	2.5	.45
24A	2.5	.45	83	5.0	.50
26	1.5	.30	84	6.3	.50
27	2.5	.30	85	6.3	.50
30	2.0	.45	89	6.3	.50
31	2.0	.45	X199	3.3	.45
32	2.0	.60	V199	3.3	.45
33	2.0	.60	1A6	2.0	.85
34	2.0	.60	1C6	2.0	.85
35/51	2.5	.50	2A3	2.5	.85
36	6.3	.50	2A5	2.5	.60
37	6.3	.40	2A6	2.5	.60
38	6.3	.50	2A7	2.5	.60
39/44	6.3	.50	2B6	2.5	1.10
40	5.0	.40	2B7	2.5	.60
41	6.3	.50	5Z3	5.0	.50
42	6.3	.50	6A4/LA	6.3	.60
43	25.0	.50	6A7	6.3	.60
45	2.5	.35	6B7	6.3	.60
46	2.5	.50	6C6	6.3	.60
47	2.5	.50	6D6	6.3	.60
48	30.0	1.10	6F7	6.3	.60
49	2.0	.50	12A5	6.3	.85
50	7.5	1.10	12Z5	6.3	.85
53	2.5	.60	25Z5	25.0	.60
55	2.5	.50	12Z3	12.6	.50
56	2.5	.35	PZH	2.5	.85
57	2.5	.50	WD11	1.1	.85
58	2.5	.50	WD12	1.1	.85
59	2.5	.60	21B6	7.5	.85
71A	5.0	.30	213	5.0	.60

Type	Fil. Voltage	Your Cost	Type	Fil. Voltage	Your Cost
182B	5.0	.60	485	3.0	.85
183	5.0	.85	586	7.5	1.75
484	3.0	.60	686	3.0	.85
401	3.0	1.50	403	3.0	2.00
2A7S	2.5	1.10	6Z5	6.3	.85
2B7S	2.5	1.10	24S	2.5	.60
2S/4S	2.5	1.10	25/25S	0.2	1.10
2Z2/G84	2.5	.85	27S	2.5	.50
6A7S	6.3	1.10	35S/51S	2.5	.75
6B7S	6.3	1.10	55S	2.5	.85
6C7	6.3	.85	56S	2.5	.60
6D7	6.3	.85	57S	2.5	.85
6E7	6.3	.85	58S	2.5	.85
6F7S	6.3	.85	75S	6.3	.85
6Y5	6.3	.85	85S	6.3	.85
6Z4	6.3	1.10			

● SPARTON TYPE TUBES ●

● MAJESTIC TYPE TUBES ●

● RECTIFIER AND CHARGER BULBS ●

125 Mill. rectifier tube B.H. (Raytheon type)	\$1.25
6-10 Amp. triode Rectifier Bulb (Tungar type)	2.00
2 Amp. charger Bulb (Tungar type)	2.00
5 and 6 Amp. charger Bulb (Tungar type)	2.00
15 Amp. charger Bulb (Tungar type)	7.50
UX-240M—5.0 Full Wave Mercury Vapor Rectifier	1.10
UX-281M—7.5 Half Wave Mercury Vapor Rectifier	1.90
UX-866—2.5 Half Wave Mercury Vapor Rectifier	1.10
UX-871—2.5 Half Wave Mercury Vapor Rectifier	1.10
UX-872—7500 Volts Half Wave Merc. Vapor Rectifier	1.00

TELEVISION TUBES AND PHOTO ELECTRIC CELLS

Photo Cell (Potassium), 2 1/2" Length Overall	\$1.75
Photo Cell (Potassium), 3 1/2" Length Overall	2.10
Photo Cell (Caesium Type), 4 1/2" Length Overall	7.90
Photo Cell (Caesium Type), 5 1/2" Length Overall	5.90
Photo Cell (Caesium Type), Same as UX 866	4.90
Television Tube (Neon Reflector), 1 1/2" Sq. Cathode	2.85
Television Tube (Neon), 1 1/2" Sq. Cathode	2.85
Television Tube (Neon), 1 1/2" Sq. Cathode	3.85

Specifications and quotations on TRANSMITTER TUBES, CRATER TUBES, GLOW LAMPS, HIGH VACUUM TYPE CATHODE RAY TUBES, suitable for television and standard cinematographic uses. SUBMITTED ON REQUEST.

ARCO TUBE COMPANY
232 Central Avenue Newark, N. J.

5-Meter Xmitter Uses "Dynamotor"

(Continued from page 599)

provide enough power to modulate the 6A6, that is, with the microphone being used to drive the 42 and not a stage of speech amplification. Speech amplifiers complicate matters and it was decided to follow a course of cut and try in order to obtain the most efficiency. The "good book" says that the bias for the 42 with 250 volts on the plate should be 16.5 volts; this to be obtained with a 500-ohm resistor connected in series with the cathode. Under these conditions there was not enough modulation, with the oscillator running with 3 watts input, to make the voice "understandable." However, as the bias was increased on the 42, the output increased considerably. Best results were obtained with 3,500 ohms in the cathode lead. This brings about a condition where the 42 is operating nearly class "A" prime. Not a good condition in a single-ended audio amplifier, but the distortion at voice frequencies is not very bad—the proof is that the quality was reported "very good." The modulator is explained first, because it is much more "tricky" than the oscillator. With an audio circuit of this type, every possible amount of gain is needed and for this reason the reader is advised to try reversing the secondary connections of the microphone transformer, and also the connections to the "mike" battery itself, until best results are shown by an increase in the percentage of modulation.

How Tuning Condenser Is Made

If the following instructions are followed there will not be the slightest difficulty with the oscillator part of the transmitter. The tuning condenser was made from a National type ST90. The stator

grees of coupling to obtain best results.

Referring to the diagram we see that the whole transmitter is simplicity itself. Plate modulation is used and the B plus is fed to the plates of the oscillator and modulator through a small iron core choke having about 15 henrys inductance and capable of carrying at least 50 milliamperes, which is the total amount of current drawn by both tubes. The condenser connected across the cathode resistor of the modulator tube *must* have a capacity of 20 mf. with a working voltage of 35 volts. The primary of the microphone transformer is connected so that the microphone button current is supplied by the storage battery, and it is only necessary to insert the plug in the jack provided on the front of the box. A single-pole single throw toggle switch allows the B plus to be broken in order to throw the transmitter "on" and "off."

The case in which the transmitter is built is identical to that used for the receiver previously mentioned and measures 6½" high, 5" wide and 8¾" deep. There is a subpanel measuring 5¾" by 7" and on it is all the equipment for the modulator and oscillator. The antenna connections are brought out at the left side of the box.

19 Miles Covered

Several types of antennas can be used with this transmitter and several are shown in the diagram. There is only one tuning control and that is the dial on the front of the box, and there is nothing to get out of adjustment. We have had the pleasure of working 19 miles with an R5 report—not bad, eh?

Parts List for 5-Meter Portable Transmitter

- 1—SE-90 National condenser, remodeled; see text.
- 1—20 mf., 35-volt electrolytic condenser, Aerovox.
- 2—8mf. 300-volt electrolytic condensers, Aerovox.
- 1—5000-ohm wire wound, 5-watt resistor, Aerovox.
- 1—3500-ohm, 2-watt resistor, Aerovox.
- 1—single-button microphone transformer, Universal.
- 2—15 henry, 60 ma., iron core chokes.
- 1—7-prong (large) Isolantite socket, National.
- 1—6-prong wafer socket, Na-Ald.
- 1—single open circuit jack, I.C.A.
- 1—Sp-St toggle switch, I.C.A.
- 1—250-volt, 50 to 60 ma., 6-volt dynamotor.
- 1—aluminum panel, 1/16"x5¾"x7". Blank.
- 1—carrying case, see text. Wholesale Radio.
- 1—6A6 tube, Sylvania.
- 1—42 tube, Sylvania.
- 1—National, 3-inch dial.
- 1—twin antenna terminal strip, Na-Ald.
- 1 set of coils, see text for winding details.
- 1—high-gain, single-button hand microphone, Universal.

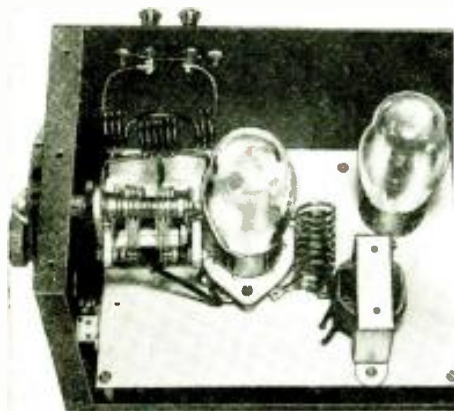

Inside view of oscillator and modulator combination. Notice the extreme simplicity.

and rotor were remodeled to provide a split stator condenser having three rotor and two stator plates in each section. There are 6 turns in the plate coil and 8 turns in the grid coil. They are wound on a ¾ inch form and the spacing between turns is about equal to the diameter of the wire, which is number 12 solid enameled. Tinned buss-bar will do as well, of course. Each coil is center-tapped for the grid return and the B plus to the plates. The 6A6 operates as a 2-tube push-pull oscillator and gives remarkable efficiency at very low inputs. The size of the grid-leak was determined experimentally. We started with a 20,000-ohm unit and decreased it—the input to the oscillator increases as the leak resistance decreases—until we could just obtain full modulation. This gave a plate current of 20 milliamperes with a leak of 5,000 ohms, without the antenna the plate current was in the order of 14 or 15 "mills." (M. A.) The antenna coils have three turns each and are identical to the other coils in size of wire and diameter. We found that very close coupling was needed, but the reader is advised to experiment with various de-

New S-W Tuning System

(Continued from page 593)

As the plates of the variable condenser are gradually brought in, more and more current passes through coil L2 and neutralizes the magnetic field of coil L1 to a still greater extent until when the plates are completely meshed, the aerial current is divided into two equal parts, one half passing through each coil at which time the inductance is at a minimum. There is no such thing as dead-end effect in either of the coils, as found in practically every other system of "inductance" tuning, for at all times the coils are in the circuits, even when the plates of the condenser are all the way out.

Please mention SHORT WAVE CRAFT when writing advertisers

The All-Electric All-Wave Receiver

Greatest Value On The Market

6F7
76
12Z3
tubes

New 4 in 3 circuit

A completely electrified all-wave receiver capable of world-wide



reception. Circuit has been re-designed so as to be bigger and more powerful than ever. Uses 6F7 (2 tubes in 1 bulb), 76 & 12Z3 tubes as screen-grid regenerative detector, 2 stage audio amplifier, rectifier & built-in power supply. Due to the use of the dual purpose tube, the 6F7, this circuit produces 4 tube performance from 3 tubes. No batteries. Simply plug into 110 volts house lighting circuit & operate. Sensitive & gives great volume. Works speaker on many stations. Covers 10-600 meters. Mounted on heavy black crackle finish metal chassis and panel. Coils for 10-200 meters. Instructions included. FOREIGN RECEPTION GUARANTEED.

KIT ASSEMBLED and ready to wire

\$5.95
Wired & tested extra \$1.25
Matched Arcturus tubes 2.25
Broadcast coils (2) 0.95
Beautiful black finish metal cabinet hinged lid 1.00

THE DC ALL-WAVE RECEIVER

19
33
tubes

New 3 in 2 circuit

An extremely powerful battery operated set. Designed for loudspeaker operation. Tremendous headphone volume. 1 bulb & 33 tubes in



special 3 tube circuit. Special filament arrangement produces low filament current drain. Requires 3 dry cells, 2.45 volt batts., & 1 C battery. Range 10-600 meters. Mounted on beautiful black crackle finish metal chassis & panel. Owners report foreign stations on speaker. Coils for 10-200 meters. Instructions included. FOREIGN RECEPTION GUARANTEED.

KIT ASSEMBLED and ready to wire

\$5.75
Wired & tested \$1.25
Matched Arcturus tubes 1.90
Broadcast coils (2) 0.95
Beautiful black finish metal cabinet hinged lid 1.00

The EILEN Masterpiece "A"

Designed for those who demand the ultimate in results & appearance. Uses 6F7 (2 tubes in 1 bulb), 43, & 12Z3 tubes in special 1 tube circuit, as screen-grid RF



amplifier, detector, power pentode audio amplifier, rectifier & built-in power supply. Operates from 110 volt house lighting circuit. Humfree. Delivers enormous headphone volume. Loudspeaker may be used. This receiver will amaze you by its ability to consistently pick up weak foreign stations with good volume. Illuminated airplane type vernier dial. Range 10-200 meters. 4 plug-in-coils & instructions included. FOREIGN RECEPTION GUARANTEED.

Receiver, ready to wire \$9.95

Cabinet, extra 1.00
Wired & tested, extra 2.00
Arcturus tubes 2.75
Broadcast coil .95

SPECIAL: Loudspeaker mounted in beautiful oak finish cabinet for use on any of the above receivers \$3.95
Cannonball phones 1.35

THE EILEN 2

An inexpensive & simple receiver that is ideal for the beginner & constructed of the best grade parts & uses one of the new type 19 (2 tubes in 1 bulb) in a 2 tube circuit. Features real headphone volume. Operates from 2 dry cells & 1.45 volt battery. Built into beautiful black crackle finish metal cabinet. Compact & makes an ideal portable.



Kit \$3.95

Wired & tested extra \$1.00
Arcturus 19 tube .95
Broadcast coils .95

able. Coils for 10-200 meters, & instructions included. FOREIGN RECEPTION GUARANTEED.
C.O.D. ORDERS FILLED. PROMPT SHIPMENT.
EILEN RADIO LABORATORIES
Dept. SC2, 463 Fourth Avenue, New York, N. Y.

The DX2 ALL-WAVE RECEIVER

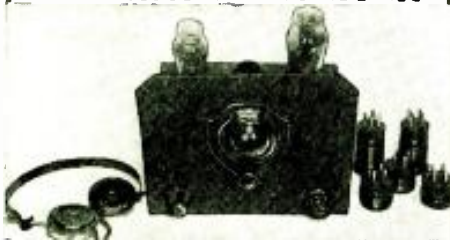

Heat foreign short wave broadcast, police calls, amateur telephonic stations, transatlantic and experimental stations, radio telegraph as well as regular broadcast stations in the U. S. with this receiver. Uses type 30 and 33 tubes as regenerative detector and pentode amplifier. Great volume. Beautiful black crackle finish metal chassis and panel. Uses 2 dry cells and 1-45V. battery, and 1C battery. Coils for 10-200 meters, and instructions included. Foreign Reception is Guaranteed.

Kit \$4.35

Wired and tested, extra \$1.25
 Arcature tube, 1.50
 Broadband coil, .95
Special offer: Complete receiver, ready to use, less phones and batteries, \$7.75

THE SIMPLEX RECEIVER

An extremely simple electrical receiver for the radio beginner. Requires no batteries. Operates entirely from the 110 volt house lighting current. Works on short aerial. No ground connection needed. Uses one 12A7 (2 tubes in 1 bulb) as regenerative receiver and complete power supply. Built in neat, black enamel finished metal cabinet. Vernier dial and smooth regeneration control. Unusually good value for the money. 2 coils covering 90-340 meters and instructions included. 3 extra coils extending range down to 10 meters, extra \$0.60.



Kit \$3.95

Wired and tested, extra \$1.00
 Arcature tube, .95
Special offer: Complete receiver, ready to use, less phones, at only \$5.65 (2 coils)

Headphones, 2000 ohm, \$1.35
 C.O.D. orders filled promptly

CENTRALLION ENGINEERING CO.
 Dept. Sw.2, 461 Fourth Ave.
 New York, N.Y.

COMPLETE LINE OF AMATEUR TRANSMITTERS, BOTH CRYSTAL CONTROLLED AND SELF EXCITED. MONITORS, BAND SPREADS, RECEIVERS, POWER SUPPLIES, AND ACCESSORIES AVAILABLE. STAMP FOR CATALOGUE

How To Obtain High Fidelity Results

(Continued from page 612)

now much talk. It seems to us that some who use this expression do not know what it means exactly. This is surprising, because it is really quite simple to understand what it involves. For example, if we receive from a radio station a tone signal of 1000 cycles only, and we use a receiver with a high distortion factor, our loudspeaker will radiate the tone of 1,000 cycles and furthermore as distortion component a tone of 2,000 cycles. (see fig. 2.)

If our amplifier with a total output of 1 watt reproduces the tone signal of 1,000 cycles in the loud-speaker, for instance with an output of 0.9 watt, and the harmonic component of 2,000 cycles with 0.1 watt, then we have a distortion factor of 10 percent in our reproduction. It is quite interesting to know, that our loud-speaker reproduces not the tone of 1,000 cycles and the tone of 2,000 cycles as separate tones, but both together as an audio frequency mixture, which sounds very unpleasant to our ears. When we realize that our receiving sets very often have a distortion factor of 20 percent then we will no longer grumble at the radio stations for transmitting such "harsh" sounding music.

There would be much more grumbling than there is, if our ears had not been so badly educated in the last 10 years by our poor sound-quality radio receivers. That is the reason why we very often do not know how poorly our speaker reproduces the wonderful programs transmitted over the country at a great expense. If the situation is this bad in the case of broadcasting reception from the big stations, the situation is even worse in the case of amateur short-wave broadcasting. These small stations do not always have high class equipment, and so the distortion factor here is frequently astonishing. When a receiver with a high distortion factor reproduces such a program—awful!

How can we eliminate all this distortion? That is simpler than it seems. Generally we have two main sources of distortion: First—the detector stage, and then—the audio stage. In this connection we shall need to say something later on about the loud-speaker, but now let us direct our attention to the two main points.

Starting with the audio stage, if we throw out our good old friend the square-law detector, with its auxiliaries the grid condenser and the grid-leak, and use a diode for detection, and an extra triode for regeneration, we can eliminate 50 percent of all distortion. We do not need profound scientific knowledge to understand that an oscillating tube has a very complicated characteristic, and that the use of a regenerative detector always causes distortion.

The distorting influence of the "feedback" effect upon true tone reproduction is easy to recognize when regeneration is carried too far. At first the music is harsh, and later on we get a whistle only. This experiment might be a little bit elementary, but it shows us, without any doubt, how important it is to avoid the feedback effect if we desire true music reproduction. It shows us further, that we have to divide the functions of the old-fashioned regenerative detector by using two tubes*, or at least two-tube systems in a single bulb, if we want to use a certain amount of feedback effect without producing objectionable distortion.

The best would be to throw out the regenerative detector entirely, but that leads us to the "superhet" circuit, and many of our short-wave friends do not feel very enthusiastic about this idea.

We must expect a complete turnover in the technique of receiver construction. The growing interest in the new iron core tuning method is a sign pointing to this end. In the wave range from 500 to 1500 kc. there will be used iron tuned circuits, and above this range very small tuning condensers ganged with the dial of the iron tuning coils.

*See "Regena Type" Receiver, next issue.
 †See article "3 Tubes" page 162, Dec. 1934 issue.

WESTINGHOUSE



Power Generator

MANUFACTURED FOR U. S. SIGN. CORPS

SPECIFICATIONS

WEIGHT—14½ lbs.
 HOUSING—Aluminum (Diameter—6¼ in. Length—5¼ in.)
 SHAFT—2 3/16 in. (driving end) (diameter 9/16 in.—the end is threaded for a distance of ¼ in.)
 BASE—Cast Iron. (Length—7¾ in. Height—1 9/16 in. Width—4¾ in.)
 OUTPUT—200 Watt 110 volts AC (speed 4500 R.P.M.)
 STATORS—Two pairs (two North and two South)
 ROTOR—12 tooth inductor. Built in commutator. Rotor turns in ballbearings.
 (GENERATORS HAVE NEVER BEEN USED)

FREE With each Westinghouse Generator we supply free of charge a set of diagram-blue prints and instructions showing twenty-five different uses, giving technical information, electrical Hookups and installing explanations. We also include free of charge a set of four replacement carbon brushes.

THERE ARE OVER 25 APPLICATIONS SOME OF WHICH ARE:

- A.C. DYNAMO lighting from eight to ten 20 Watt 110 Volts lamps
 - SHORT WAVE TRANSMITTER supplying 110 Volts AC for operating "Ham" transmitter.
 - OPERATING 110 V. AC 60 CYCLE RADIO RECEIVER in DC districts.
 - MOTOR GENERATOR.
 - PUBLIC ADDRESS SYSTEMS.
 - ELECTRIC SIRENS on motor boats, yachts, etc.
 - CAMP LIGHTING.
 - SHORT WAVE artificial "fever" apparatus.
 - TELEVISION.
 - PELTON WATERWHEEL for lighting or other purposes.
 - AIRPLANE: for lighting strong search lights or electric signs.
 - LABORATORY WORK.
- Furthermore the following uses are explained: How to obtain electrical power:
- from a Windmill, from available Waterpower, from your Automobile, from your Motorcycle, from your Bicycle, Footpeds or Handcrank (for transportable Radio Transmitters, Strong Floodlights, Advertising Signs); how to operate AC Radio sets from 32 V.DC farm light systems; how to operate two generators in series to get 200 V.AC; how to obtain two phase and three phase AC., etc., etc.

Generator as described above including four replacement carbon brushes and folder containing instructions and uses **\$7.90**

Shipping weight 13 lbs. (Replacement carbon brushes bought separately \$1.50 per set of four. Set of instructions bought separately \$1.00.)

Remit by check or money order. Shipped Express Collect if sufficient money is not enclosed for parcel post. Money refunded if not satisfied.

WELLWORTH TRADING COMPANY
 560 W. Washington Blvd. CHICAGO, ILL.

WELLWORTH TRADING COMPANY SW-2-35
 560 W. Washington Blvd., Chicago, Ill.

Enclosed you will find my remittance of \$..... for which please send me

() Power Generator, \$7.90 each.

Name

Address

City

RADIO

ENGINEER OR JUST HANDYMAN?

Why study courses costing three times as much and hit only the "high spots" of what you want?

Here's a Radio and Television home-study course that will give you sound engineering principles. Not just elementary instruction but advanced training that's vital—yet a beginner can master it!

Ask about our fair price. Less than

\$1.25 A WEEK

for a few, short weeks! Write

RADIO TECHNOLOGICAL COLLEGE
 1202 Omar Avenue Houston, Texas



HAVE YOU A HEADACHE

trying to find out where you can obtain certain parts that you need for your short wave radio or your station? Stop worrying.

This is the "House of a Million Parts", where you can obtain the most up-to-date or any obsolete part.

Send us a list of your needs and we will quote our lowest prices.

Interesting literature mailed free.

LEOTONE RADIO CO.

63 DEY STREET Dept. S-2-35 NEW YORK CITY

Please mention SHORT WAVE CRAFT when writing advertisers

The use of iron core tuned circuits makes it possible to get a pretty uniform sensitivity response over the full range from 500 to 1500 kc. This is something hard to obtain if we use condenser tuning in circuits with the same range. By this method we get not only a better receiver characteristic, but avoid disturbances caused by balancing of large size tuning condensers, often used together for the long and the short-wave ranges. We also profit by the using in the short-wave range of tuning condensers of an exact fitting size, so improving the characteristic of the short-wave circuits.

But before this construction can be touched it is necessary to find a detector stage with all the advantages of the regenerative detector—without its disadvantages. The problem here involved requires the use of a diode operating under linear conditions, and at the same time to employ the feed-back effect without causing distortion. But that is not all. The solution is not so simple, because we must pay attention to the fact that the diode does not really work in a linear manner if we don't provide it with sufficient r.f. energy.

If we have a signal from a powerful station it should not be difficult to provide the diode with sufficient energy. But if not, we need a powerful r.f. amplifier to obtain a linear operation of the diode. Therefore we must see that the energy consumption of the projected extra feed-back circuit should not be too great. It is very simple to compensate the energy consumption of the special regenerative tube by using a strong feed-back effect. But the less we use the feed-back effect the better will be our distortion characteristic. The simplest and best method to follow is—in case of inductive coupling of both circuits, by using a *weak coupling*, or we can use a capacitive coupling by a "condenser" potentiometer. (see Fig. 3.)

Each one of the circuits shown in Figs. 4 and 5 has certain disadvantages as well as advantages. If we use a duplex diode—triode (see Fig. 5) we choose the simpler and cheaper way, but we cannot be 100 percent sure that we will get a circuit without any influence from the regenerative triode circuit to the duplex triode circuit.

The use of a single diode tube is, in this respect, much better, but the efficiency of a half-wave detector is not as good as that of a full-wave detector. The last word about this kind of detection in connection with "neutralized" regeneration has not been said. Both circuits are only suggestions. Here again is a fine opportunity for the amateur to make some interesting and valuable experiments at slight cost. There are possibly many other methods and it will pay to study them.

Now to the improvements of the audio stage: First we have to keep in mind that pentodes in an audio amplifier are *out of the question* because they introduce distortion, but if we use pentodes as triodes there will be no harm, and sometimes we can obtain a slight improvement in this way. (see Fig. 6.)

It is not necessary to say that if we want to construct a *high-fidelity* audio amplifier we need audio transformers with a very straight response curve, as shown in Fig. 7, but these transformers are not cheap. We should also realize that *low-frequency* response increases with primary inductance. There are now many audio transformers built into radio receivers which sometimes have a sufficiently *high-frequency* response, but are not so effective in the lower range down to 50 cycles. If we have such transformers we can boost the low frequency response by using an old trick—that is, tuning the primary with a by-pass condenser.

This is, of course, only an emergency trick, but it saves money and is quite satisfactory. In case we use interstage transformers the circuits may be bridged by a condenser C1 as shown in Fig. 8. How big this condenser shall be depends on the degree of shortening required, and the amount of leakage. A condenser from 0.1 mf. to 1 mf. might be the right one and fit in. To boost the transformer at low frequencies we connect the condenser C2 in the circuit according to Fig. 8. Ad-

vice as to what size this condenser should be is hard to give, because it depends on the primary inductivity of the transformer used, and can only be determined by individual experiment.

It might be in some cases that a condenser of 0.25 mf. will be found sufficient. In other cases we may need 3 to 5 mf. To change the response in the high frequency range of an old-fashioned transformer seems hardly advisable. An audio transformer with a "cut-off" of around 5,000 or 6,000 cycles cannot be used. There are now audio transformers upon the market with a straight characteristic from 50 to 15,000 cycles and higher; see Fig. 7, and we should buy only such transformers if we can afford it, and if we are particularly anxious to obtain really *high-fidelity* amplification.

The simplest way that we can obtain *high-fidelity* amplification is by use of push-pull stages. Push-pull allows the cancellation of even order harmonics, and also of plate and filament supply hum. But until recently it had been common to use self biased tubes in push-pull stages. This is absolutely impossible if we are looking for a real high fidelity performance. Since the output of an amplifier of this type is not of uniform value but a continuous succession of valleys and peaks, the peaks very often drive the grids of the tubes positive. We know that when this occurs there is a tendency both for grid current and plate current variation, and these effects in turn tend to introduce strong distortion.

In a self-biased amplifier the plate current flows through the bias resistor, and any variation of plate current causes a corresponding change in the bias voltage of the tubes. Since fixed bias eliminates this effect entirely, higher power output is obtained from a given pair of tubes.

The secondary windings of the transformer should not have a high resistance. If the resistance is high the flow of the grid current in the windings will cause a big voltage drop with resulting distortion. For that reason we should be careful in buying transformers to see that secondary windings have the requisite low resistance.

It is very often difficult, in case of push-pull amplification to match the tubes in such a manner as to obtain full "hum cancellation." An effective way to obtain good hum cancellation is to use a two-arm potentiometer as a bias resistor. These resistor arms allow an individual adjustment of the bias voltage so that by the use of a plate current milliammeter the tubes can be accurately balanced. The difficulty of matching the tubes, of a class B output stage to a speaker load, is a matter of common knowledge, due to the fact that a speaker system which is 500 ohms at 1000 cycles may likewise have an impedance of 5000 ohms at 10,000 cycles, thus lacking constancy of impedance. A simple trick to compensate for this inconstancy of impedance is that of using condensers and resistors as shown in Fig. 9. For 46 or 59 tubes R1 and R2=3000 ohms, C1 and C2=0.08 mf. For 19, 53 or 79 tubes R1 and R2=5000 ohms, C1 and C2=0.05 mf. For 49, 89 or 203A tubes R1 and R2=6000 ohms, and C1 and C2=0.04 mf.

(Practical Hints on Attaining "High Fidelity" in the Acoustic Apparatus, Loud-Speakers, etc., will be given in the next article.)

CORRECTION NOTICE

In the Question Box of the January issue, John Smith of Norfolk, Virginia, asked where he could obtain an amateur license. The correct place is the Custom House of Norfolk, Virginia.

BUILD YOUR OWN

Short Wave Receiver or 5 Meter Transceiver

Not only will you get great satisfaction from building your own, but you'll *save money* too! The ICA Kits described below are scientifically engineered to render the best possible service and satisfaction. Be sure to ask your Dealer or Jobber about ICA kits or Parts before you build or buy!

ICA 5-METER TRANSCEIVER

A quality transceiver in 3 models: 2 volt, 6 volt on A.C. models. So easy to build! Made completely of ICA parts. Comes complete with instructions, diagrams, etc. List prices (respectively) \$19.50, \$19.25, \$19.75



ICA SHORT WAVE RECEIVERS

A whole line to choose from: 1 and 2 tube battery sets, and 3, 4 and 5 tube All Electric models. Here are the world's easiest kits to build. Each comes complete with point to point diagrams. Licensed U.S. Pat. and Hazeltine Patents. List prices \$9.95 and up. Write for facts before you build!

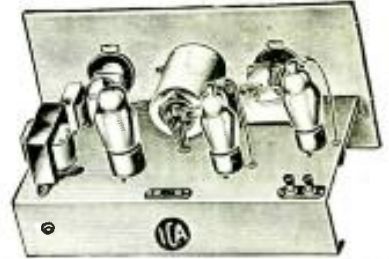

QUALITY PARTS

are known the world over for their reliability and dependability. Below are shown but a few of the hundreds of items which we manufacture and list in our great new catalog. The list prices on all items shown here are subject to a discount of 10% when purchased through your Jobber or favorite Mail Order House. Insist upon ICA parts and kits to insure satisfactory performance!

Flexible Coupler

Efficient and inexpensive. Of flexible fiber. Diam. 3/4" two 1/4" bushings mounted on flexible phosphor bronze spring. List price **35c**



Dial and Pointer Knobs

Direct drive. Heavy aluminum, black finish. Silver etched lines and numerals. 3 1/2" diam. Callibration 100 to 0 or 0 to 100. List price 75c. 2" diam. Callibration 100 to 0 or 0 to 10. List price 50c



New All Wave DOUBLE Doublet Antenna

New type noise reducing system for all-wave and short wave receiver. Big improvement over ordinary doublet antennas. 60 ft. span; List price, \$5.50. Special 34 ft. span where there are space limitations. List Price **\$6.00**



Standoff Insulator With Jack

Will take Banana or G.R. type plug. 1 1/2" high, base 1" x 1 1/2". Takes standard screws. Black or white. List Price **12c**



"Little Pete" Standoff Insulator

Very small. Made of Insulex. Handy where small space is available. Only 1" high. Base 1/2" x 3/4". Ready for mounting. Black or white. List price **6c**



Universal Midget Condensers

Removable shaft with lock nut provides permanent condenser alignment. Insulex insulation. Spacing .026". 15, 25, 50, 100 and 110 mmf. capacities. List prices:

85c, 95c, \$1.05, \$1.15, \$1.50



BIG NEW 1935 CATALOG

sent on receipt of 10c coin or stamps to cover cost of handling and mailing. Lists hundreds of parts, kits and accessories. Supply limited so send now to avoid disappointment.

INSULINE CORP. OF AMERICA
23-25 Park Place, Dept. W-25, New York, N. Y.

WHEN CHOOSING A RADIO SCHOOL

RCA Institutes, with its reputation firmly established by 25 years service, is an institution recognized as an important factor in the radio industry.

Whether elementary radio principles or advanced subjects, sound applications, mathematics or practical radio engineering, RCA Institutes is prepared to give you the instruction you need.

Resident Schools at New York and Chicago
Modern Apparatus and Laboratory Equipment—Conveniently Located—Day and Evening Classes—Tuition Rates \$3 to \$10 Weekly.

Extension courses for home study on convenient "no obligation" plan. Examination and technical advisory services. Free post-graduate practical training at resident school with modern equipment under instructing engineers.

Write for Catalog.

RCA INSTITUTES, Inc.

Dept. SW-35



75 Varick Street
NEW YORK

1154 Merchandise Mart
CHICAGO

Recognized Standard in Radio Instruction Since 1909.

THE AMATEURS FAVORITE DX 3

ALL - WAVE
ALL
ELECTRIC
AC - DC



Power supply built-in.

Complete Kit
\$6.50

Custom built, extra... \$1.85
Extra for Speaker 1.35
Extra for Cabinet 1.95
Arcatux Tubes 2.20
Broadcast Coil .75

- Built-in Speaker.
- Uses 6106, 70 and 38.
- Very easy to build because it uses only the best standard parts. The full size blue print explains all the connections so clearly that even if you have never built a short wave set before, you will have no difficulty in assembling it correctly.
- Foreign Reception Guaranteed.

WORLD TROTTER RADIO LABS.
168 Washington Street, Division C-4, New York, N. Y.

CHASSIS

We manufacture all the modern types used by the leading short wave set builders, experimenters and hams in all finishes. Send drawing for estimate. We make any size.

KORROL MFG. CO., Inc.
232 Greenwich St., Dept. S.W., New York

FACTORY PRICES Short Wave—All-Wave—Kits

FREE 1935 CATALOG A

RADIO CITY LABS.

Suite 1222-30 Rockefeller Plaza
New York, N. Y.

5 Meter Station Atop Hotel

(Continued from page 584)

The members of the Garden City Radio Club attribute most of their success to the height of the antenna itself, the efficiency of the transmission line which is run between the antenna and the "long lines" oscillator, as well as the effectiveness of the "long lines" oscillator itself.

The circuit diagram of the entire transmitter is illustrated in figure 1, and it is readily seen that it is a simple modification of standard circuits which have been in use by "hams" for several years.

Details of the oscillator circuit were originally given by George W. Shuart, W2 AMN, in the October issue of SHORT-WAVE CRAFT and this type of oscillator has proved entirely satisfactory; not only from the standpoint of its radiating qualities, but also from the standpoint of the particularly high quality of voice transmission which it makes possible.

Tuning Sharp Yet Simple

While, fundamentally, the entire outfit can be characterized as a "modulated oscillator," the received signal, even where a superheterodyne receiver is employed, is almost as good as a crystal control "rig" and is very much better than an improperly tuned crystal outfit. Another feature which has been found desirable in the operation of this transmitter is the simplicity with which it may be tuned, particularly when it is possible to secure a check on the tuning from an operator a considerable distance from the transmitter. National sockets, chokes and stand-off insulators are used.

Tuning of this nature has been carried on very frequently with Station W2AMN, at Ramsey, New Jersey (26 miles from New York City), which has enabled the club operators to get a very definite check on the performance of their station every time any change is made in any of the transmitting equipment or in the various antennas which have been employed.

Very definite proof has been established that, in order to secure the most satisfactory output, it is essential to have the oscillator tuned to the exact resonant frequency of the antenna itself.

The Transmitting Antenna

The antenna which has proved most satisfactory for general communication purposes is a half-wave vertical rod, 8 ft. 2 in. long, mounted on 10" stand-off insulators and raised 20 feet above the uppermost peak of the hotel.

Strange as it may seem, the antenna itself is nothing more than a piece of galvanized iron pipe 1 inch in diameter (O.D.). The transmission line is made of stranded enamel wire (heavy grade) spaced by Lynch U.S. Navy standard insulators. The line has an approximate impedance of 430 ohms and is approximately 125 feet long. Where the transmission line joins the vertical radiator, the spacing is increased to 25 inches and the distance from the vertical radiator to the first spacing bar is 30 inches. Ordinary galvanized iron ground clamps are utilized to make the connection from the transmission line to the vertical radiator.

For long distance communication in a definite direction, attempts have been made to utilize two element beam antennas with suitable radiators and reflectors. The radiators and reflectors, in this case, were made of aircraft duralumin in order to provide rigidity and light weight.

Even though great precautions were taken to line up the elements in this beam, it was found that considerable difficulty was experienced on almost every occasion, as a result of the "whipping" of the beam elements, caused by the high winds which prevail at this height. On the other hand, on evenings when the wind was not high, reports from receiving stations in Yonkers—approximately 30 miles away, indicated an increase of signal strength of from 100 to 200 percent.

HERE IT IS

SHORT WAVE SET BUILDERS MUST HAVE THIS BOOK

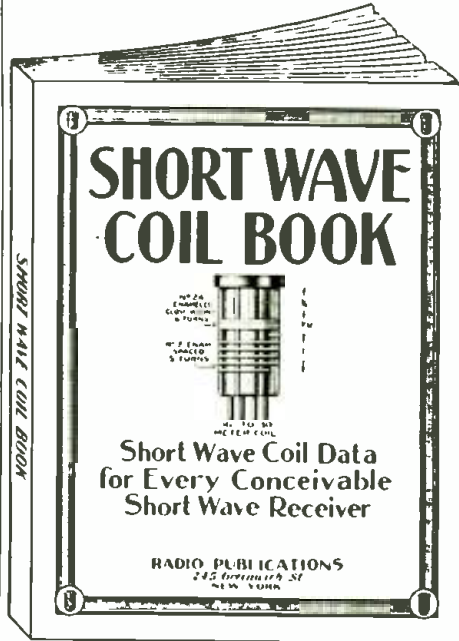

SHORT WAVE COIL BOOK

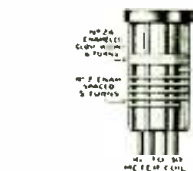

Short Wave Coil Data for Every Conceivable Short Wave Receiver

RADIO PUBLICATIONS
245 Broadway St
NEW YORK

FOR the first time, it is now possible for the experimenter and short wave enthusiast to obtain the most exhaustive data on short wave coil winding information that has ever appeared in print.

As every experimenter who has ever tried to build a short wave set knows only too well by experience, the difference between a good and a poor receiver is usually found in the short wave coils. Very often you have to hunt through copies of magazines, books, etc., to find the information you require. The present data has been gotten up to obviate all these difficulties.

Between the two covers of this book you now find every possible bit of information on coil winding that has appeared in print during the past two years. Only the most modern "dope" has been published here.

No duplication. Illustrations galore, giving not only full instructions how to wind coils, but dimensions, sizes of wire, curves, how to plot them, by means of which any coil for any particular short wave set can be figured in advance, as to number of turns, size of wire, spacing, etc.

There has never been such data published in such easy accessible form as this.

Take advantage of the special offer we are making today, as due to increasing costs, there is no question that the price will increase soon.

RADIO PUBLICATIONS
97 HUDSON STREET
NEW YORK, N. Y.



Radio Publications,
97 Hudson Street,
New York, N. Y.

2-35

Please send immediately, your Short Wave Coil Book, for which I enclose 25c herewith (coin, U. S. stamps or money order acceptable). Book is to be sent prepaid to me.

Name.....

Address.....

City and State.....

Please mention SHORT WAVE CRAFT when writing advertisers

Announcement by HUGO GERNSBACK

I ASK YOU A FAVOR

YOU HAVE BEEN AN ENTHUSIASTIC READER OF SHORT WAVE CRAFT. I ASK YOU A FAVOR. PLEASE TAKE CARE TO SEND ME YOUR MONEY'S WORTH. NOW, I ASK YOU A SPECIAL FAVOR TO ME. THAT IS, ON OR AFTER JANUARY 25TH YOU GET FROM YOUR MONEY'S WORTH A COPY OF THE OFFICIAL SHORT WAVE CRAFT MAGAZINE. TAKE IT HOME AND READ IT CAREFULLY.

IF AFTER YOU HAVE BOUGHT YOUR FIRST COPY AND HAVE STUDIED ITS CONTENTS, YOU WISH TO RETURN THE COPY TO ME, I AUTHORIZE YOU HEREWITH TO RETURN THE COPY TO THE ADDRESS TO ME AND I WILL RETURN YOUR LETTER TO YOU. BUT WHY YOU DO NOT LIKE THE MAGAZINE OR IF YOU DO NOT THINK IT IS WORTH THE MONEY I ASK FOR IT, YOU TO BE THE SOLE JUDGE.

THIS IS MY SPECIAL PROMISE TO YOU.

Hugo Gernsback

P. S.—If you cannot get the magazine at your newsstand due to sell-out, send 25c in cash, stamps, or money order, and we will send the magazine to you, different from the other magazines. OFFICIAL SHORT WAVE CRAFT MAGAZINE, 89 Hudson Street, New York.

Announcement by HUGO GERNSBACK

TELEVISION and "Airtone" short-wave stations. Special list of the best of star short-wave stations, with their frequencies and call letters. Valuable hints to the "short-wave listener"—how to locate the "weak" distance stations, etc. Different time zones, in various parts of the world together with a map showing the location of short-wave stations. "Best time to listen in" by M. Harvey Gernsback. How to identify short-wave stations by their "musical notes" signatures. Question and Answer department for the Short-Wave Listener. Notes on "foreign" as well as "domestic" short-wave stations, meaning of foreign language phrases spoken in distant stations—how to erect special types of short-wave antennas, etc., and SILVER CUP TROPHY for best photo of readers listening "shacks."

From this, you will see that the magazine has been designed as a companion magazine to reader of SHORT WAVE CRAFT magazine. You will not wish to be without THE SHORT WAVE LISTENER MAGAZINE. The new magazine will help you tremendously in your hobby. **As you cannot get anywhere else.** So, solve the information, such as you have here today. THE OFFICIAL SHORT WAVE LISTENER MAGAZINE, in other words, is a necessity.

What You Will Find in the New Official SHORT WAVE LISTENER MAGAZINE

Over 800 short-wave stations in various parts of the world await the touch of a finger on the tuning dial of your "short" or "all wave" receiver.

Among the 800 odd short-wave stations there are many aboard ocean going ships, and from the short wave broadcast stations in Europe, Asia, Africa, Australia, and South America, not to mention the United States and Canada, there are nearly 300 stations calls, giving regular short-wave program service.

The new SHORT WAVE LISTENER magazine contains the following valuable features, which every short-wave "fan" cannot afford to miss!

Photos, and descriptions of short wave broadcasting stations in various parts of the world, with photos of short wave stations.

Where to find the important short-wave "DX" stations on the dial of your receiver.

Verification cards—what they are and how to get them.

Up-to-the-minute gram list of short-wave stations of the world with call letters and frequencies, including "Police,"

and "Airtone" short-wave stations. Special list of the best of star short-wave stations, with their frequencies and call letters. Valuable hints to the "short-wave listener"—how to locate the "weak" distance stations, etc. Different time zones, in various parts of the world together with a map showing the location of short-wave stations. "Best time to listen in" by M. Harvey Gernsback. How to identify short-wave stations by their "musical notes" signatures. Question and Answer department for the Short-Wave Listener. Notes on "foreign" as well as "domestic" short-wave stations, meaning of foreign language phrases spoken in distant stations—how to erect special types of short-wave antennas, etc., and SILVER CUP TROPHY for best photo of readers listening "shacks."

THE OFFICIAL SHORT WAVE LOG AND CALL MAGAZINE, of which the first issue has been published, will hereafter come out every other month under the name of **Short Wave Listener MAGAZINE**.

OFFICIAL Short Wave Listener MAGAZINE

HUGO GERNSBACK

I have created an entirely new magazine for the short wave listener, such as has not existed before. This new magazine is totally different in get-up and contents from the former magazine, and nothing like it has ever been published before.

To begin with, the new magazine comes with a four-color cover that is beautifully printed throughout. It contains a great variety of material, all of which is essential today to the short wave listener.

Receiving Antenna

The receiving antenna is a separate galvanized pipe of approximately the same length. A single wire feeder is taken from the top end of the antenna itself and run from a point approximately 25 ft. above the roof, which would be the 46th floor of the hotel, to the room which is used for the station, which is on the 43rd floor. Other antennas in approximately the same position, with the Lynch Giant Killer Cable acting as the transmission line, have provided about the same receiving results, employing the same receiver, with the advantage of a noticeable decrease in background noise. A standard National SRR receiver is employed and the output is used to energize a "permanent magnet" dynamic loudspeaker.

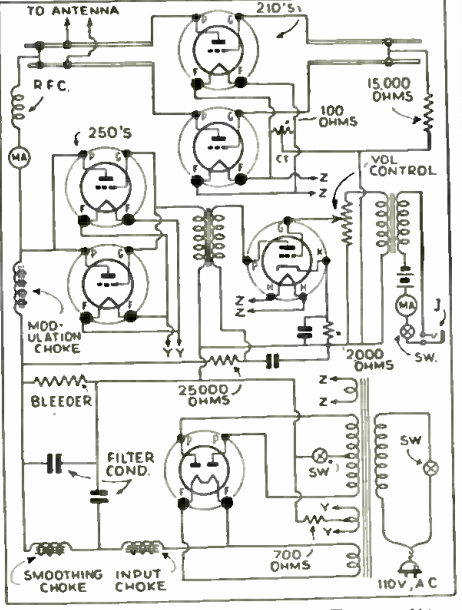

Hotel "New Yorker" 5 Meter Transmitter

Ready-Made Aerial Kit

● READY-MADE suits? Well, here's a ready-made antenna! Believe it or not, this antenna is entirely constructed and all you have to do is put up two poles, or what have you, and fasten it in place. There are two types shown as in the diagrams, one is a balanced doublet system, and the other is the inverted "L" type, or more commonly termed "Zepp." The balanced doublet, as well as the Zeppelin type, uses a "feeder system" using heavy rubber, twisted pair. The Co-Ra-Co kit consists of a coupling transformer, 46 feet of aerial wire, 54 feet of transmission lead-in wire, three standard porcelain insulators, a porcelain entrance tube, four porcelain nail knob insulators, one ground clamp and 15 feet of ground wire; complete instructions are furnished with each kit.

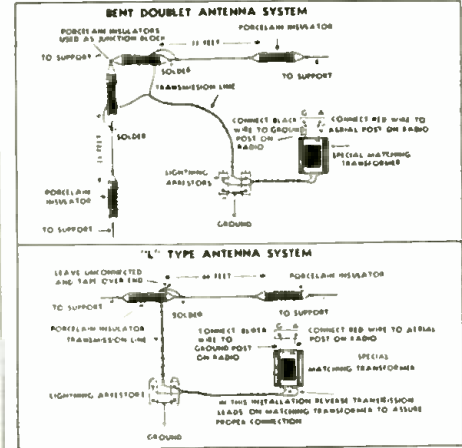

Hook-ups for "doublet" and Inverted "L" aeriels which can be erected in a jiffy with new Co-Ra-Co "Kit," (No. 260)



No ONE can yet say how far-reaching will be the effect of radio on modern living and business—but every one is agreed the industry is still in its infancy . . . that its possibilities are unlimited!

This is why the wisest counselors are advising young men to acquire the fundamentals of radio . . . to prepare themselves for the opportunities ahead. The future is exceedingly bright.

Thousands are finding exactly what they need in the International Correspondence Schools' Radio Course. So can you! Prepared by experts, and frequently revised by them, this course has the enthusiastic approval of the industry.

There is a consistent demand for radio mechanics, assemblers, testers, inspectors, draftsmen, service men, installers and salesmen; also, for operators and attendants on board ship and at commercial radio stations, government police stations and aviation stations. The field of opportunity is unlimited. Let us send you complete information—absolutely free. Use the coupon. Mail it today—Radio beckons you.

INTERNATIONAL CORRESPONDENCE SCHOOL

"The Universal University"
BOX 2880-B, SCRANTON, PENNA.

Without cost or obligation, please send me a copy of your booklet, "Who Wins and Why," and full particulars about the subject before which I have marked X:

RADIO OPERATING
 RADIO SERVICING
 ELECTRICAL ENGINEER

Electric Wiring
 Electric Lighting
 Welding, Electric and Gas
 Telegraph Engineer
 Telephone Work
 Mechanical Engineer
 Mechanical Draftsman

Machinist
 Gas Engines
 Diesel Engines
 Aviation Engineer
 Civil Engineer
 Refrigeration

Name _____
Age _____
Address _____
City _____ State _____
Occupation _____

If you reside in Canada, send this coupon to the International Correspondence Schools Canadian, Limited, Montreal, Canada.

Please mention SHORT WAVE CRAFT when writing advertisers

ANNOUNCING THE NEW PROFESSIONAL-"3" ALL-WAVE AIR SCOUT

"Only Set of Its Kind In the World"

INVENTED BY H. G. CISIN

Pat. Pending
U.S. Serial
No. 592,586



Superlative 3-Tube Performance!!

CERTIFIED RECEPTION of Australian, Asiatic, South American and European stations reported. Hundreds of letters on the graining Air Scout. Case CHIX circuit, two tubes in one envelope giving pentode regenerative detection, triode audio amplification. Special tube for rectification. Built-in power supply. No batteries. Operates from any 110-volt A.C. or D.C. house lighting circuit. Uses ordinary aerial. Beautiful black crystalline-metal panel. Newly invented coil frame. Calibrated dial. Low-loss parts used exclusively. All controls on front panel. Coils for 10 to 215 mc. & instructions included. Workmanship, materials, performance guaranteed.

KIT ASSEMBLED	\$5.95
Wired and Laboratory Tested Extra	\$1.45
Aeratus Tubes	1.25
Broadcast Coil95
Lightweight single earphone50
Double Earphones	1.20

Free circulars available on nine amazing Air Scout models.

ALLIED ENGINEERING INSTITUTE
98 Park Place Dept. S-15 New York, N. Y.

Here It Is! Martin JUNIOR

Think of it!
A Genuine
Martin
Vibroplex
for only \$10

For Limited Time
ONLY

\$10

BUY NOW

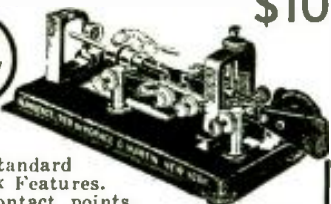

All Standard Vibroplex Features.
Heavy contact points.
2 3/4 pound black Japanned base. The only difference is in size. A great bug for radio and a great bargain at this low price. Easy to use. Order now before it is too late. Money order or registered mail. Write for catalog.

THE VIBROPLEX CO., Inc., Dept. SW-2
825 Broadway New York, N. Y.

Cable Address: "UncleDave." 20% Deposit with C.O.D. Orders.
Write for new Ham Catalog—just off the press!

UNCLE DAVE'S RADIO SHACK

Peerless 40-DX Transmitter, 35 watts output CV 10 watts phone, a beautiful job at an extremely low price. Write for details.
Sprague resistance coupled speech or P.A. amplifier, 3 1/2 watts output, finest of components, uses 245-280, ONE MONTH ONLY \$4.95
4" genuine Bakelite dials, five for \$1.00
Turner Crystal Microphones high output, flat response, new type, Special \$11.75
WRITE FOR INFORMATION ON THE NEW REVOLUTIONARY PEERLESS BROADCASTING THREE RECEIVERS, NATIONAL, IRO AND HAMMARLUND SUPER-PROS IN STOCK.

RADIO ENGINEERING,

broadcasting, aviation and police radio, servicing, marine radio telegraphy and telephony, Morse telegraphy and railway accounting taught thoroughly. Engineering course of nine months' duration equivalent to three years of college radio work. All expenses low. Catalog free. School established 1871.
Dodge's Institute, Turner St., Valparaiso, Ind.

"Tin-Can" 4-Tube Set

(Continued from page 598)

The coil forms are rather unique in construction. A 4- and a 5-prong tube base are used for each form. The 4-pronged base is cut, as shown in the drawing, to form a handle. The two tube bases are fastened together with a 3/4-inch length of 1 1/4-inch O.D. thin-walled bakelite tubing and ambroid cement. Four coils will be used. You will need four of both the 4- and 5-pronged bases. You will also need one for the cable connector. The coils are wound according to the data on the winding chart and are all wound in the same direction. Be sure to connect them as shown on the coil drawing. In the aerial circuit the antenna is coupled through a 2.5 M.H. R.F. choke, such as National or Hammarlund.

The split stator variable condenser is made from an old low-loss condenser. The stator is split as shown in the photograph. The low-capacity section has two plates and the other section has four plates. This last section is automatically switched in by a "jumper" wire inside the coil itself. This jumper wire is used in only the two low frequency coils. The capacity of the 2-plate section is 100 mmf. and that of the 4-plate section is 200 mmf. If a condenser of the type mentioned is not available, one may be bought with the stator already split and of the correct capacity.

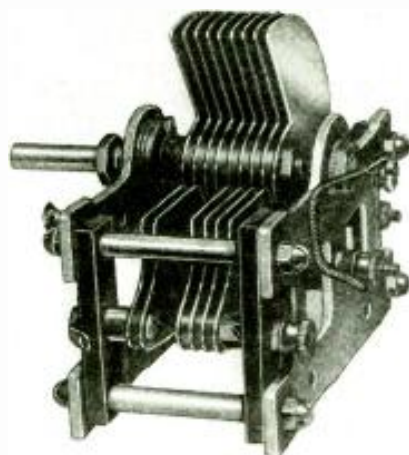

This photo clearly shows how an old broadcast condenser was remodeled for the "Tin-Can" set.

Probably the best filament supply is a 2-volt Air Cell battery. On a set of this size it will last for a long time with no trouble whatsoever. I used one good cell from an old storage battery and even with a 2-volt dial light, that uses nearly as much current as all the tubes in the set, it has lasted me better than a month without being charged. One could use dry cells, providing a rheostat was inserted in one of the filament leads. However, in using dry cells, one must be careful that the 2-volt filament rating is not exceeded. Turn up the rheostat until the tube filaments just glow red.

B-batteries may be used for plate supply, but I found it much cheaper to buy a used "B" eliminator. Electrolytic condensers of four to eight mf. capacity across the terminals, eliminated all hum. A small 22-volt B-battery was used for the C-bias.

When you have the set connected up, advance the regeneration control until a rushing or hissing sound is heard. Then tune the set until the station carrier whistle is heard. The regeneration control is then backed off until the signal clears up. If you are using a "B" eliminator on this set, it may take some experimentation to find the correct screen-grid voltage to give smooth regeneration and maximum volume.

Your author has used this set for some

FREE!

1935 EDITION

108 Page RADIO

and SHORT WAVE TREATISE

Over 100 Hook-Ups

More Than 1,500 Illustrations



A Veritable Text Book

NOT JUST ANOTHER CATALOG

This completely revised and enlarged 1935 edition contains 108 solid pages of useful radio information, diagrams, illustrations, radio kinks and real live radio merchandise. It contains more valuable radio information—more real live "meat"—than many textbooks on the subject. Its usual considerable space has been devoted to the beginner in radio.

PARTIAL LIST OF CONTENTS

Chapter Two of "Fundamental Principles of Radio for the Beginner"—The New Tubes, Their Uses, and Their Fundamental Circuits—How to Make Money with Public Address Systems, How to Install and Maintain Them—How to Revamp Six-Volt Battery Sets to Use Two-Volt Tubes—Prize Winning Kinks and Short Cuts in Radio—How to Build the "B" Beginner's Transmitter—How to Build the Famous Amateur Radio Wave Receiver—How to Construct a Complete Tube Chart Including Socket Connections for all Tubes—Numerous Free Offers, etc., etc.

WRITE TODAY

Enclose 3c coin or U.S. stamps for postage. Treatise sent by return mail.

RADIO TRADING CO.
101A Hudson Street, New York City

SEXOLOGY

THE MAGAZINE OF SEX SCIENCE

SEXOLOGY, foremost educational sex magazine, is written in simple language and can be read by every member of the family. It is instructive, enlightening—not a risqué book—contains no offensive matter.
Contains 25 important articles on Sex Science, 64 pages, with attractive two-color cover. Here are a few of the more important articles:
"Sex Superstitions"—Poverty and Sex Immorality (Illustrated)—Gonorrhea Mistaken for Appendicitis (Illustrated) Contraceptive Delusions in Men—The Nature of the Sexual Climax—Radium Treatment of the Womb (Illustrated)—Bisexuality (Desire for Both Sexes)—Functioning of the Testes (Illustrated)—Movies and Morals—Questions and Answers.

Get a copy of SEXOLOGY on a 3c post-paid, or, if your dealer cannot supply you, send 25c cash or stamps for current issue.

SEXOLOGY
95 Hudson St. New York, N. Y.

RADIO'S LIVEST MAGAZINE

Edited by HUGO GERNSBACK



RADIO.CRAFT is devoted not only to the radio experimenter and technician, but also to the beginner in radio. Picture diagrams simplify construction of sets. Kinks show simple ways out of difficult problems. The latest radio equipment is illustrated and described.

RADIO.CRAFT is fully illustrated with photographs, diagrams and sketches. Each issue contains over 150 illustrations. 15c for Sample Copy.

8 Months for \$1.00

RADIO-CRAFT
99C Hudson Street New York, N. Y.

PATENTS — TRADE MARKS

All inventions submitted held confidential and given personal attention by members of the firm.
Form "Evidence of Conception" and instructions
"How to Establish Your Rights"—Free
LANCASTER, ALLWINE & ROMMEL
PATENT LAW OFFICES
475 Bowen Bldg. Washington, D. C.

DATAPRINTS

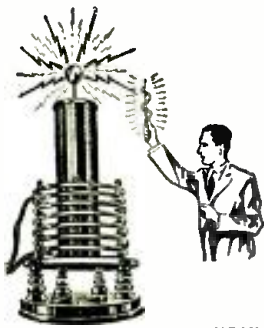

Just the
Technical
Information
You Need
To Build
Electrical
Apparatus

TESLA OR OUDIN COILS

- Dataprint containing data for constructing this 3 ft. spark Oudin-Tesla coil. Requires 1 K.W. 20,000 volt transformer as "exciter". \$.75 see list below. Includes condenser data.
- 8 inch spark, data for building, including condenser data; requires 1 K. W. 15,000 volt transformer; see list below. 0.50
 - Violetta type, high frequency coil data; 110 volt A.C. or D.C. type; 1" spark; used for "violet ray" treatments and "Experiments". 0.50
 - How to operate Oudin coil from a vacuum tube oscillator 0.50
 - 3 inch spark Tesla coil; operates on Ford ignition coil 0.50
 - 3 inch spark Oudin coil; 110 volt A.C. "Kick-Coil" 0.50
 - 20 Tricks with Tesla and Oudin Coils. 0.50

TRANSFORMER DATA

- 1 k.w. 20,000-volt transformer data, 110-volt, 60-cycle primary. Suitable for operating 3 ft. Oudin coil 0.50
 - 1/2 k.w. 15,000-volt transformer data, 110-volt, 60-cycle primary. Suitable for operating 8-inch Oudin coil 0.50
 - Electric Welding Transformer (State secondary voltage) 0.50
 - Induction Coils—1 to 12 inch spark data. 0.50
- NEW! RADIO AND TELEVISION. \$0.50 Each (Send for List.)



SLIDE RULE MIDGET

Metal 4" Dia.
Price \$1.50.

Case 50c extra

This rule solves any problem in multiplication, division, addition, subtraction, and proportion; it also gives roots and powers of numbers, sines, cosines, tangents and cotangents of all angles; also logs of numbers. Adds and subtracts fractions. Approved by colleges.

10" Dia. 27" Scale "Special" Rule. \$2.75.
Multiplies and Divides, but has no "Trig" Scales.

TELEGRAPHONE — Records Voice or "Code" signals on steel wire by magnetism. Code can be recorded "fast" and translated "slow." Construction data (special) \$0.50

MAGNET COIL DATA

- Powerful battery electro-magnet; lifts 40 lbs. \$0.50
- 110 Volt D.C. magnet to lift 25 lbs. 0.50
- 110 Volt D.C., 300 lb., lift electro-magnet. 0.50
- 110 Volt D.C. solenoid; lifts 2 lb. through 1 in. 0.50
- 110 Volt D.C. solenoid; lifts 6 lb. through 1 in. 0.50
- 12 Volt D.C. solenoid; lifts 2 lb. through 1 in. 0.50
- A. C. Solenoid, powerful, 110-volt, 60-cycle. 0.50
- MOTOR—1/16 H.P., 110 volt A.C., 60 cycle (suitable for driving 12" fan, etc.)—Data. 0.50
- 60 or 1,200 cycle Synchronous motor. 0.50

MISCELLANEOUS DATAPRINTS

- Treasure Locator \$0.50
- 2 K. W. 110 vt. to 18 vt. transformer data. 0.50
- 20 motor circuits—hook-ups 0.35
- 20 practical telephone hook-ups 0.35
- 100 mechanical movements for inventors. 0.50
- Polarized Relay—Ultra Sensitive 0.50
- Electro-medical coil (Shocking coil). 0.50
- Water-Wheels—How to Build and Light your house 0.50
- 20 Electric Bell circuits. 0.50
- Public Address System 0.50
- Electric chime ringer; fits any clock. 0.50

20 "Electrical Tricks" for LODGES and PARTIES \$0.50

How to Fry Eggs on Cake of Ice Electrically. \$0.50
"Rewinding" Small Motor Armatures. 0.50
"ENGINEERING SERVICE BY MAIL"
Send Sketch of Your Problem for Estimate.
(20% off on orders for \$3.00 or more. No C.O.D.)

The DATAPRINT COMPANY
Lock Box 322 RAMSEY, N. J.

time and has found it satisfactory in every way. The loud-speaker is used on 90 percent of the stations. Headphones are necessary only on the weakest signals. While we are on the subject of ear phones, let me remind you not to use them directly across the output of this set. The high plate current, drawn by the pentode tube, will soon destroy the magnetism in the ear phones. It is best to use the output transformer or output coupling device on both ear phones and loud-speaker units. Any output transformer, that was made for the old type '12 or '10 tube, will work satisfactorily with a pentode tube.

You will find this a set to be proud of as it is very presentable in appearance and operation. Its one best feature is its very low cost.

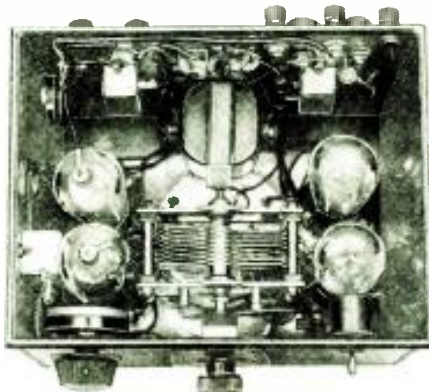

Inside view showing the placement of parts in this compact 4-tube receiver.

Parts List for Tin-Can Radio

- 1—1 meg. resistor. Lynch.
- 1—Tuning condenser (see text). 140 mmf.
- 2—.1 meg. resistor. Lynch.
- 1—.5 meg. resistor. Lynch.
- 1—3,000 ohm resistor. Lynch.
- 2—.001 mf. by-pass condensers. Aerovox.
- 3—.5 mf. condensers. Aerovox.
- 1—.00025 mf. by-pass condensers. Aerovox.
- 1—.00025 mf. mica condenser. Aerovox.
- 1—2.5 millihenry R.F. choke. National.
- 4—4-prong wafer sockets. Na-Ald.
- 1—5-prong wafer socket. Na-Ald.
- 1—audio transformer (3:1 ratio).
- 1—output transformer, optional.
- 1—set of plug-in coils, standard 4-prong; Na-Ald (Bud).
- 2—type 32 RCA Radiotrons.
- 1—type 30 RCA Radiotron.
- 1—type 33 RCA Radiotron.

PLUG-IN COIL DATA

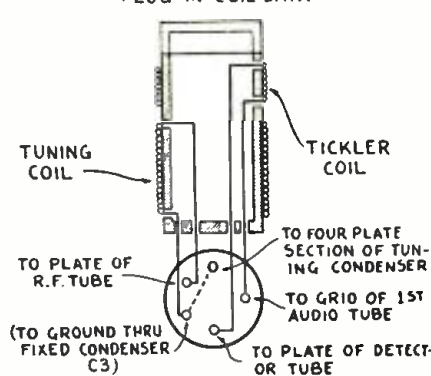

COIL	SEC.TURNS	TICKLER TURNS	WIRE SIZE
# 1	78	35	36 D.S.C.
# 2	35	22	24 D.S.C.
# 3	22	12	20 D.S.C.
# 4	13	10	20 D.S.C.
# 5	7	6	20 D.S.C.

JUMPER ON COILS #1 AND #2

Coil data for the "Tin-Can" set.

MAKE YOUR RESERVATION FOR
WORLD WIDE RECEPTION
IN THE ANKER LINE!

ALL-WAVE SUPERHETERODYNE "DREADNAUGHT"



QUICK FACTS

- Continuous band spread.
- Standard parts used throughout.
- Easily lined up. I.F.'s prealigned.
- 7 tube all wave super-heter circuit.
- Built in Beat oscillator.
- Power supply also built in.
- 9 1/2 to 550 meter range.
- Hi-ratio airplane dial tuning.
- Tone and static control.
- Hi signal to noise ratio.
- Built in Beat oscillator.
- Power supply also built in.

Foundation Kit consisting of drilled "Dreadnaught" chassis and black cracked panel, coil shield, and complete directions including schematic and pictorial diagrams. **Net Price \$1.95**
The remaining material can be bought when needed.

Complete Kit, including all necessary parts, 4 pairs of plug in inductances 9.5 to 200 meters, hardware, diagrams, etc., etc. List **\$49.85** **\$29.91 NET**

LESS TUBES AND SPEAKER.
Wiring and Testing \$6.75

ANKER-CRUISER

3-TUBE A.C.-D.C. SET

WORLD-WIDE RECEPTION

KIT
\$10.45 NET



OUTSTANDING FEATURES

Electron coupled feedback, 3 tubes, 6C6, 43, and 25Z5, humfree built-in 110 V. AC-DC power supply, front panel plug-in coils, front panel phone plug, automatic speaker cutoff, hinged cover black cracked metal cabinet, 13 to 200 meters—complete kit of parts, including 4 front plug-in coils, hardware, diagram, instructions, etcetera. List, \$17.41; net, \$10.45. Wiring and testing, list, \$3.40; net, \$2.05. Broadcast coil list, \$9.95; net, \$5.95. Kit of Arcturus Tubes, list, \$3.95; net, \$2.37. Ankerlite phone, list, \$1.75; net, \$1.05.

Order from this page.
Free Anker Catalog on Request

ANKER LABS

20 W. 22nd St., Dept. S-2-35, New York City

WORLD WIDE ALL WAVE RADIO



A real powerful long and SHORT WAVE Radio Receiver that actually gets local and foreign broadcasts, police, amateur, airplane, etc., transmissions direct! Thousands now in use. Owners report reception of Foreign Stations with amazing volume. Works on two inexpensive batteries. Not a toy! RESULTS GUARANTEED!

\$1.95

ACE construction kits have all necessary parts mounted on attractive metal chassis and panel, all ready for wiring. Clear picture diagrams. Wire it yourself. It's easy. Range 15 to 600 meters. Complete Kits, with coil—

- ONE TUBE KIT, \$1.95
- TWO TUBE, \$2.85

ALL ELECTRIC 105-125 Volt AC-DC two-tube house current set. No batteries needed! Complete Kit. \$3.65
Kits wired, 75c extra. Tubes, 85c ea. Double phones, \$1.25
ORDER NOW. Send \$1. balance C.O.D. or if full remittance with order, we pay postage. Free literature.

FREE!! Short Wave data, etc.! Send 10c for handling, NOW!!

ACE RADIO LABORATORIES

1619 Broadway Dept. C-2 New York City

WANT A TELEVISION JOB?

Radio and Television are packed with romance. Every hour interesting and immensely profitable. For free details write First Nat'l Television, Power & Light Bldg. Kansas City, Mo., Dept. BB-2

1935 DOERLE - Standbys ★★

DOERLE 2-TUBE MODELS



**A.C.-2 VOLT
and D.C. Models**
15 to 200 Meters
3-Tube Performance

Only **\$7.75**
Less Tubes

These 2-tube receivers are low in price—yet, inexpensive as they are, they pull in short-wave stations from all over the world, in practically any location, not only in this country but anywhere.

Available in three different models. The 2-tube AC Doerle employs a 6PT duplex triode pentode (actually 2 tubes in one) as regenerative detector and first audio, followed by a 11 power pentode output tube. This model requires a suitable AC power pack for its operation. The 2-tube DC model employs the same complement of tubes but requires no power pack for its operation. It may be plugged in directly across the 110 volt DC line for immediate use.

The 2-tube battery model employs a type 30 as regenerative detector and a type 19 twin triode as two stages of AF amplification. Ship. wt. of all models—10 lbs.

All Models on Same Chassis

No. 5007K. "Doerle AC 2" Short-Wave Receiver Kit including Coils and diagram but less tubes and cabinet. **YOUR PRICE \$9.50**

No. 5008K. "Doerle DC 2" Short-Wave Receiver Kit, including coils and diagram. Less tubes and cabinet. **YOUR PRICE \$8.50**

No. 5009K. Doerle 2-Tube Battery Short-Wave Receiver Kit, less tubes, cabinet and batteries but including coils and diagram. **YOUR PRICE \$7.75**

Set of RCA Licensed Tubes for AC, DC, or 2-volt models per set \$1.70
Accessories: 15 volt "H" batteries, 98¢ ea.; No. 6 Dry Cells, 30¢ ea.; No. 2149 Hum-free Power Pack, \$5.50; Cabinet, 95¢.

WE WILL WIRE AND TEST ANY OF THESE KITS WHEN ORDERED FOR \$1.50

SEE PAGE 638 FOR OTHER SHORT-WAVE SETS

New 1935 Model 15 to 200 Meters

**DOERLE
4-TUBE
2-Volt
BATTERY
Receiver**

\$16.65

less tubes
& batteries



Built-In Speaker & Battery Space

4 Tubes, but Equivalent To 5-Tube Performance. Another stride forward! The ideal set for farm and suburban use where electricity is not available. It is also the ideal portable set. Take it where you will, there are no trailing wires, no separate power packs, or battery cables. **Everything is conveniently built into a single cabinet, hand-somely black crackle finished with airplane dial.** Not only that, but all short-wave stations are received on the loud speaker which is mounted right in the cabinet. A jack and switch arrangement in the back permits you to use earphones at will. The circuit is essentially the same as the "Doerle AC 2" shown on page 638 except that the equivalent tubes of the 2-volt type are employed. Namely: A type 31 variable-mu RF pentode followed by a type 30 regenerative detector; a type 19 twin triode tube (actually 2 tubes in one), and finally a 33 power pentode output tube. The 6" magnetic speaker is perfectly matched to this output tube. **This receiver is capable of receiving both phone and code stations.** It has built up for itself a very attractive hot in its trial tests. Requires 2 No. 1 dry cells (portable size), 3-15 volt (portable size) "C" batteries and 16 volts of "C" for operation. Ship. wt. (less batteries) 15 lbs.

No. 5003. Doerle 4-tube 2-volt Battery Receiver, including Magnetic Speaker and Plug-in Coils, less tubes and batteries. **YOUR PRICE \$17.95**

No. 5003K. Same Receiver in Kit Form, including Speaker, coils and diagram, less tubes and batteries. **YOUR PRICE \$16.65**

Complete Set of RCA Licensed Tubes \$3.85
Complete Set of Batteries, portable type \$5.95

FREE See pages 618 and 630 for our free catalogs.

RADIO TRADING CO., 101A Hudson St., New York City

16-Tube Has Range 9 to 2400 Meters

(Continued from page 600)

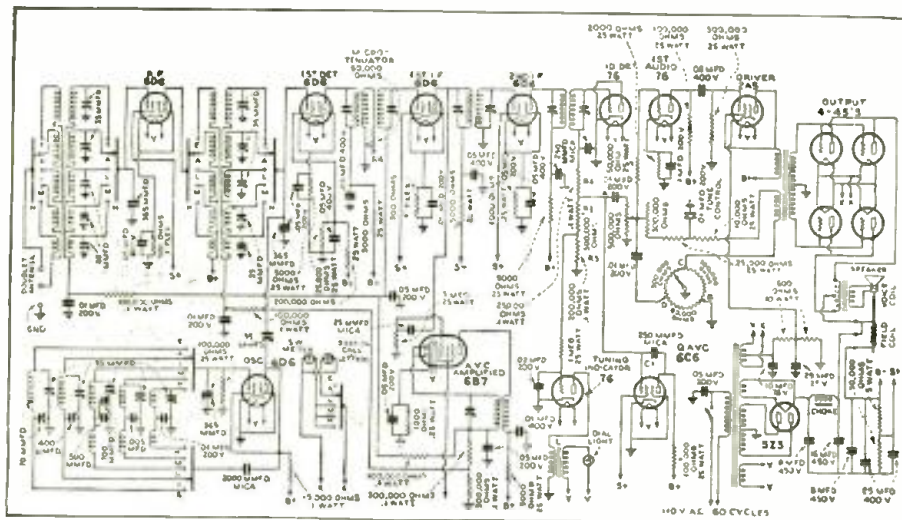

Diagram of Midwest 16 Tube "All-Wave" Receiver

6-Tube All-Wave Super-Het

(Continued from page 600)

control can be retarded, reducing inter-station noise. The control does not have to be advanced except for extremely distant stations. Where local noises are high the set sensitivity should be retarded, since full power cannot be used comfortably. Where local conditions are very favorable the gain of the receiver can be increased considerably before the noise level becomes objectionable.

The "Martian Eagle" has connections for a doublet antenna system as well as for single antenna with or without transposed lead-in. It also has a phonograph jack.

The pictures and circuit diagram are clear enough and need no explanation, with the possible exception of the oscillator grid coil. For the broadcast band the grid connection is at 1, C2 being the padding condenser. For the next band there is a jumper (in

the coil) between 1 and 2, with C3 as padding condenser. For the other two bands there is a jumper between 1, 2, and 3, no padding being required.

On the short-wave bands, "foreign" stations were received with almost ridiculous ease, among them Rio de Janeiro and Buenos Aires, Cuba, and Barranquilla. On the broadcast band not only does the "Martian Eagle" give complete separation of all locals, but Pacific coast stations have been received as early as 7:30 p.m.

List of Parts

Condensers

- 1 Three-gang condenser .00036 C
- 1 Trimmer condenser, C1
- 1 Insulante pad. condenser (500 mmf.) C2
- 1 Insulante pad. condenser (1000 mmf.) C3
- 2 .00025 mica condensers, C4
- 2 .1 200-volt condensers, C5
- 1 .1 400-volt condenser, C6
- 1 .5 400-volt condenser, C7
- 1 .25 200-volt condenser, C8
- 1 .5 200-volt condenser, C9
- 2 .05 200-volt condensers, C10
- 1 .0005 mica-condenser, C11
- 1 10 mfd. 25-volt condenser, C13
- 1 .02 400-volt condenser, C12
- 2 8 mfd. 500-volt condensers, C14

Resistors

- 1 50,000-ohm one watt, R1
- 1 300-ohm 1 watt, R2
- 1 50,000-ohm 1 watt, R3
- 1 150-ohm 1 watt, R4
- 1 2000-ohm potentiometer and switch, R5
- 1 8,000-ohm 2 watt, R6
- 1 10,000-ohm 5 watt, R7
- 1 100,000-ohm 1 watt, R8
- 1 500,000-ohm potentiometer, R9
- 1 5,000-ohm 1 watt, R10
- 1 150,000-ohm 1 watt, R11
- 1 500,000-ohm 1/2 watt, R12

Other Requirements

- 1 Set of 5-prong special wound Eagle coils
- 1 Set of 6-prong special wound Eagle coils
- 3 I.F. Trans. T465 KC. (Hammarlund)
- 1 Eagle Power transformer
- 1 Rola 1800-ohm speaker W/300 tap.
- 1 Eagle drilled chassis. Size 9 3/4 x 14 1/2
- 1 Eagle cadmium-plated bottom rack

Please mention SHORT WAVE CRAFT when writing advertisers

"MIRACULOUS!"

LYNCH HI-FI

TRADE MARK REGISTERED
(High-Fidelity)

ANTENNA SYSTEMS

Guaranteed to outperform any other aerial

"The Doubleday-Hill Electric Company of Pittsburgh reports that performance of the LYNCH HI-FI Antenna System is absolutely miraculous, as never before have they been able to demonstrate any short wave reception, but now they get practically everything that is on the air."

—FRANK A. BAUMGARTEN

PATENTED

for your protection. It cannot be duplicated by others. There is nothing "just as good." Don't accept substitutes because

"No Radio Can Be Better Than Its Aerial—No Aerial Is As Good As a LYNCH Aerial."

Full Information on Request

Arthur H. Lynch, Inc., 227 Fulton St., N. Y.
PIONEER OF NOISE-REDUCING AERIALS

Health Ray Carbon Lamp

PAYS FOR ITSELF IN A FEW TREATMENTS.



Table Model

Everyone in the family needs the health giving Violet Rays.

This is a large CHROMIUM plated lamp using standard carbons emitting rays of ultra violet and infra red.

If Sun Tan is desired, order accordingly.

Saves doctor's bills. Cures colds, rheumatism, and other ailments.

Size 11 1/2" high, 10" wide, 5 1/2" deep. Weight 8 3/4 pounds.

Interesting literature sent free.

List price with Screen and Goggles—\$10.00.

YOUR COST—F.O.B., N.Y.—\$3.38.

WONDERFUL VALUE!

Gold Shield Products Co., 98 Park Place, N.Y. City

Know Thyself!

Well Illustrated

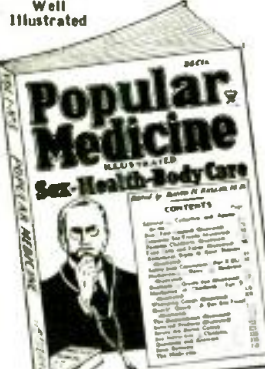

This new monthly magazine is also your own doctor. WHAT ALLS YOU? POPULAR MEDICINE tells and advises you thoroughly. Written for you by doctors. Non-technical yet authoritative for all laymen. Many anatomical illustrations.

Special Offer!

8 Months \$1 for 1

Send 25c for sample copy **POPULAR MEDICINE**

97C Hudson St., New York, N. Y. On All Newsstands

AUTOMATIC FURNACE REGULATOR

COMPLETE KIT.....\$39.50

With "Thermostat"

Includes wire, chain, pulley, damper control unit and Room Thermostat. Instructions. Save 1/4 to 1/2 Coal Bill.

DATAPRINT CO.
Box 322, Ramsey, N. J.

SPECIAL FOR THIS MONTH ONLY

Send \$1.00 (\$1.25 Canada and foreign) and we will send you **SHORT WAVE CRAFT** for Eight months. **DO IT NOW.**

SHORT WAVE CRAFT
99-101 Hudson Street New York

- 1 Phono jack
- 1 Triple antenna post for doublet
- 1 Line cord and plug
- 4 Screen grid clips
- 1 2A7 socket and tube
- 2 58 socket and tube
- 1 55 socket and tube
- 1 2A5 socket and tube
- 1 80 socket and tube
- 1 Five prong speaker socket
- 1 Five prong coil socket
- 2 Hammarlund coil shields
- 4 Tube shields
- 1 Crowe airplane dial
- Lugs, hardware, wire

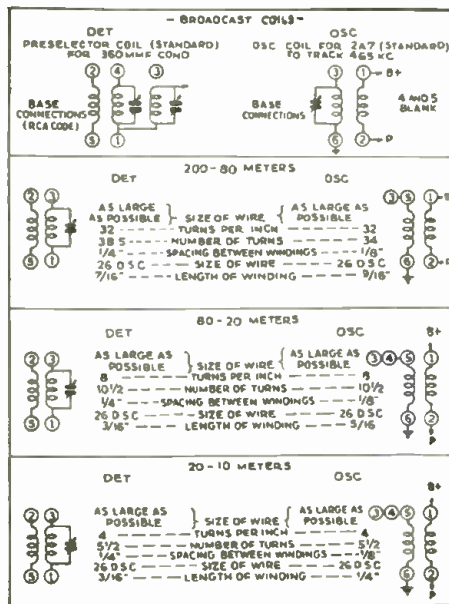

Paris Radio Exhibition
(Continued from page 593)

itive than most wave-change arrangements.

Another advantage of this system of all-wave receiver coil construction is in the flexibility—in the matter of how many coils can be included. In the arrangement, any desired number of coils can be switched in at the same time, to cover the number of tuned circuits required by the circuit. This is shown in the photo here which shows a unit having 3 sets of coils.

Practically all the receivers shown at the Paris show, according to *Toute la Radio*, that lively little French magazine, are superheterodynes, while considerable effort has been shown by manufacturers to improve the external appearance of the sets. There are quite a number of A.C.-D.C. models in evidence, though the majority are A.C. operated. Sets of the D.C. type were notable by their absence.

Goodbye Eiffel Tower

● WHEN the Lucerne agreement was signed the wave-length plan provided no channel for the Eiffel Tower station, and everyone assumed that it would be closed down forthwith. However, it just went on broadcasting and helping to make yet more chaotic the chaos that prevailed in Europe.

Some months ago it was announced that the Eiffel Tower was immediately to cease operations on the long waves and blossom out as a short-wave broadcaster.

Once again nothing happened; the Eiffel Tower just carried on as before. Now, the Minister of Posts and Telegraphs has at last taken charge. He announced a short time ago that the Eiffel Tower was clearly superfluous as a broadcasting station and that it was causing a great deal of unnecessary interference. It must be closed down and used in the future only for occasional experimental transmissions.

M. Mallarme, the Minister of Posts and Telegraphs seems to be a man of his word, for according to *Popular Wireless*, the station has not been heard since, though there is some speculation in the above magazine that the station will pop up again on the long waves. The old Eiffel Tower seems like King Charles, to be "an unconscionable time a-dying."

In Stock—Immediate Delivery
The NEW
PATTERSON PR-12



PR-12 (8-550)

56 Features . among them are:

- Full range 8 to 550 meters.
- Patterson Selector-Band Dial; airplane type; shows only band in use; microphermic 2 speed tuning; 10 to 1 and 50 to 1 reduction; anti-backlash rubber drive.
- New 6 section tuning gang condenser gives an exceptionally low C tuned circuit, resulting in extremely high gain (approximately twice) on the short-wave bands, equalling or surpassing plug-in coils.
- Newly designed coils, with new type of switch, lowering the amount of dielectric loss and skin effect in tuned circuit.
- Pre-selection ahead of first detector results in higher signal to noise ratio, decreasing amount of image response to a minimum; increasing sensitivity, overall gain and selectivity.
- Modulation and R meter.
- Crystal filter, which can be cut in as a series or parallel filter; affords two degrees of selectivity, further raising signal to noise ratio and increasing selectivity.
- Monitor switch, for use in checking quality of your own transmission percentage of modulation indicated visually and orally.

NOTE: ● indicates NEW; ●●● indicates NEW and EXCLUSIVE!

NET DELIVERED PRICES
Complete (absolutely nothing else to Buy!)

PR-12 Crackle cabinet without crystal..... \$82.00

PR-12 Console without crystal..... 99.65

PR-12 Crackle cabinet with crystal..... 87.90

PR-12 Console with crystal..... 105.55

Chassis also available

SARGENT

8-31—15 to 560 meters, 8 tube super-het complete with tubes, speaker, etc. \$49.50

Marine model—same as 8-31 except for tuning range 15 to 1500 meters, complete 57.50

Peak Pre-selector..... \$19.80

Patterson Pre-selector..... \$17.64

McMURDO SILVER

The new 10P—Phone-CW Transmitter..... \$119.70

With all accessories—RK19, RK20, 53, 2A5, 80 Billye crystal and holder, Turner crystal "Mike" and stand—complete 150.50

SHIPPED PREPAID if full purchase price accompanies your order.

Send for our bulletin "Amateur Transmitter" which lists and describes "Everything for the Ham"

L. I. MARINE & ELECTRIC CO.
W 2 G O T — W 2 R G O
163-18 Jamaica Ave., Dept. 5235, Jamaica, N. Y.

PROVEN DEPENDABLE
PROFESSIONAL
BAND SPREAD AC5



- BUILT-IN DYNAMIC SPEAKER
- CONTINUOUS BAND SPREAD
- SELF CONTAINED AC VOLTAGE DOUBLER POWER SUPPLY
- 5 DISTINCT WAVE BANDS
- BUILT-IN COIL HOLDER RACK
- HIGH SENSITIVITY AND SELECTIVITY
- AEROPANE DIAL
- MANUAL ANTENNA CONTROL
- HIGH FIDELITY
- 5 NEW TUBES USED
- ALL WAVE BANDS VERY EASY TO CONSTRUCT

Complete kit including Dynamic speaker, power supply, coils from 11 to 200 meters, coil holder rack and complete instructions. Special Offer

\$14.95

Black crackle finished metal cabinet \$2.50

Kit of matched ARCTURUS tubes 3.10

Broadcast coil, 200-550 Meters 95

If you prefer it Custom Built, add 2.50

ORDER FROM THIS AD NOW AND SAVE

WORLD TROTTER RADIOD LABS.
168 Washington St., Division C3,
New York, N. Y.

Special Sale!

SHORT-WAVE RECEIVER

Complete Kit of Parts with Instructions and 4 coils

\$1 95

Wired and tested extra50c
RCA licensed tube40c

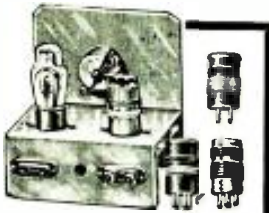

Accompanying prints and detailed instructions inform the builder the entire procedure as to how the receiver is to be assembled and wired.

Uses the low current consuming 230 tube; 1-45 volt and 2 No. 6 dry cells for operation. The receiver will cover the 15 to 200 meter bands with the four coils furnished.

FREE Catalog of many other Radio Bargains. Prices guaranteed **LOWEST**. Wait for our book before you purchase a receiver.

PROMPT RADIO SERVICE CO.
130-S Cedar St., New York, N. Y.

It's NOW

EVERYDAY SCIENCE AND MECHANICS is the finest scientific-technical-mechanical-constructional magazine in the field. Up-to-the-minute with news flashes of scientific events. Dozens of constructional articles and many popular experiments. Ideas from which you can make things to sell. A HOST OF INTERESTING SUBJECTS COVERED:—Woodworking—Photography—Magic—Patents and Inventions—Book Reviews—Metal-working—Chemistry—Engineering—Microscopy—Electrical Experiments—Household Helps—Astronomy—Prize Contests—other subjects.

10c

Edited by **HUGO GERNSBACK**

Get your copy today!
On all newsstands

10c
the copy

Over 150 Illustrations

Vest Pocket SOLDERING IRON



Smallest good iron now on the market. Will do the work of irons twice its size. Only 10 inches long, 1/2 inch in diameter. By using the highest grade elements, it heats up in half the time of ordinary irons. Guaranteed to give satisfaction or money back. We issue no catalog on this item. Enclose \$1.20 and iron will be sent postpaid in U.S. 10c extra in Canada.

Gold Shield Products Co., 98 Park Place, N.Y. City

1935 RADIO CATALOG

Free Book

All models: AC-DC midsets; dual and world-wide all-wave, farm, battery and car—at factory prices! Write for 21-page Bargain Catalog and 30-DAY TRIAL plan. Prices from \$9.95 UP.

AGENTS WRITE!

GOLDENTONE RADIO CO.,
123 Oakman Bldg. Detroit, Mich.

3 Tubes = Six Super-Het

(Continued from page 591)

transformer. Adjust these slowly with a screw-driver for maximum volume; proceed in the same way with the second and third I.F. transformers. During these operations the volume control should be nearly at maximum. After this preliminary line-up, note the meter reading. Detune the set slightly with the main tuning control. The meter reading should go up as the set is tuned away from the station. Tune the station in again and repeat the lining-up procedure of the I.F. transformers; watch the meter reading and adjust the set screw for minimum current on the meter. If the station is fading, the meter will fluctuate continually during the operation and it will be necessary to take an *average* reading on the meter. Repeat the lining-up procedure once more to insure accuracy and then leave it set. Next check the tracking of the oscillator coil. As mentioned before it is only necessary to take turns off the oscillator coils covering the two highest wavelength ranges. The 49 meter coil should have had 1 1/2 turns removed already, as mentioned in the paragraph on lining up the I.F. stages. Set the antenna trimmer condenser at the half-closed position and turn the main tuning control preferably to a point near where the rotary plates of the condenser are half way into the stationary plates. Tune in a station near this position (if one can be found). If no station is heard tune to the 49 meter band. If it comes in with maximum strength (as indicated on the meter by *lowest* reading) when the antenna trimmer is near the half-way closed position, no further alteration of the coil is necessary. If the resonance point is near maximum capacity on the trimmer, remove more wire from the grid winding of the oscillator plug-in coil, 1/2 turn at a time; 1/2 turn, or at most 1 turn, will bring the coils into line. Removing this wire will result in the station coming in at a position on the main tuning dial several degrees away from the former position, so that it is necessary to retune the main dial to pick up the station after the wire is removed from the coil. The largest coil set should be altered in a similar manner. With this set start by removing 4 turns from the oscillator grid winding. In the original set it was found necessary to take off 6 turns before success was achieved. The coils for the first detector are not altered in any way.

Tuning Hints

Tuning is very simple as all that is necessary is to turn up the volume control, set the trimmer for maximum *noise-level* and then tune the main control till a signal is picked up. A slight adjustment of the trimmer (the trimmer is quite sharp in tuning) will bring in the signal loud and clear; *volume* is adjusted to suit the listener. The A.V.C. will hold a fluctuating signal fairly steady, making it unnecessary to continually adjust the manual volume control.

All the principal European short-wave "broadcasters" (musical and other programs) have been heard on this set with excellent volume and low "noise" background. Several "foreign" amateur phone transmitters have been heard in the 20 meter band, as well as numerous South American broadcasters near 49 meters. Selectivity is very good (GSA at Daventry, England on 6050 kc. can easily be separated from W8XAL Cincinnati, Ohio, only 10 kc. removed from GSA), W8XAL has a very powerful signal in New York and it is difficult to separate from GSA. The quality of reception is very good, due partially to the fact that the second detector is a *diode*.

Parts List

- 2—Sets 5 prong plug in coils 15-200 meters. 4 coils to a set. (Na-Ald).
- 1—Dual gang midset variable condenser 140 mmf. per section (Hammarlund)
- 1—Midget variable condenser, trimmer, 50 mmf. (Hammarlund)

(Continued on page 637)

Please mention SHORT WAVE CRAFT when writing advertisers

BETTER WORLD • RADIO RECEPTION

More and Clearer foreign stations

with the

RCA WORLD-WIDE ANTENNA

Free your short-wave reception from the interfering noises of street cars, automobiles and electric motors with this scientific, double-doublet antenna system! Attractive appearance—easily installed! Price \$6.00, plus installation.

Ask your dealer or service engineer for a *Certified Installation*, or write for the FREE booklet: "Antenna Facts" to RCA Parts Division, Dept. W., Camden, New Jersey.



Sensational Results

**THOR'S
RGH-4
WINNER**



Designed by "BOB" HERZOG
Chief Engineer, THOR RADIO CO.
A COMPLETE A.C. SET

Covers Police Signals, Foreign Stations, Ship-to-Shore, Amateur and Broadcast Bands.
Loud Speaker Volume.

Complete Kit of Highest Quality Parts, including 8 Short Wave Coils

\$10.95

6 in. Dynamic Speaker \$2.00 extra.

FREE KITS MOUNTED FREE

Kits Shipped Redi-Mounted for Easy Wiring
It's a Cinch to Build it—You Can't Go Wrong

THOR RADIO COMPANY

167 Greenwich St. Dept. U New York
MAIL ORDERS FILLED
FREE TECHNICAL DATA

ALUMINUM PANELS

16 Gauge 7x12, 28c; 7x11, 32c
5/64 inch or 13 Gauge 7x10, 29c
7x12, 34c; 7x11, 41c; 7x18, 49c; 7x21, 68c

These panels are a special lot at the above prices. Longer and wider at correspondingly low prices. Add postage on 2 lbs. for each. We do not publish a catalogue. Estimates gladly furnished on request. Radio parts for over 10 years.

BLAN THE RADIO MAN, Inc.
177 Greenwich St. Dept. S-2 New York, N. Y.

... SHORT WAVE ESSENTIALS FOR MEMBERS OF THE SHORT WAVE LEAGUE ...

A FEW WORDS AS TO THE PURPOSE OF THE LEAGUE

The **SHORT WAVE LEAGUE** was founded in 1930. Honorary Directors are as follows:

Dr. Lee de Forest, John L. Reinartz, D. E. Replogle, Hollis Baird, E. T. Somerset, Baron Manfred von Ardenne, Hugo Gernsback, Executive Secretary.

The **SHORT WAVE LEAGUE** is a scientific membership organization for the promotion of the short wave art. There are no dues, no fees, no initiations, in connection with the **LEAGUE**. No one makes any money from it; no one derives any salary. The only income which the **LEAGUE** has is from its short wave essentials. A pamphlet setting forth the **LEAGUE'S** numerous aspirations and purposes will be sent to anyone on receipt of a 3c stamp to cover postage.

FREE MEMBERSHIP CERTIFICATE

As soon as you are enrolled as a member, a beautiful certificate with the **LEAGUE'S** seal will be sent to you, providing the in stamps or coin is sent for mailing charges.

Members are entitled to preferential discounts when buying radio merchandise from numerous firms who have agreed to allow lower prices to all **SHORT WAVE LEAGUE** members.

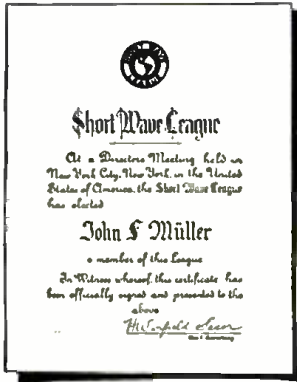

Illustration of engraved free membership certificate

SHORT WAVE ESSENTIALS LISTED HERE SOLD ONLY TO SHORT WAVE LEAGUE MEMBERS

They cannot be bought by anyone unless he has already enrolled as one of the members of the **SHORT WAVE LEAGUE** or signs the blank on this page (which automatically enrolls him as a member, always provided that he is a short wave experimenter, a short wave fan, radio engineer, radio student, etc.).

Inasmuch as the **LEAGUE** is international, it makes no difference whether you are a citizen of the United States or any other country. The **LEAGUE** is open to all.

Application for Membership SHORT WAVE LEAGUE

SHORT WAVE LEAGUE 2-35
99-101 Hudson Street, New York, N. Y.

I, the undersigned, herewith desire to apply for membership in the **SHORT WAVE LEAGUE**. In joining the **LEAGUE** I understand that I am not assessed for membership and that there are no dues and no fees of any kind. I pledge myself to abide by all the rules and regulations of the **SHORT WAVE LEAGUE**, which rules you are to send to me on receipt of this application.

I consider myself belonging to the following class (put an X in correct circle): Short Wave Experimenter Short Wave Fan Radio Engineer Student I own the following radio equipment:

Transmitting
Call Letters
Receiving
Name
Address
City and State
Country
I enclose 10c for postage and handling for my Membership Certificate.

SHORT WAVE LEAGUE LETTERHEADS

A beautiful letterhead has been designed for members' correspondence. It is the official letterhead for all members. The letterhead is invaluable when it becomes necessary to deal with the radio industry, mail order houses, radio manufacturers, and the like; as many houses have offered to give members who write on the **LEAGUE'S** letterhead a preferential discount. The letterhead is also absolutely essential when writing for verification to radio stations either here or abroad. It automatically gives you a professional standing.

A—SHORT WAVE LEAGUE letterheads, per 100..... **50c**

OFFICIAL SHORT WAVE LEAGUE LOG AND CALL MAGAZINE

Here is the finest book of its kind ever published. It contains the largest listing of short wave stations in the world, much larger in fact than the list published in **SHORT WAVE CRAFT** and other magazines. All experimental stations, no matter where located, are listed. A large section is provided where calls can be listed in a proper manner. This log section gives dial settings, time data, call letters, location, and other information. Another section has squared-paper pages on which you can fill in your own frequency curve for your particular receiver. It helps you to find stations which otherwise you could never log. It is the only book of its kind published.

B—Official Log and Call Magazine..... Prepaid **25c**

RADIO MAP OF THE WORLD AND STATION FINDER

The finest device of its kind published. The world's map on heavy board is divided into 23 sections, while the rotary disc shows you immediately the exact time in any foreign country. Invaluable in logging foreign stations. Also gives call letters assigned to all nations. Size 11" x 22".

C—Radio Map of the World and Station Finder..... Prepaid **25c**

GLOBE OF THE WORLD AND MAGNETIC COMPASS

This highly important essential is an ornament for every den or study. It is a globe, 6 in. in diameter, printed in fifteen colors, glazed in such a way that it can be washed. This globe helps you to intelligently log your foreign stations. Frame is of metal. Entire device substantially made, and will give an attractive appearance to every station, emphasizing the long-distance work of the operator.

D—Globe of the World..... Prepaid **\$1.25**

SHORT WAVE LEAGUE LAPEL BUTTON

This beautiful button is made in hard enamel in four colors, red, white, blue and gold. It measures three quarters of an inch in diameter. By wearing this button, other members will recognize you and it will give you a professional air. Made in bronze, gold filled, not plated. Must be seen to be appreciated.

E—SHORT WAVE LEAGUE lapel button..... Prepaid **35c**

EE—SHORT WAVE LEAGUE lapel button, like the one described above but in solid gold..... Prepaid **\$2.00**

SHORT WAVE LEAGUE SEALS

These seals or stickers are executed in three colors and measure 1 1/4 in. in diameter, and are gummed on one side. They are used by members to affix to stationery, letterheads, envelopes, postal cards and the like. The seal signifies that you are a member of the **SHORT WAVE LEAGUE**. Sold in 25 lots or multiples only.

G—SHORT WAVE LEAGUE seals..... per 25, Prepaid **15c**

SHORT WAVE MAP OF THE WORLD

This beautiful map, measuring 18x26 in. and printed in 18 colors is indispensable when hung in sight or placed "under the glass" on the table or wall of the short wave enthusiast. It contains a wealth of information such as distances to all parts of the world, political nature of the country in which a broadcast station is located, etc., and from the manner in which the map is blocked off gives the time in different parts of the world at a glance.

F—SHORT WAVE Map of the World..... Prepaid **25c**

PLEASE NOTE THAT ABOVE ESSENTIALS ARE SOLD ONLY TO MEMBERS OF THE LEAGUE—NOT TO NON-MEMBERS.

Send all orders for short wave essentials to **SHORT WAVE LEAGUE**, 99-101 Hudson Street, New York City.

If you do not wish to mutilate the magazine, you may copy either or both coupons on a sheet of paper.

SHORT WAVE LEAGUE 99-101 Hudson St., New York, N. Y.



G—15c for 25

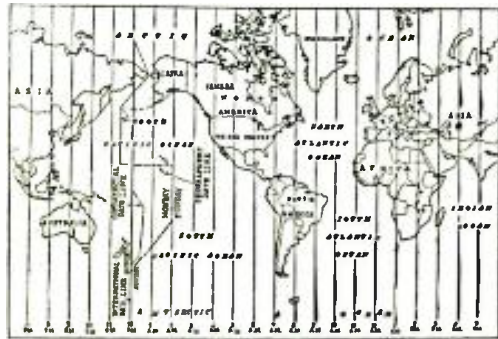

F—25c each



A—50c per 100

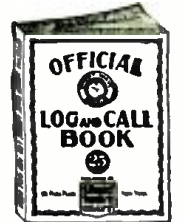

B—25c per copy

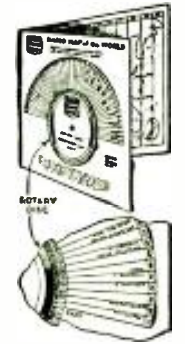

C—25c each



D—\$1.25 each



E—35c each

SHORT WAVE LEAGUE, 99-101 Hudson Street, New York, N. Y.

Gentlemen:
I am already an enrolled member in the **SHORT WAVE LEAGUE**
I am a new member and attach my application to this coupon
Please send me the following short wave essentials as listed in this advertisement:

for which I enclose \$ herewith.
(The **LEAGUE** accepts money order, cash or new U. S. Stamps in any denomination. Register cash and stamps.)

Name
Address
City and State
Country

2-35

Please mention **SHORT WAVE CRAFT** when writing advertisers

3 Tubes = 6 Super-Het

(Continued from page 635)

- 3—465 kc. I.F. transformers (Hammarlund)
- 3—10,000 ohm fixed resistors ½ watt (Aerovox)
- 3—100,000 ohm fixed resistors ½ watt (Aerovox)
- 1—100,000 ohm fixed resistor 1 watt (Aerovox)
- 1—50,000 ohm fixed resistor ½ watt (Aerovox)
- 2—500,000 ohm fixed resistors ½ watt (Aerovox)
- 3—1,000,000 ohm fixed resistors ½ watt (Aerovox)
- 1—20,000 ohm fixed resistor 1 watt (Aerovox)
- 1—400 ohm fixed resistor 1 watt (Aerovox)
- 1—300 ohm fixed resistor 1 watt (Aerovox)
- 1—500 ohm fixed resistor 1 watt (Aerovox)
- 1—1,500 ohm fixed resistor 1 watt (Aerovox)
- 12—.1 mf. fixed condensers (non inductive) 500 volt (Aerovox)
- 1—.01 mf. fixed condenser (non inductive) 500 volt (Aerovox)
- 1—.5 mf. fixed condenser (non inductive) 500 volt (Aerovox)
- 1—1. mf. fixed condenser (non inductive) 500 volt (Aerovox)
- 1—5. mf. fixed condenser (electrolytic 25 volt) (Aerovox)
- 1—.001 mf. fixed condenser mica (Aerovox)
- 3—.001 mf. fixed condensers mica (Aerovox)
- 1—7 prong small isolantite tube socket (National)
- 2—5 prong small isolantite tube sockets (National)
- 1—100,000 ohm potentiometer (Electrad)
- 2—7 prong (small) wafer tube sockets (National)
- 3—Type 58 tube shields (Hammarlund)
- 1—Headphone terminal strip (Insuline)
- 1—Antenna-Gnd. terminal strip (Insuline)
- 1—Ground Binding post (Insuline)
- 1—Vernier Tuning dial Type "B" (National)
- 1—6F7 tube RCA (Radiotron)
- 1—6A7 tube RCA (Radiotron)
- 1—6B7 tube RCA (Radiotron)
- 1—Metal chassis and front panel (Insuline)
- Chassis data—Front panel 11½"x7". Chassis 8½"x11"x1½".

Plug-In Coil Data (Na-Ald; Bud)

Meters Wave-length	Grid coil turns	Tickler turns	Distance between 2 coils
200-80	52 T. No. 28 En. Wound	19 T. No. 30 En. Close Wound (CW)	¾"
80-40	32 T. per inch 23 T. No. 28 En. Wound	11 T. No. 30 En. C. W.	¾"
40-20	16 T. per inch 11 T. No. 28 En. 3-32" between turns C. W.	9 T. No. 30 En. C. W.	¾"
20-10	5 T. No. 28 En. 3-16" between turns	7 T. No. 30 En. C. W.	¾"

Coil form—2¼" long by 1¼" dia. 5 pin base.
(See article for alterations to oscillator coils.)

Wanted - Automatic Regeneration!

● Today there is one outstanding and important problem which short-wave experimenters should strive to solve—that is, *automatic regeneration control*. SHORT WAVE CRAFT Magazine will be very glad to hear from experimenters everywhere who have devised a circuit or circuits which automatically (or nearly so) varies the regeneration as the different wavelengths are tuned in. Tomorrow some genius is going to show the short-wave fraternity how to do this, and quite possibly it will comprise some simple arrangement, whereby the variable resistance or capacity used to change the degree of regeneration is varied *simultaneously* with the tuning, such as by combining or joining the mechanical controls by cams or levers on the receiver.

Another way of attacking the problem is in a pure electrical manner, whereby the impedance of a circuit is caused to vary automatically as the degree of regeneration increases and vice versa. Possibly by the use of suitable chokes, resistors, and

CLASSIFIED

Advertisements are inserted at 5c per word to strictly amateurs, or 10c a word to manufacturers or dealers. Each word in a name and address is counted. Cash should accompany all orders. Copy for the March issue should reach us not later than January 5th

ACCESSORIES	OHM'S LAW CALCULATOR	SHORT WAVE RECEIVERS
<p>GENERAL ELECTRIC BATTERY operated dynamotors 21/750 volt \$25. (On 12 delivers 375) 500 cycle 500 watt alternators \$7.50 List. Henry Kienzle, 501 East 84th Street, New York.</p> <p>"HAM" OFFERS & WANTS</p> <p>\$100.00 RCA SUPERHET. BATTERY type, "bull-in" hoop, speaker, etc. Barkan \$35.00; VioGreen 8-tube battery superhet, Weston meter, \$8.00; MB29 National Tuner with four 8.G. and detector tube, \$15.00; 45 push-pull Thordarson Power-Pack, with 27 first A.F. (with Tubes), \$15.00; "High Fidelity" 6 ft. Victor orthophonic (exponential) Horn, speaker unit, tone arm; also "magnetic" pick-up, \$15.00; RCA 210 power-pack with Rectifier (originally \$70.00), \$8.00. Harry Arkeron, Box 322, Ramsey, N.J.</p> <p>ELECTRIC DOORLE SHORT WAVE Receiver. Wired and tested to receive Australia. Complete with coil and tubes. \$7.25. Stanley Balkowick, 12 Marble Terrace, Hastings, New York.</p> <p>COMET P100 AVC, XTAL; Wright DeCoster Dynamic Speaker, 15 to 550 Meter Calls. Complete \$80.00. J. D. Avery, 40-25 196th St., Flushing, L.I., N.Y.</p> <p>SWAP ELEN ELECTRIC THREE Receiver. Complete for 100 Volt, 150 milliamperes, power pack. Hays Pool, Oia, Ark.</p> <p>TUBE A.C. "HAM" RECEIVER. Complete \$10. Edwin Klouda, Route 2, Cedar Rapids, Iowa.</p> <p>FOR SALE—MODEL 710 READ-rite Analyzer. Harry Bannetstberger, Spooner, Wis.</p> <p>FOR SALE OR TRADE SCOTT all-wave receiver, \$50. Box 578, Ontario, Ore.</p>	<p>Lightning Slide Rule; solves all problems of Voltage, Current and Resistance. Power, Wire Sizes, etc. Range: 1 micro-amp. to 1000 amps.; 1 micro-volt to 10,000 volts; 1 micro-ohm to 10 megohms; 1 micro-watt to 10 megawatt; wire sizes 0 to 36 B. & S. gauge. Introductory price \$1.00 (refund). The Dataprint Co., Box 322, Ramsey, N.J.</p> <p>TEN PRACTICAL AND INEXPENSIVE changes converting Dodge 12-V. Ford T.A., Chevrolet Delco 6-V generators, into 100-500 watt capacity A.C. generators, or into 22-110 volt D.C. motor or generator. Dodge is 500-W. self-excited. All in one book illustrated with complete simplified instructions and drawings for only \$1. AUTOPOWER, 411 S. Hoyle Ave., Chicago.</p> <p>AGENTS WANTED FOR STOP-page Compass—Cost U.S. Government \$30.00. Ideal for Radio Experimental Laboratory. Italy, jeweled, solid bronze, 4 inches square in hardwood case, sells for \$1.50. Agent's price \$2.50. Gold Shield Products Co., 98 Park Place, Dept. C., New York City.</p> <p>SENSATIONAL AIR CONDITION-er. Looks like a radio. Sells on sight. Sample sent for \$4.95. A. L. Diamond, 98 Park Place, New York.</p>	<p>50% DISCOUNT ON OUR FAM-ous Line of Custom Built Short Wave Receivers, World Wide Reception Guaranteed. Latest Models. We make a complete line of equipment. Transmitters, Monitors, etc. We construct to order any receiver or transmitter. Stamp for Prices. Ensil Radio Laboratory, 1527 Grandview Street, S.E., Warren, Ohio.</p> <p>IN STOCK—SHIPPED PREPAID: Patteron Pr-12s \$82; Silver World Wide Nines \$79.97; Silver 5Cs \$74.70. All other receivers, Collins transmitters, apparatus. Trade-in your receiver. Code machines rented. Write. Henry Radio Shop, Butler, Mo.</p> <p>BLUEPRINT DATA IS CRYSTAL Sets—Tubes—4; 1850 Mile; Selective; Speaker, 25c (Coin). Setbuilders List Free. Modern Radiolabs, 151-A Liberty, San Francisco.</p> <p>FOR SALE: NEW AND USED Shortwave Receivers. Sets of all types, Hammarlund—Nationals—Scotts—Patteron, etc. Edward Schwarz, Dumont, N.J.</p> <p>WORLD WIDE ALL-WAVE Radios—3 models. Hal. or Electric. World's cheapest. No-odd sample. 20th Century Co., R-2233, K.C., Mo.</p>
<p>QSL-CARDS-SWL</p> <p>QSLs, SWLs, SPECIAL 200—\$1.00. Speedy Service. New equipment. W8E8N—1827 Cone, Toledo, Ohio.</p> <p>QSL CARDS. NEAT, ATTRAC-tive, reasonably priced, samples free. Miller, Printer, Ambler, Pa.</p> <p>QSLs, SWLs, 75c a 100 2 COLORS post paid W8DGH 1816 5 Ave. N., Minneapolis, Minn.</p> <p>QSL's—SWL's—FREE SAMPLES. WIAZF, 83 Orange St., Rosindale, Mass.</p>	<p>SHORT WAVE COMPONENTS</p> <p>NEW, SUPERSENSITIVE, TUN-able, Police and Amateur Call Short-wave Attachments. Work with Any Set. Builds Shortwave volume. Mention Type of Set. Price, \$1.10, Postpaid. Delft, Fairbanks, Oakland, California.</p> <p>USED PARTS FOR SHORTWAVE Sets. Instructions included. Two-tube, complete, \$2.50. Three-tube, complete, \$3.50. Tubes, .70 each extra. All-ShortWave, Fairbanks, Oakland, California.</p> <p>4-LO-LOSS COILS, SMALL FORMS, four colors 15-200 meters, 50. List on request. Short Wave Accessories, 121 Derby Street, Valley Stream, New York.</p> <p>PLUG-IN COILS, WOUND ON tube bases .30 per set. Regular forms .50. Six prong .75. Noel, 809 Alder, Scranton, Pa.</p> <p>SELL USED BROADCAST AND short wave equipment. Write for list. White Italgio Laboratory, Sandpoint, Idaho.</p>	<p>TELEVISION</p> <p>TELEVISOR COMPLETE \$10.00. Arthur Pohl, 2131 Palms Ave., Detroit, Mich.</p> <p>TRANSCIVERS</p> <p>TRANS-CEIVERS \$3.95! SOME-thing new; no switches. Complete. Less accessories. See Page 566 of January S.W.C., or page 502 of the December issue. For more detailed information write us inclosing a 3c stamp. Write now. The Burks Radio Company, 1443 W. Decatur St., Decatur, Illinois.</p> <p>TRANSMITTING EQUIPMENT</p> <p>DO YOU HAVE A PERSONAL Idea you wish in a Short Wave Receiver or Transmitter? Let us design or construct it for you. Ensil Radio Laboratory, 1527 Grandview Street, S.E., Warren, Ohio.</p> <p>\$4.95 — 25W TRANSMITTERS.—Radio Service Laboratories, Fort Wayne, Indiana.</p>

YOU DON'T

READ AND THEN DISCARD
SHORT WAVE CRAFT

Readers keep their copies for years as a steady reference and thousands of letters attest to this. It is now possible to *save your copies* and for this purpose we designed a splendid binder for you which holds twelve copies. It is made of *heavy substantial material* and is covered with black grain leatherette. The name of the magazine is stamped in gold on the cover.

An ingenious mechanical arrangement is provided which makes it possible to *hold the copies flat when reading from the binder*.

SHORT WAVE CRAFT Binder as described, \$1.25
prepaid in the United States.

Canada and foreign countries 25c extra. We accept money order, check, stamps or cash.

SHORT WAVE CRAFT
99-101 HUDSON STREET NEW YORK, N. Y.

fixed condensers in a network, inserted in the plate or shield grid circuit of the detector tube circuit, the problem can be solved.

Another hint for the experimenter might lie in the direction of causing the detector tube to control the grid of the R.F. tube, similar to the action of our present automatic volume controls. In any event, if you have devised a circuit or device which seems to realize the solution of the above problem, the editor shall be glad to hear from you in regard to publishing an article on it.

Please mention SHORT WAVE CRAFT when writing advertisers

DOERLE *Globe Girdling* Official Receivers SHORT-WAVE 1935 MODELS

WE Guarantee RECEPTION with the **5-TUBE** DOERLE
of Foreign Speech and Music the **De Luxe**
A. C. Short-Wave RADIO



15-550 Meters • 12,500 Mile Range •
Airplane Dial • Dynamic Speaker •
• 8 - Low Loss Ribbed Plug-in Coils
\$25⁹⁵

Chassis, speaker, tubes,
8 coils, Cabinet.
Nothing Else to Buy

**Will Outperform Many 10-Tube
Expensive Receivers**

A powerful 5-tube "rig" complete with its self-contained hum-free power pack and dynamic speaker; all mounted on a single chassis and contained in a large handsomely finished black crackle cabinet with patterned screen on top.

LOOK AT THIS DX-QSL LIST!

During its initial test, in one sitting, this receiver pulled in on its loud speaker, at good room volume, the following variable log: W1XAL, W1XAZ, Boston; W3XAL, Boundbrook, N.J.; W3ZAL, Cincinnati; W3XAA and W3XF, Chicago; GSC, GSD, GSE, GSF, Daventry, England; DJA, DJB, DJC, DJD, Zeelen, Germany; HBL, HBP, Geneva; VE9GW, Dorval, Y9DN, Quebec; GE9DR, Montreal; VE9HX, Halifax; XETE, Mexico City; YU1BC, YV3BC, Caracas; CP5 Bolivia; LSN, Buenos Aires; CDC, Havana; EAQ, Madrid; WQO and WEF, testing with the Byrd Expedition and a whole flock of amateurs in practically every radio district of the United States. After that, we could no longer keep our eyes open so we "signed off" to bed. Uses a simple regenerative circuit—so simple as to be entirely fool-proof. Tubes: 1—6D6, 1—6E7 (actually two tubes in one), 1—3Z5, 1—41 power output tube and 1—81 full-wave rectifier. Two gang tuning condenser; single dial control; FULL-VISION ILLUMINATED AIRPLANE DIAL. Shp. wt. 35 lbs.

No. 5000. "DOERLE AC-5" Short Wave Receiver. Complete with Tubes, Speaker and 8 coils covering 15 to 200 meters. Completely wired and tested. (NOT SOLD IN KIT FORM) **YOUR PRICE, \$25.95**

No. 5002. "DOERLE DC 5" SHORT-WAVE RECEIVER WITH SELF-CONTAINED POWER SUPPLY AND DYNAMIC SPEAKER. Same circuit as the "Doerle AC 5." Uses 1—6D6; 1—6E7; 1—3Z5; and 2—41's in parallel. Completely wired and tested. Shp. wt. 30 lbs. **YOUR PRICE, \$23.95**

FREE 5 DAY TRIAL

You can now purchase this Doerle Deluxe 5-tube Short Wave Radio on a 5-day trial basis. If not convenient to pay all cash, send a deposit and pay the balance C.O.D. Prove to your own satisfaction that it will give you World Wide reception, and that our guarantee means exactly what it says. If on or before five days after receiving the radio you are not perfectly satisfied, write us; shipping instructions. Upon receipt of the merchandise we will refund your purchase price in full.

DOERLE 3-TUBE MODELS
A.C. - 2 Volts and D.C. 15 to 200 Meters
\$12.45
LESS TUBES

4-TUBE PERFORMANCE

If you are a Doerle fan, you will remember the tremendous popularity of the 1934 3-tube Doerle receivers. The 1935 instruments, however, are far superior in that they incorporate the latest developments in short-wave radio. Two-gang tuning condenser, single dial control, FULL-VISION ILLUMINATED AIRPLANE DIAL, two sets of plug-in coils (4 coils per set), loud speaker operation on many foreign stations. Only parts of first grade value are employed.

3-TUBE A.C. MODEL uses 1—6E7 (two tubes in one), 1—6D6 and 1—41 power output tube. Used with batteries OR A.C. power pack (listed below).

The 3-tube DC model uses the same tubes and has a built-in power supply so that it may be plugged in directly across the 110 volt DC line.

The 3-tube battery model employs a 34 variable-mu RF pentode, a 30 regenerative detector and a twin triode type 19 (actually 2 tubes in one) as two stages of AF amplification. Shp. wt. of all models 15 lbs.

- ALL MODELS ON SAME CHASSIS**
- No. 5004K. "Doerle AC-3" Receiver Kit including Coils, Cabinet and Diagram, less tubes. **YOUR PRICE, \$14.45**
 - No. 5005K. "Doerle DC-3" Short-Wave Receiver Kit, including coils, cabinet and diagram. **Less \$12.45** tubes. **YOUR PRICE, \$12.45**
 - No. 5006K. Doerle 3-Tube 2-Volt Battery, Short-Wave Receiver Kit, less tubes but including cabinet, coils and diagram. **\$12.45** **YOUR PRICE, \$12.45**
 - Complete set of RCA Licensed Tubes for 3-Tube AC or DC or 2-Volt model. **YOUR PRICE, \$2.70**
 - No. 2149. AC Hum-Free Power Pack **YOUR PRICE, (wired), including \$5.50** tube.
- Wired & Tested \$1.50 extra.

DOERLE GLOBE-GIRDLING Receivers

Important Notice WE ORIGINALLY brought out the now justly famous DOERLE short wave receivers in 1932. Since that time, we have always followed the policy of making these receivers just as good as it was humanly possible to do irrespective of price. In our Grade A receivers, we have steadily maintained the "quality first" policy. We, however, realized that many wished to get lower priced sets, and we are now offering such a popular priced line to our many friends and followers.

This new line still uses excellent materials, although we use somewhat lighter chassis, and in other respects we have effected considerable savings which are now passed on to you. Even at these low prices, however, we could not afford the risk of cheapening the main parts. We are using HAMMARLUND TUNING CONDENSERS, and other equally well-known components. The sets we offer here are not quite as rugged as our standard DOERLE sets on which we never skimp, but if you are looking for low-priced sets, receivers that will do the work and do it well, here are the sets for you.

This new line of DOERLE receivers may be likened to low-priced automobiles as compared with the more luxurious and expensive ones. Both types will get you to the same places, yet one will outlast the other and will be easier to handle. Our usual guarantee goes with these lower-priced sets, the same as with our higher-priced ones. You will make no mistake in getting any one of these sets. These "Globe Girdling" DOERLE sets are guaranteed to bring in short-wave broadcast stations from all over the world and you will get music and every kind of entertainment from all 5 continents.

The excellent performance of these 2-Tube Doerle receivers has already become traditional. Mass production of chassis, the use of good "over-flow" parts from manufacturers and tube-base plug-in coils, make it possible for us to sell these competitive receivers at the **LOWEST PRICES ON THE MARKET.**

- NO. F-349 2-VOLT BATTERY MODEL DOERLE KIT—This receiver uses 2 of the new economical 30 tubes. Batteries required are 2 No. 6 dry cells (or a 2 volt storage cell) and 2 45 volt "B" batteries. Sold complete with instructions and diagram. Shipping weight 5 lbs. **YOUR PRICE, Less Tubes, \$14.45**
- Pair of Matched 30 Tubes.....\$1.50
- NO. F350 ALL-ELECTRIC-A.C.-D.C. DOERLE KIT—This model requires no battery or power pack at all. It works anywhere and on any type of current at 110 volts. Has a self-contained power supply. Uses 2 type 37 tubes and 1—78. Shipping weight 8 lbs. **YOUR PRICE, Less Tubes, \$5.95**
- Three Matched Tubes.....\$2.30

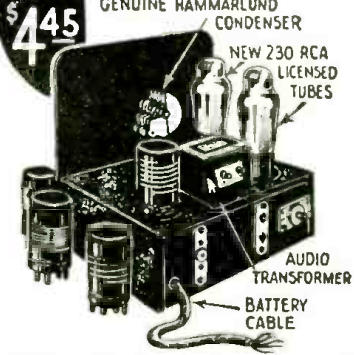

GENUINE HAMMARLUND CONDENSER
NEW 230 RCA LICENSED TUBES
AUDIO TRANSFORMER
BATTERY CABLE

- NO. F351 STRAIGHT A.C. DOERLE KIT—This model uses either 2 50's or 2 27's. It may be used in conjunction with our own power pack. Listed below. The set may also be run on a 24-volt filament transformer or a "B" eliminator or, instead of the "B" eliminator, 2 45-volt "B" batteries. Shipping weight 6 lbs. **YOUR PRICE, Less Tubes, \$4.45**
- Pair of Matched 50 or 27 Tubes.....\$1.30
- NO. F352 COMPETITIVE A.C. POWER PACK KIT—A constant power unit delivering 2 1/2 volts at 5 amps for filament supply and 250 volts D.C. at 50 ma for plate supply. Requires a type 80 rectifier. **YOUR PRICE, Less Tube, \$4.70**
- Rectifier Tube.....\$.40

FREE! CATALOGS

See our ads on pages 618 and 630

WE WILL WIRE AND TEST ANY OF THESE KITS WHEN ORDERED FOR \$1.25
Send money order or certified check. C.O.D. only when 20% remittance accompanies order.

RADIO TRADING CO., 101-A HUDSON ST., NEW YORK CITY

Please mention SHORT WAVE CRAFT when writing advertisers

● Index to Advertisers ●

A	
Ace Radio Laboratories.....	631
Aerovox Corporation.....	613
Alden Products Co.....	622
Allied Engineering Institute.....	630
Allied Radio Corporation.....	Inside Front Cover
American Radio Hardware Co., Inc.....	639
Amperite Corporation.....	618
Amplivox Laboratories.....	617
Anker Labs.....	631, 639
Arco Tube Company.....	624
B	
Blan, the Radio Man, Inc.....	635
Bud Radio Inc.....	616
Burstein-Appleebe Co.....	619
C	
Candler System Co.....	619
Centralion Engineering Co.....	626
Classified Advertisements.....	637
Coast-to-Coast Radio Corp.....	615
Coyne Electrical School.....	579
D	
Dataprint Company.....	631, 633
Dodge's Institute.....	630
E	
Eagle Radio Co.....	618
Eilen Radio Laboratories.....	625
Electrad, Inc.....	623
Everyday Science & Mechanics.....	635
Experimental Radio Labs.....	624
F	
First National Television, Inc.....	631
G	
Goldentone Radio Company.....	635
Gold Shield Products Co.....	615, 633, 635
Gross Radio, Inc.....	615
H	
Hammarlund Manufacturing Co.....	617
Harrison Radio Company.....	613
I	
Instructograph Company.....	639
Insuline Corp. of America.....	627
International Correspondence Schools.....	629
K	
Korrol Mfg. Co., Inc.....	628
L	
Lancaster, Allwine & Rommel.....	630
Leotone Radio Co.....	626
L. I. Marine & Electric Co.....	633
Lynch, Arthur H., Inc.....	633
Lynch Manufacturing Co., Inc.....	Inside Back Cover
M	
McElroy, T. R.....	615
McGraw-Hill Book Company, Inc.....	624
Midwest Radio Corp.....	Back Cover
N	
National Company, Inc.....	621
National Radio Institute.....	577
New York YMCA Schools.....	624
P	
Popular Medicine.....	633
Postal Radio Corp.....	614
Prompt Radio Service Co.....	635
R	
Radiobar Company of America.....	614
Radio City Labs.....	628
Radio Craft.....	630
Radio Publications.....	634
Radio Technological College.....	626
Radio Trading Co.....	618, 630, 632, 638
RCA Institutes, Inc.....	628
RCA Victor Co.....	635
Remington-Rand, Inc.....	622
S	
Sargent, E. M., Co.....	619
Sexology Magazine.....	630
Short Wave Coil Book.....	628
Short Wave League.....	618, 619, 636
Short Wave Listener.....	629
Sterling Casualty Insurance Co.....	622
Supertone Products Corp.....	617
T	
Teleplex Co.....	613
Thor Radio Co.....	635
Trimm Radio Mfg. Co.....	619
U	
Uncle Dave's Radio Shack.....	630
V	
Vibroplex Co., Inc.....	630
W	
Wellworth Trading Company.....	626
Wholesale Radio Service Co., Inc.....	616
World Trotter Radio Labs.....	628, 633

(While every precaution is taken to insure accuracy, we cannot guarantee against the possibility of an occasional change or omission in the preparation of this index.)

Economy-3 Battery Set

(Continued from page 589)

to follow the layout as closely as possible. By all means do not change the relation of the tubes and coils to one another or feedback and instability will be the result. Make all leads as short as possible and make sure that the connections are just as firm as you can make them. In tuning up the receiver, set the R.F. trimmer to about half capacity and then adjust the small "padding" condensers in the top of the coils so that the two stages are in resonance; this can be readily determined by an increase in "background" noise, even though no station is tuned in. Then tune across the dial and determine if the padding condensers have been adjusted to place the band, for which the coils were intended, in the center of the dial; if not, further adjustment of the "padding" condensers in the coils is necessary. When adjusting these condensers always make sure that the 50 mmf. trimmer on the panel is set to one-half capacity. Use a good antenna and ground and you will be thrilled with the results this little set will give.

Parts List for the "Economy 3"

- 1-2 kang, 140 mmf. condenser (C2); Hammarlund.
- 1-50 mmf. midret "air tuned padding" condenser; Hammarlund.
- 5-.01 mf. by-pass condensers, Aerovox.
- 1-35 mmf. midret padding condenser (C3), compression type; Hammarlund.
- 1-.0001 mf. mica condenser, Aerovox.
- 2-.00025 mf. mica condensers, Aerovox.
- 1-.25 mf. by-pass condenser, Aerovox.
- 1-.25 mf. by-pass condenser, Aerovox.
- 1-300 ohm. half-watt resistor, Aerovox.
- 1-3 meg. half-watt resistor, Aerovox.
- 1-1/2 meg. half-watt resistor, Aerovox.
- 1-1/2 meg. half-watt resistor, Aerovox.
- 1-2000 ohm. half-watt resistor, Aerovox.
- 1-50,000 ohm potentiometer, Electrad (with switch).
- 2-sets 15-200 meter plug-in coils, "band-spread" or "full coverage" (see text), Na-Ald. (Bud: I.C.A.).
- 1-2.5 mf. R.F. choke, Hammarlund.
- 5-5 prong wafer sockets, Na-Ald.
- 1-phone terminal strip, Na-Ald.
- 1-antenna ground terminal strip, Na-Ald.
- 1-6 wire battery cable, Na-Ald.
- 1-piece of 1/8 inch aluminum, 4 1/2"x4 1/2" for shield, Blan.
- 2-tube shields.
- 1-drilled cabinet and chassis, see text (sprayed black cracked enamel), Supertone.
- 1-2 1/2 inch airplane type dial.
- 3-Knobs.
- 3-Sylvania type 15 R.F. pentodes.
- 3-45 volt B-batteries, Burkess.
- 4-No. 6 dry cells, Burkess.
- 1-pair phones, 2,000 or 5,000 ohms (5000 ohms most sensitive), Trimm.

Free! Short-Wave Dial "Log!"

● Here's your chance to obtain free, a short-wave station "log" of the circular type, designed by one of the famous Crosley radio engineers, on the same principle as the circular slide rule. By simply rotating the arm on this circular "log," the call letters of the desired station, or frequency in kilocycles, is visible through the window in the arm. The location of the station, the hours of the day over which the broadcast takes place, and also the days of the week the station broadcasts, are "simultaneously" indicated.

This remarkable short-wave broadcast station "log" gives you instantly all of the above mentioned data on the principal short-wave stations in thirty-four countries. The outer circle of the circular "log" gives the kilocycles of the different stations; the next circle gives the call letters, and in the center, are the cities and countries in which the stations are located. The hours of the broadcast and the days of the week appear on the arm, and by a clever method of calibrating the dial, the day and hours of the broadcast of any given station is at once indicated. On the reverse side of the dial "log," the thirty-four countries are listed and the kc. given; it is only necessary, therefore, to turn the rotating arm to the number of kc. listed in the outer circle of the log and all the other information regarding that particular station is immediately indicated.

Simply send your name and address and ask for S. W. Dial Log No. 504 to:
Service Department, SHORT WAVE CRAFT,
99-101 Hudson Street, New York City

ANKER-CORSAIR
A.C.-D.C. SHORT-WAVE SET

\$5.95



● The "Corsair" incorporates the following features hitherto unheard of in a one tube receiver sold at any price.

- 110-120 V. AC-DC built-in power supply (can also be used on 220 V. or battery).
- Compactness and lightness of weight.
- 16 to 1 and 40 to 1 halving vernier tuning (2 speeds) with 270 degree spread.
- 15 to 200 meter coverage with four coils, broadcast coil at slight additional cost.
- Completely enclosed and shielded by hinged cover, black wrinkle finished metal cabinet.

The "BUCCANEER" S. W. RECEIVER \$4.95



Notices or experienced amateurs will find the "Buccaneer" a constant source of pleasure through its consistently excellent performance.

FEATURES

- Uses economical 34-33 tubes.
- Clear, loud reception.
- Smooth tuning.
- First grade material.
- Cadmium plated chassis and cracked panel.
- Lo-signal to noise ratio.
- 14 to 200 meter coverage.

Kit complete, less tubes.....	Net Price
Wiring.....	\$4.95
Tubes.....	1.50
Broadcast coil.....	1.74
Anchor-lite single phone.....	.45
	.75

"BUCCANEER" Junior Appearance and construction identical to the "Buccaneer," except that it uses a single 30 tube. Net Price \$2.95

Kit of parts.....	Net Price
Broadcast coil.....	\$2.95
Wiring.....	.45
	1.20

Our Free Catalog sent on request
ANKER LABS
20 W. 22nd St., Dept. S-2-35, New York City

Start to Send and Read RADIO CODE at Once! Practice at Home with

Instructograph Code Teacher

CODE STUDENTS everywhere are turning to instructograph, because there is no better way to get regular, systematic practice which is necessary to thoroughly master radio code. No talent or experience necessary. . . . Simple as A.B.C. . . . All you have to do is "listen" and imitate. . . . Instructograph provides code practice and Book of Instructions explaining how to practice just like an Instructor would do. . . . Failure impossible.



Terms as Low as \$2 Per Month

Made more progress in two months with Instructograph than in six months in school writes one student. . . . What others are doing you can do with Instructograph. Machines, Tapes and Book of Instructions for sale or rent. . . . Terms as low as \$2 per month. . . . Rent for a month. . . . If you do not agree that Instructograph is the quickest and easiest way to learn code, return it. . . . Rental applied on purchase price if desired. . . . Send to-day for particulars. . . . No obligation.

INSTRUCTOGRAPH COMPANY Dept. SW-14
912 Lakeside Place Chicago, Ill.

2 1/2 AND 5 METER TELESCOPE ANTENNAS



Doublet type works on 2 1/2 and 5 meters. Completely installed. From 4 ft. to 9 ft. telescopic.
Price . . . \$5.00

Straight type works on 2 1/2 and 5 meters. Collapsible 36 inches. Telescoped 9 ft. 1/2 Wave Type.
Price . . . \$3.00

Shipped Prepaid
The Doublet type can be used either HORIZONTALLY or VERTICALLY. Can be telescoped for the 2 1/2 or 5 Meter band. Constructed on new telescopic principle. The ham's ideal.
Special Telescopic Antennas Made to Order
Write for catalog and circular.
AMERICAN RADIO HARDWARE COMPANY, INC.
Dept. SW 135 Grand Street New York, N. Y.

The 4 ESSENTIAL SHORT WAVE BOOKS

'ROUND THE WORLD FANS USE THESE GREAT SHORT WAVE BOOKS

These great books contain everything on short waves that is really worth knowing—they are books which have been most enthusiastically welcomed by short-wave fans. The cost of the books is extremely low in comparison with the valuable material which they contain.

There is not a short-wave fan, experimenter or interested radio-minded reader who will not want these books. Right up-to-the-minute with new material on outstanding developments in the short wave field. The books are authoritative, completely illustrated and not too highly technical.

Ten Most Popular Short Wave Receivers. How to Make and Work Them

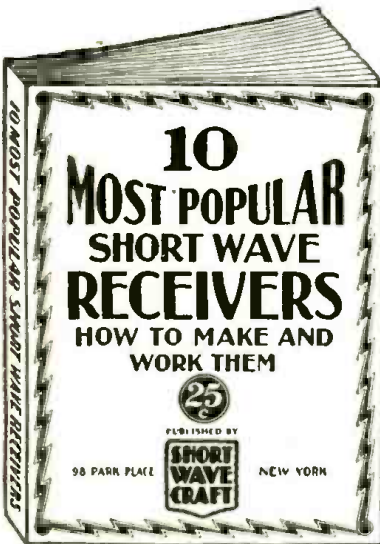

This new volume is a revelation to those who wish to build their own short wave receivers. The editors of SHORT WAVE CRAFT have selected ten outstanding short wave receivers and these are described in the new volume. Each receiver is fully illustrated with a complete pictorial representation, photographs of the set complete, hookup and all worthwhile specifications. Everything from the simplest one tube set to a 5-tube T. R. F. receiver is presented. Complete lists of parts are given to make each set complete. You are shown how to operate the receiver to its maximum efficiency.

CONTENTS

The Doerle 2-Tube Receiver That Reaches the 12,500 Mmc Mark, by Walter C. Doerle.
 2-H.F. Pentode S-W Receiver having two stages of Tuned Radio Frequency, by Clifford E. Denton and H. W. Seer.
 My de Luxe S-W Receiver, by Edward G. Ingram.
 The Binneweg 2-Tube 12,000 Mile DX Receiver, by A. Binneweg, Jr.
 Build a Short Wave Receiver in your "Brief-Case," by Hugo Gernsback and Clifford E. Denton.
 The Denton 2-Tube All-Wave Receiver, by Clifford E. Denton.
 The Denton "Stand-By," by Clifford E. Denton.
 The "Stand-By" Electrified, "The Short-Wave MEGADYNE, by Hugo Gernsback.
 A COAT-POCKET Short Wave Receiver, by Hugo Gernsback and Clifford E. Denton.
 Boy, Do They Roll In on This One Tuber, by C. E. Denton.
 The S-W PENTODE 4, by H. G. Cisin M. E.
 Louis Martin's Idea of A GOOD S-W RECEIVER, by Louis Martin.

25c

40 PAGES
 OVER 75 ILLUSTRATIONS
 IMPORTANT
 THERE IS NO DUPLICATION BETWEEN THIS BOOK AND OUR OTHER VOLUMES—"HOW TO BUILD AND OPERATE SHORT WAVE RECEIVERS." ALL THE MATERIAL PUBLISHED IN THE NEW BOOK HAS NEVER APPEARED IN ANY BOOK BEFORE.

The Short Wave Beginner's Book

Here is a book that will solve your short wave problems—leading you in easy stages from the simplest fundamentals to the present state of the art as it is known today. It is the only low-priced reference book on short waves for the beginner.

The book is profusely illustrated with all sorts of photos, explanations and everything worth while knowing about short waves—the book is not "technical." It has no mathematics, no "high-faluting" language and no technical jargon. You are shown how to interest a distributor and a few simple sets are also given to show you how to go about it in making them.

It abounds with many illustrations, photographs, simple charts, hookups, etc., all in simple language. It also gives you a tremendous amount of very important information which you usually do not find in other books, such as time conversion tables, all about aerials, noise elimination, how to get verification cards from foreign stations, all about radio tubes, data on coil winding and dozens of other subjects.

Partial List of Contents

Getting Started in Short Waves—the fundamentals of electricity. Symbols, the Short Hand of Radio—how to read schematic diagrams. Short Wave Cords—various types and kinks in making them. Short Wave Aerials—the points that determine a good aerial from an inefficient one. The Transposed Lead-In for reducing Man Made Noise. The Beginner's Short-Wave Receiver—a simple one tube set that anyone can build. The Beginner's Six-Gets-on-amplifier—how the volume may be increased by adding an amplifier. How to Tune the Short-Wave Set—telling the important points to get good results. Regeneration Control in Short Wave Receivers. Audio Amplifiers for S. W. Receivers. How to Couple the Speaker to the set. Learning the code—for greater enjoyment with the S-W set. Wave Length to Frequency Chart. Wire Chart—to assist in the construction of coils. Kinks in the construction of S-W Receivers.

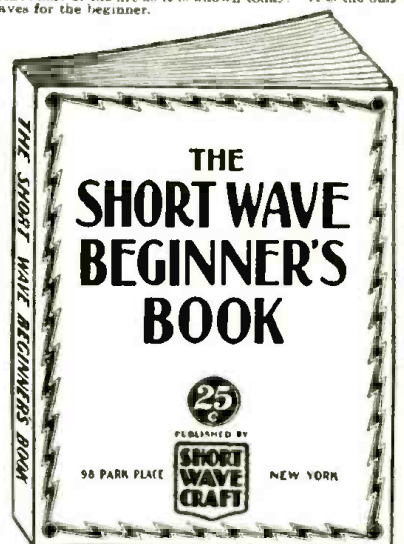

40 PAGES
 OVER 75 ILLUSTRATIONS
 25c

How to Build and Operate Short Wave Receivers

is the best and most up-to-date book on the subject. It is edited and prepared by the editors of SHORT WAVE CRAFT, and contains a wealth of material on the building and operation, not only of typical short-wave receivers, but short-wave converters as well. Dozens of short-wave sets are found in this book, which contains hundreds of illustrations; actual photographs of sets built, hookups and diagrams galore.

The book comes with a heavy colored cover, and is printed throughout on first-class paper. No expense has been spared to make this the outstanding volume of its kind. The book measures 7½x10 inches.

This book is sold only at such a ridiculously low price because it is our aim to put this valuable work into the hands of every short-wave enthusiast.

We know that if you are at all interested in short waves you will not wish to do without this book. It is a most important and timely radio publication.

Over 150 Illustrations
 72 Pages 7x10 Inches

50c

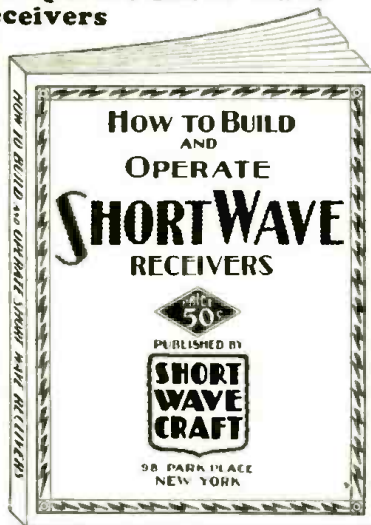

How to Become an Amateur Radio Operator

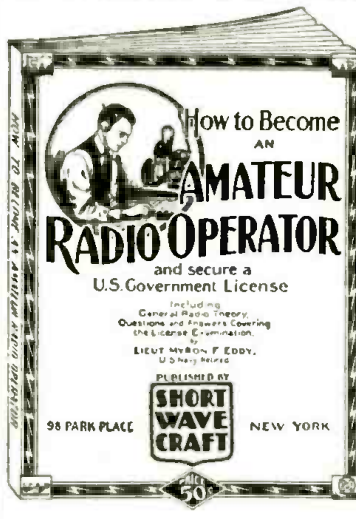

We chose Lieut. Myron F. Eddy to write this book because his long years of experience in the amateur field have made him pre-eminent in this line. For many years he was instructor of radio telegraphy at the I.R.C.A. Institute. He is a member of the I.R.E. (Institute of Radio Engineers), also the Veteran Wireless Operators' Association.

If you intend to become a licensed code operator, if you wish to take up phone work eventually, if you wish to prepare yourself for this important subject—this is the book you must get.

Partial List of Contents

Ways of learning the code. A system of sending and receiving with necessary drill words is supplied so that you may work with approved methods. Concise, authoritative definitions of radio terms, units and laws, brief descriptions of commonly used pieces of radio equipment. This chapter gives the working terminology of the radio operator. Graphic symbols are used to indicate the various parts of radio circuits. General radio theory particularly as it applies to the beginner. The electron theory is briefly given, then waves—their creation, propagation and reception. Fundamental laws of electric circuits, particularly those used in radio are explained next and typical basic circuits are analyzed. Descriptions of modern receivers that are being used with success by amateurs. You are told how to build and upgrade these sets. Amateur transmitters. Diagrams with specifications are furnished so construction is made easy. Power equipment that may be used with transmitters and receivers, rectifiers, filters, batteries, etc. Regulations that apply to amateur operators. Appendix which contains the International "Q" signals, conversion tables for reference purposes, etc.

Over 150 Illustrations
 72 Pages 7x10 Inches

50c

All the books shown on this page are published exclusively by

SHORT WAVE CRAFT

99-101 Hudson Street, New York, N. Y.

CLIP-MAIL

SHORT WAVE CRAFT
 99-101 Hudson Street, New York, N. Y.

SW-2-35

Gentlemen: I enclose herewith my remittance for the amount of \$..... for which you are to send me, postpaid, the books checked below.

- () Ten Most Popular Short Wave Receivers. How to Make and Work Them... 25c each
- () The Short Wave Beginner's Book... 25c each
- () How to Build and Operate Short Wave Receivers... 50c each
- () How to Become an Amateur Radio Operator... 50c each

Name.....
 Address.....
 City..... State.....

(Send remittance in form of check or money order. If letter contains cash or unused U. S. Postage Stamps, register it.)

These Books are Authentic For All Short Wave Work and LOW in Price

COUPON TODAY!

Please mention SHORT WAVE CRAFT when writing advertisers

Announcing an Important Development..

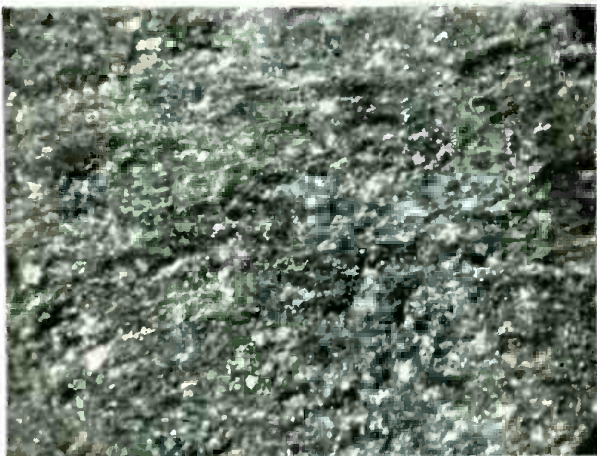

Unretouched photo of Improved Lynch Resistor, taken under 80-power microscope. Note the uniformity which gives greater current-carrying capacity—freedom from heat . . . noise . . . change!

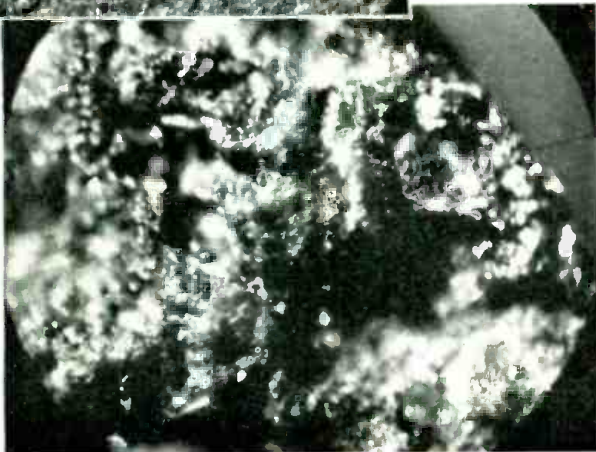

Ordinary resistor under 80-power microscope (unretouched photo). Note rough surface which causes excessive heating;—gradual change in resistance.

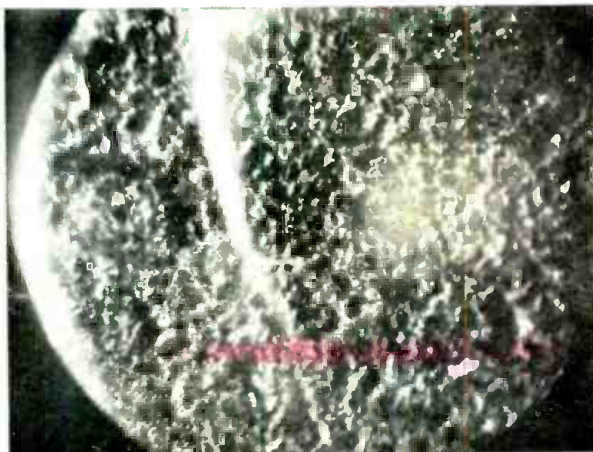

Another ordinary resistor under 40-power microscope (unretouched photo). Lower current-carrying capacity is due to many voids . . . in such a porous mass, contact is point contact only.

The Improved **LYNCH** RESISTOR

The Most Important Advance in Resistors in More Than 10 Years

AFTER more than five years of exhaustive laboratory work and many months of proving in actual service in the field, we are pleased to present a resistor with marked advantages . . . and, at no advance in prices.

Born at dazzling yellow heat, this new ceramic composition possesses the rugged dependability of Gibraltar. Extruded to exacting specification, its uniform texture ensures far greater current-carry-

ing capacity and permanent, noiseless accuracy. Absolutely guaranteed against open-circuiting or change in resistance value. . . . Moisture-repellent!

We invite you to demonstrate for yourself the great superiority of these Triple-tested Resistors. Connect them into circuit, overload them heavily, as we have done for hours, days, weeks! Then make your own measurements for accuracy; noiselessness. If, after your own tests you are dissatisfied, return the resistors to your jobber, or to us and your money will be cheerfully refunded.

Ask your jobber also for our new low prices on Lynch "Bluejackets" and "Selectohms"—the wirewound resistors with a reputation.



*The Gold Standard
of Resistors*



LYNCH MANUFACTURING CO., INC., 405 Lexington Avenue, New York, N.Y.

R. A. Sayres, Pres.

C. G. Culin, Vice Pres.

L. R. Beardslee, Sec.-Treas.

Laboratory and Factory, Cranford, N.J.

SAVE **50%** by BUYING YOUR RADIO *Direct from* **MIDWEST LABORATORIES**

Thrill to *Guaranteed World-Wide* **HIGH FIDELITY** Performance with This
Amazing New **1935-36 MIDWEST SUPER Deluxe 16-TUBE ALL-WAVE Radio!**
 (ALL FIVE WAVE BANDS)



**ONLY RADIO COVERING
 9 TO 2400 METERS
 12,000 MILE TUNING RANGE**

**WORLD'S GREATEST
 RADIO VALUE**

\$57⁵⁰ with New
Deluxe Auditorium-Type
SPEAKER

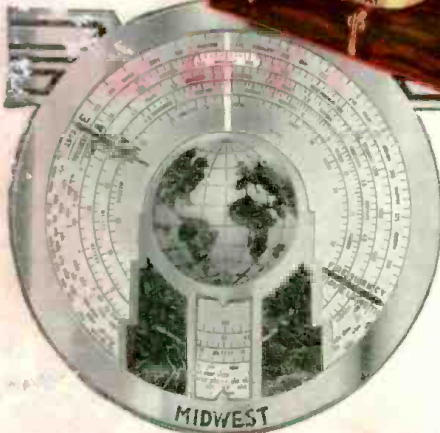

Only Midwest Gives You Multi-Function Dial

This dial was designed in keeping with the trend of the times, yet is not an airplane dial! It is a many-purpose dial that performs many functions. Now, Midwest guarantees that inexperienced persons can secure good foreign reception. Send for FREE actual rotating dial which shows these outstanding advantages:

1. Dial and illuminated;
2. Smooth-Acting Tuning;
3. Station Group Locator;
4. Simplified Tuning Guide Lights;
5. Automatic Select-O-Band Indicator;
6. Illuminated Pointer Indicator;
7. Silent Shadow Tuning—Improvement on Meter Tuning;
8. Centralized Tuning.

New Style Consoles

The Midwest 36-page catalog pictures a complete line of beautiful, artistic de luxe console and chassis in four colors. Write for new FREE catalog today!

Midwest long-range radios are priced as **\$27⁵⁰** low as...



30 Days FREE Trial!

BEFORE you buy any radio write for the new **FREE** 1935-36 Midwest "Fifteenth Anniversary" catalog and see for yourself the many reasons why 110,000 satisfied customers bought their radios direct from the Midwest Laboratories and saved from 1/3 to 1/2. Why pay more than the direct-to-you laboratory price? You, too, can make a positive saving of from 30% to 50% by buying this more economical way. Learn why Midwest outperforms sets costing up to \$200.00 and more. Never before so much radio for so little money! Midwest gives you triple protection with: **One-Year Guarantee, Foreign Reception Guarantee, Money-Back Guarantee.**

50 ADVANCED 1935 FEATURES

Many exclusive features include: Micro-Tenuator... Fidel-A-Stat... Separate Audio Generator... Ceramic Coil Forms, etc. Only Midwest covers a tuning range of 9 to 2400 meters (33 Megacycles to 125 KC)—enabling you to easily and successfully tune in even low-powered foreign stations up to 12,000 miles away with crystal-clear, loud-speaker reception.

All 5 Wave Bands enable you to enjoy today's finest High Fidelity American programs. In addition, you get Canadian, police, amateur, commercial, airplane and ship broadcasts and derive new delight and new excitement from un-

equalled world-wide broadcasts... England, France, Germany, Spain, Italy, Russia, Australia, etc. Send today for money-saving facts!

SENSATIONAL HIGH FIDELITY RECEPTION

This bigger, better, more powerful, clearer-toned, super selective, 16-tube radio gives you absolute realism—assures you of life-like, crystal-clear tone—unlike anything you have ever experienced before. You will hear one more octave—overtone—that cannot be brought in with ordinary radios. Now, hear every instrument, every voice, every shade and inflection of speech.



Take advantage of the amazing 30-day **FREE** trial offer. Send for **FREE** catalog.

TERMS as low as \$5⁰⁰ DOWN

Listens to World-Wide Reception

Vineland, Nova Scotia, Can.
 —I have received many foreign stations including CBE, London; EAQ, Madrid. A friend, head of a radio department in a store, said he would rather buy a Midwest than the make he sells. Charles R. Ingraham.



Peruvian Praises Foreign Reception

Safford, Arizona
 It's a real thrill to listen to my Midwest, to hear a voice from a far off land say: "This is the voice of the Pacific, VK2ME, in Sydney, Australia," or, "We take you now to Westminster Abbey,"... etc. Franklin H. John, P. O. Box 241.



DEAL DIRECT WITH LABORATORIES

Increasing costs are sure to result in higher radio prices soon. Buy before the big advance...NOW...while you can take advantage of Midwest's sensational values...no middlemen's profits to pay. You can order your 1935-36 High Fidelity radio from new Midwest catalog with as much certainty of satisfaction as if you were to select it in our great radio laboratories. You save 30% to 50% when you buy this popular way...you get 30 days **FREE** trial, as little as **\$5.00 down** puts a Midwest radio in your home. Satisfaction guaranteed or money back. Write for new **FREE** catalog today.

SAVE UP TO 50%

MAIL COUPON TODAY!

FOR AMAZING 30-DAY FREE TRIAL OFFER AND NEW 1935 CATALOG

MIDWEST RADIO CORP., Dept. 921, Cincinnati, Ohio.
 Without obligation on my part send me your new **FREE** 1935-36 catalog, **FREE** Miniature Dial, and complete details of your liberal 30-day **FREE** trial offer. This is **NOT** an order.

User-Agents Make Easy Extra Money Check Here for Details

Name.....
 Address.....
 Town..... State.....

Check here if interested in a battery radio.

MIDWEST RADIO CORP.
 DEPT. 921 — CINCINNATI, OHIO, U. S. A.
 Established 1920 Cable Address Miraco. All Codes